

ENERVEX

POWERSTACK VENTING SYSTEM

Models EPSC+

010.8030.1023 10.23

Installation & Operating Manual

Sizes 4–14" (100–350mm)

Special Gas Vent System for Category II, III and IV Appliances

This installation manual will enable you to obtain a safe, efficient and dependable installation of this vent system. Please read and understand these instructions before beginning your installation.

Do not alter or modify the components of this chimney system under any circumstances. Any modification or alteration of the vent system or approved accessories, including but not limited to the appliance it is connected to, may void the warranty, listings and approvals of this system and could result in an unsafe and potentially dangerous installation.

1. Examine all components for possible shipping damage prior to installation.
2. Proper joint assembly is essential for a safe installation. Follow these instructions exactly as written. Check secureness of joints upon completion of assembly.
3. This venting system must be free to expand and contract. This venting system must be supported in accordance with these instructions.
4. Check for unrestricted vent movements through walls, ceilings, and roof penetrations.
5. Different manufacturers have different joint systems and adhesives. Do not mix pipe, fittings, or joining methods from different manufacturers.



WARNINGS

FAILURE TO FOLLOW THESE INSTALLATION INSTRUCTIONS COULD CAUSE FIRE, CARBON MONOXIDE POISONING, OR DEATH. IF YOU ARE UNSURE OF INSTALLATION REQUIREMENTS, CALL THE PHONE NUMBER LISTED ON THE BACK OF THESE INSTRUCTIONS.

A MAJOR CAUSE OF CHIMNEY RELATED FIRE IS FAILURE TO MAINTAIN REQUIRED CLEARANCES (AIR SPACES) TO COMBUSTIBLE MATERIALS. IT IS OF UTMOST IMPORTANCE THAT THIS VENT SYSTEM BE INSTALLED ONLY IN ACCORDANCE WITH THESE INSTRUCTIONS



UL File MH64314

READ AND SAVE THESE INSTRUCTIONS!

Manufactured by ENERVEX Inc.

ENERVEX Inc.
1685 Bluegrass Lakes
Parkway
Alpharetta, GA 30004
USA

P: 770.587.3238
F: 770.587.4731
T: 800.255.2923
info@enervex.com
www.enervex.com

ENERVEX®
VENTING DESIGN SOLUTIONS 



This symbol shows that ENERVEX PowerStack EPSC+ venting systems are listed in the US and certified for Canada under Underwriters Laboratories Inc. file no. MH64314.

IMPORTANT: READ THESE INSTRUCTIONS CAREFULLY PRIOR TO INSTALLATION.

WARNING

Failure to follow these installation instructions could cause FIRE, CARBON MONOXIDE POISONING, and/or DEATH. If you are unsure of installation requirements, contact ENERVEX.

The following caution notice is used throughout this manual to bring attention to the presence of potential hazards, or to important information concerning the product.



Caution: Indicates an imminent hazardous situation which, if not avoided, may result in personal injury or property damage.

How to use this manual

This installation manual does not contain any system design documentation. System design documentation is available from any authorized ENERVEX representative. Accessories, fans, and variable frequency drives are not covered in this manual. Please refer to those components' individual manuals.

Content

1. GENERAL INFORMATION	4	6. STRUCTURAL SUPPORT AND GUIDE COMPONENTS	21
1.1 Introduction	4	6.1 Support Plate Assembly	21
1.2 Features	4	6.2 Horizontal Support	21
1.3 System Design And Calculations	4	6.3 Wall Support.....	22
1.4 Underwriters Laboratories Listings.....	4	6.4 Floor Guide.....	22
1.5 General Installation Requirements.....	4	6.5 Wall Guide.....	22
1.6 Termination.....	5	6.6 Full Ring / Half Ring	23
1.7 Surroundings / Enclosure	5	6.7 Guide Band	23
1.8 Clearances	5	6.8 Guy Section Assembly.....	23
1.9 Pipe Weight	5	6.9 Centering Band	24
1.10 Pipe Joint Assembly	6	6.10 Supporting Tees And Elbows.....	24
1.11 Support Methods	6	7. ROOF PENETRATIONS, THIMBLES AND FLASHING	25
1.12 Vertical Support.....	6	7.1 Unvented Insulated Roof Assembly	25
1.13 Horizontal / Vertical Guide Spacing.....	6	7.2 Wall Penetration.....	26
1.14 Horizontal Support Spacing.....	6	7.3 Flashings And Storm Collars.....	26
1.15 Vertical Installation Requirements.....	6	8. MISC. COMPONENTS	27
1.16 Wall Penetration.....	7	8.1 Transitions to EPS, EPSA, EPS1, EPS2 and EPS4 with Flanged ...	27
1.17 Condensation Drains	7	Connections	27
1.18 Vent Joint Assembly	8	8.2 Other Transitions	27
1.19 Locking Band Assembly	9	9. WARRANTY	31
1.20 Replacing a Seal.....	9	9.1 Standard 1-Year Warranty	31
2. CONNECTION AND ADAPTERS	10	9.2 Extended 15-Year Warranty	31
2.1 Universal Boiler Kit Adapter	10		
2.2 Flange Adapter	10		
2.3 Appliance Adapters	10		
3. STRAIGHT LENGTHS	11		
3.1 Pipe Lengths	11		
3.2 Nozzle Section	11		
3.3 Drain Section.....	11		
3.4 Adjustable Length.....	12		
3.5 HD Locking Band Assembly	16		
4. TEES, ELBOWS, INCREASERS, OFFSETS AND MANIFOLD, DRAINS	17		
4.1 45° Lateral Tee	18		
4.2 90° And 87° Tee	18		
4.3 3°, 6°, 15°, 30°, 42° 45°, 87°, 90° Elbows.....	18		
4.4 Tee Cap.....	19		
4.5 Drain Tee Cap.....	19		
4.6 Tapered Increaser/Reducer.....	19		
4.7 Eccentric Increaser/Reducer.....	19		
5. TERMINATIONS	19		
5.1 General.....	19		
5.2 Vent Cap	19		
5.3 Sidewall Termination	19		
5.4 Miter Cut Section.....	19		
5.5 Fan Plate Adapter.....	20		
5.6 Fan Adapter Termination.....	20		

1. GENERAL INFORMATION

1.1 INTRODUCTION

These instructions comprise both general guidelines and special requirements for all parts in the product line. Before specifying a design or beginning an installation please carefully review these instructions.

CONTACT LOCAL BUILDING OR FIRE OFFICIALS ABOUT RESTRICTIONS AND INSTALLATION INSPECTION IN YOUR AREA.

1.2 FEATURES

PowerStack EPSC+ is made for residential, commercial and industrial applications. It is a factory made modular stainless steel venting system designed for quick assembly. All parts have a male and a female end with an Elastomer Triple Lip Seal.

PowerStack EPSC+ is offered in a double wall version and is available in internal diameters ranging from 4" (100mm) to 14" (350mm). The fully welded liner is manufactured from a special corrosion resistant 316L PCM (Purified Chromium and Molybdenum).

A pressure capability of up to 15"Wg (3,745Pa) and condensate containment is achieved by using a Elastomer Triple Lip Seal as part of a simple push-fit joint design that is held in place with a lever type locking band.

All Powerstack models (EPS, EPSA, EPSC, EPS1, EPS2 EPSC+ and EPS4) may be intermixed in the same venting system, provided the proper associated airspace clearances-to-combustibles are maintained.

PowerStack EPSC+ is suitable for negative, neutral or positive pressure applications and intended for use in a variety of applications including, but not limited to, Special Gas Vent for Category II, III and IV.

1.3 SYSTEM DESIGN AND CALCULATIONS

Complete system sizing and capacity information may be obtained from the "Chimney, Gas Vent, and Fireplace Systems" chapter of the ASHRAE Handbook, from the ENERVEX "Chimney and Exhaust System Design Handbook", or by contacting ENERVEX Technical Support. In spite of any sizing guidelines, when sizing venting systems, it is most important that the appliance manufacturer's installation instructions be followed.

Failure to follow these instructions may result in inadequate vent system performance and/or a violation of the equipment manufacturer's installation requirements. Proper operation of the venting system and appliance is dependent on the use of all parts specified by the manufacturer for use in the particular installation. The performance of the system may be affected if the proper assembly of all required parts is not accomplished.

1.4 UNDERWRITERS LABORATORIES LISTINGS

The ENERVEX PowerStack EPSC+ venting system is

Listed by Underwriters Laboratories, Inc. (UL) under UL File MH64314.

EPSC+ is listed to UL 1738 Venting Systems for Gas-Burning Appliances, Categories II, III, and IV (480°F Vent Listing) / ULC S-636 Standard for Type BH Gas Venting Systems (480°F Venting Listing)

Under this category, EPSC+ in diameters 4" to 14" has been determined suitable for venting of flue gases at a temperature up to 480°F (249°C) from gas fired appliances. See Section 1.10 Clearances" for specific details.

1.5 GENERAL INSTALLATION REQUIREMENTS

When venting Category II, III, or IV appliances or vented appliances, PowerStack must be used for the entire length of the system. Do not mix pipe, fittings, or joining methods from different manufacturers

Refer to the gas appliances manufacturer's instructions to determine venting requirements and limitations with respect to installation and use of the appliance. It is the responsibility of the installer to contact local building and fire officials concerning any installation restrictions and/or inspection requirements that may apply.

Permits may be required before starting an installation.

If required by the appliance manufacturer, a condensate drain fitting must be located as close as possible to the appliance flue outlet. Depending on the arrangement of the vent, more than one drain may be required.

Only one Category II, III, IV appliance shall be connected into a venting system, unless the appliance manufacturer specifically approves a multiple venting system. Cat. II, III or IV appliances SHALL NOT be common vented with Cat. I, natural draft appliances. This limitation can be ignored if an engineering analysis demonstrates normal and safe operation of appliances.

PowerStack shall not be routed into, through, or within any vent, such as an existing masonry or factory-built chimney, that is connected to another appliance.

Any horizontally installed portion of the venting system shall have a slope (upwards for Category II, III, or IV appliances or downwards for Category III or IV appliances) not less than 1/4 inch (6.4 mm) every 12 inches (305 mm) to prevent collection of condensate at any location in the assembly; and means shall be provided for draining the condensate.

Due to possible ice build up and blockage, it is required that the proper sloping be employed when the vent is installed in a horizontal installation. Refer to the appliance manufacturer's installation instructions for further details regarding the installation of the condensate drain fittings;

A venting system that is mounted at the exterior shall be enclosed below the roof line to limit condensation and protect against mechanical damage.

After installation, the joints and seams shall be checked for gas tightness when using the venting system with a Category III or IV appliance.

1.6 TERMINATION

For EPSC+ systems used as Special Gas Vents, the systems shall terminate above the roof level in accordance with the following requirements:

- Five feet above the roof level or any adjacent flat roof, wall parapet or air intakes, and/or in accordance with the following NFPA 211 requirements.
- Where vent terminates at less than 10 feet from any adjacent ridge, wall or parapet, the vent shall terminate at minimum 3 feet above the ridge, wall or parapet.
- Where vent terminates at more than 10 feet from ridge, wall or parapet, a minimum height of 2 feet shall be required above the ridge wall or parapet.

Vent systems that exit the structure through a sidewall or the like shall terminate in accordance with the following requirements:

- Not less than 12 inches above the ground.
- Located above the snow line in geographical areas where snow accumulates.
- Not located in traffic areas, such as walkways, unless the venting system is at least 7 feet (2.13m) above the ground.

The installation of the venting system relative to appliances that incorporate combustion air inlet systems shall have a venting system that terminates:

- 6 feet (1.8 m) or more from the combustion air intake of any appliance.
- More than 3 feet (0.91 m) from any other building opening, gas utility meter, service regulator, and the like.
- Less distance if specified in the appliance's instructions.

The venting system shall not be routed into, through, or within any other vent such as an existing masonry or factory built chimney flue (exception: a masonry chimney flue may be used to route the venting system if no other appliance is vented into the same masonry chimney flue and the installation instructions specify such restrictions).

For EPSC+ venting systems used with Category II and III appliances, the vent must terminate at least 3 feet above the highest point where it passes through a roof of a building and a minimum of 2 feet higher than any part of the building with a horizontal distance of 10 feet. There are exceptions to these requirements when a mechanical draft system is used and some listed appliances have other requirements, so it is recommended to consult with the authority having jurisdiction for actual requirements.

1.7 SURROUNDINGS / ENCLOSURE

PowerStack vents are primarily intended to be used in fire resistive, noncombustible surroundings or installed unenclosed.

Where the vent extends through any zone of a building outside the area in which the heating appliance connected to it is located, it shall be provided with an enclosure having a fire resistance equal to or greater than the fire rating of the floor, ceiling, wall or roof assemblies through which it passes.

All PowerStack EPSC+ models may penetrate a combustible roof using the Insulated Roof Assembly. This is the only part intended for use with combustible construction. All other parts, such as Plate and Wall Supports, and Floor and Wall Guides, are for attachment to non-combustible construction.

Where, according to local code, no chase enclosure is necessary, Model EPSC+ may be placed adjacent to walls of combustible construction at the minimum clearance specified on each pipe section and in the individual Listing; see CLEARANCES section and Table 1-1. Contact local building or fire officials about restrictions and installation inspection requirements in your area.

Do not place any form of insulation in the required clearance spaces listed in Table 1-1.

1.8 CLEARANCES

The EPSC+ must meet the clearance requirements shown in Table 1-1.

SIZE INCH (MM)	CLEARANCE TO COMBUSTIBLES INCH (MM)	
	VERTICAL ENCLOSED/ UNENCLOSED	HORIZONTAL UNENCLOSED
4 (100)	1 (25)	1 (25)
5 (130)	1 (25)	1 (25)
6 (150)	1 (25)	1 (25)
7 (180)	1 (25)	1 (25)
8 (200)	1 (25)	2 (51)
10 (250)	1 (25)	2 (51)
12 (300)	1 (25)	2 (51)
14 (350)	1 (25)	3 (76)

Table 1-1: Clearance to Combustibles - EPSC+ Special Gas Vent

See also section 1.7 Surroundings / Enclosure. All applicable NFPA 211 requirements must be followed.

1.9 PIPE WEIGHT

Pipe weight is given in lbs/ft (kg/m) for each diameter. It is important to know the weight of the chimney section for chimney support and guiding.

SIZE Inch (mm)	PIPE WEIGHT lbs/ft (kg/m)
	EPSC+
4 (100)	2.96 (4.4)
5 (130)	3.63 (5.4)
6 (150)	4.05 (6)
7 (180)	4.74 (7.1)
8 (200)	5.20 (7.7)
10 (250)	6.35 (9.4)
12 (300)	7.47 (11.1)
14 (350)	8.52 (12.7)

Table 1-2: Pipe Weight - EPSC+ Special Gas Vent

1.10 PIPE JOINT ASSEMBLY

PowerStack components have a male-to-female joint system with an integrated Elastomer Triple Lip Seal. The installation orientation is inner female end or outer male end points downstream. Flow direction is indicated by an arrow on the product label.

When assembling two parts together, the joint will overlap 1.96" (50mm). Effective length is nominal length minus 1.96" (50mm).

STRAIGHT SECTIONS	EFFECTIVE LENGTH in (mm)
	EPSC+
L50	44.72 (1136)
L40	38.35 (974)
L30	28.50 (724)
L20	18.66 (474)
L10	8.82 (224)
L4	3.86 (98)

Table 1-3: Effective Lengths

1.11 SUPPORT METHODS

Several support and guiding methods are used to anchor the vent against upward, downward and angular displacement. The supports and guides used with thermal expansion devices prevent bending stresses on the vent elbows and joints.

1.12 VERTICAL SUPPORT

The maximum height/length limits for each support method are shown in Tables 1-4, 1-5 and 1-6.

SIZE Inch (mm)	MAX. HEIGHT ABOVE SUPPORT PLATE ft (m)
	EPSC+
4 (100)	95 (29)
5 (130)	77 (23)
6 (150)	69 (21)
7 (180)	59 (18)
8 (200)	54 (16)
10 (250)	44 (13)
12 (300)	37 (11)
14 (350)	33 (10)

Table 1-4: Support Above Base Plate

Note 1- values in table 1-4 are for connecting to non-combustible wall and have not been confirmed by UL LLC.

Note 2- maximum distance between supports confirmed by UL for combustible walls is 30ft.

SIZE Inch (mm)	MAX. FREESTANDING ABOVE ROOF SUPPORT ft (m)
	EPSC+
4-14 (100-350)	5 (1.5)

Table 1-5: Freestanding Above Roof Support

Proper guying and bracing is essential for part of the vent that extends above the roof or parapet wall. The vent at this point is subject to wind conditions and needs special attention for proper stabilization.

If the vent above the roof does not exceed dimensions in Table 1-5, no special guying or bracing is required. However, to protect the flashing from lateral movement, a guide must be installed at the roof level. The vertical freestanding height above the roof or top guide is limited due to wind considerations.

For vent height above the roof that needs guying or bracing, a support, a small length and a expansion length must be installed near the roof level to absorb the thermal expansion and minimize this effect on the guy wire or brace.

When using guy wire, the cable must be slightly slack or loose to allow thermal expansion.

1.13 HORIZONTAL/VERTICAL GUIDE SPACING

Wall guides are used in vertical installations to maintain proper alignment of the system and are for lateral support for wind loads.

SIZE Inch (mm)	MAX. HORIZONTAL GUIDE SPACING
	ft (m) EPSC+
4-14 (100-350)	6 (1.8)

Table 1-7: Horizontal Guide Spacing

SIZE Inch (mm)	MAX. VERTICAL GUIDE SPACING
	ft (m) EPSC+
4-14 (100-350)	8 (2.4)

Table 1-8: Vertical Guide Spacing

1.14 HORIZONTAL SUPPORT SPACING

Horizontal installations or horizontal portions of vertical installations are supported by use of Half or Full Rings that are installed using minimum 5/16" threaded rod or structural steel (provided by others). See Table 1-7 for maximum spacing between horizontal supports.

Plate Supports are also used to support and stabilize the system at changes in direction and when using expansion sections.

1.15 VERTICAL INSTALLATION REQUIREMENTS

Vent systems without provisions for draining rain water must use a Rain Cap.

Terminations or approved mechanical draft systems specified or provided by the appliance manufacturer are permitted.

The total continuous distance of the vent system from the appliance flue collar to the termination shall not exceed that specified in the appliance manufacturer's installation instructions.

In general, systems installed in cold climates perform best, and condensation is reduced, when the system is fully enclosed by some part of the building structure or by using insulated EPS1 venting system.

Condensate drains should not be installed on the exterior of the building. Doing so may result in dangerous icy conditions on surfaces near the drain and may cause damage to the vent system and/or the building exterior, or property damage due to any formation of ice.

Vertical supports are required after every transition to vertical. Vertical supports are also required after every offset elbow.

Unless EPSC+ is installed in a fire rated shaft, a roof thimble and support is required when penetrating fire rated floors, walls or ceilings.

1.16 WALL PENETRATION

This Wall Penetration assembly is primarily used for wall penetration allowing a section to pass through a wall made of combustible material. It is used to maintain a minimum clearance between the combustible wall material and the vent section passing through the wall.

1.17 CONDENSATION DRAINS

When an internal condensate drain is NOT part of the appliance, a Drain length or a Tee with a Drain Tee Cap is strongly recommended.

Install this drain as close as possible to the appliance flue collar. A condensate drain is also required for every 30 feet of horizontal vent and at the bottom of a vertical stack.

Use the Drain length for a straight horizontal run. Rotate the fitting so that the drain tube is as vertical as possible.

Use a Tee at a transition from horizontal to vertical, and attach the Drain Tee Cap to the appropriate branch of the tee.

Flue gas condensate can have a low (3 to 5) PH level, follow all local and national codes and regulations for the draining of acidic condensate.

1.18 VENT JOINT ASSEMBLY

All EPSC+ components feature a simple push-fit joint design, allowing ease and speed of installation, while maintaining a secure and pressure tight joint. To assemble the joint, simply follow the steps below.

1. EPSC+ is always installed with the female spigot of the liner facing towards the termination and the male end of inner liner facing towards the appliance. The product label includes an arrow pointing away from the appliance. See Fig. 1-1
2. Having checked the correct orientation of the product, clean both the male and female ends with a suitable cloth to ensure they are free from dirt and grit.
3. Apply a 1/4" bead amount of RTV Silicone around the outer circumference of the male end. Do the same around the inner circumference of the Elastomer Seal, while also checking the seal for any potential signs of damage. See Fig. 1-2. Repeat these steps for the outer jacket.
4. After applying RTV Silicone, align the male end into the female and push the joint together using a slight twisting action.
5. With the joint assembled, locate the Locking Band around the joint as detailed in Fig. 1-3. The Locking Band must be installed so that the toggle is only closed from left to right.

NOTE: Hi temp RTV silicone is required at each joint and is supplied by Enervex Inc.

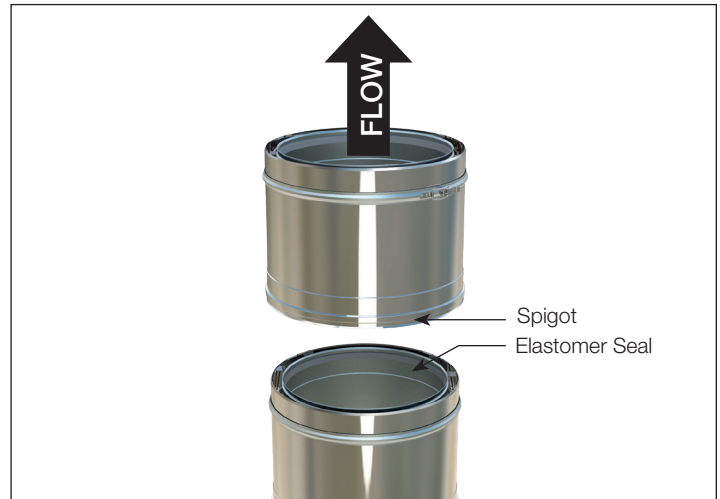

Fig 1-1: Flow direction

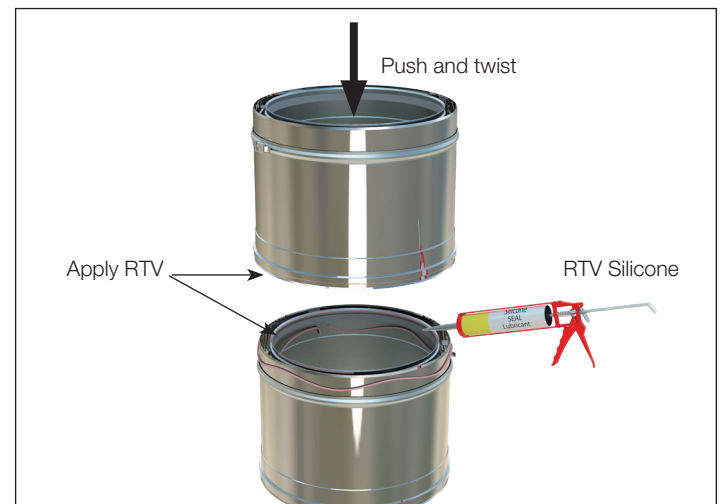

Fig 1-2: Applying RTV Silicone

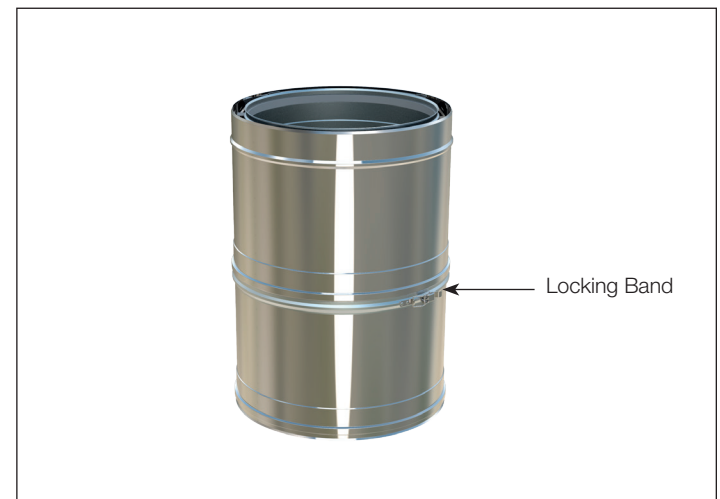

Fig 1-3: Securing joint with locking band



Do not secure screws into the vent. The locking band is the only thing needed for proper assembly.

Risk of injury. Sheet metal parts may be sharp. Always wear gloves and appropriate eye, foot, and other protection when handling these products.

1.19 LOCKING BAND ASSEMBLY

The locking band has a unique profile and must be installed using the correct orientation. It MUST be located so the snap lock is only closed from left to right.

1. Attach the drawer to the latch See Fig. 1-4
2. Pull the drawer handle to the left to lock in place. See Fig. 1-5.

1.20 REPLACING A SEAL

The Elastomer Seal offers many years of troublefree service. However, improper installation or assembly of the vent can potentially damage the seal which can cause leakage.

Follow these steps to replace a seal:

1. Remove the old seal and fully clean the location groove for residue.
2. Apply a thin bead of silicone sealant around the internal circumference of the seal groove making sure there is enough to bond the seal to the vent.
3. Position the new seal in the groove and make sure the vanes of the seal are facing down toward the male end.
4. Once in place, make sure the seal is firmly located back against the rear end of the seal groove. Make sure there is no silicone residue on the vanes which can impact the pressure and condensate resistance of the joint. Allow 24 hours to cure before installing.



Fig 1-4: Snap Lock - Open



Fig 1-5: Snap Lock - Closed

2. CONNECTION AND ADAPTERS

2.1 UNIVERSAL BOILER ADAPTER

A Universal Boiler Kit Adapter is designed to connect a chimney to a boiler or other appliance having a flanged outlet with a 4, 6, 8 or 12 bolt hole pattern. The Boiler Adapter is a flat 1/8" thick steel ring supplied with 24 holes. To Install:

1. Use the included graphite gasket to seal the face of the bolt flange to the boiler flange.
2. Align the bolt flange with the appliance's flange and align the bolt slots with bolt holes in the boiler flange.
3. Tighten all nuts and bolts in an alternating pattern until the pipe flange is seated firmly between the boiler and the adapter.

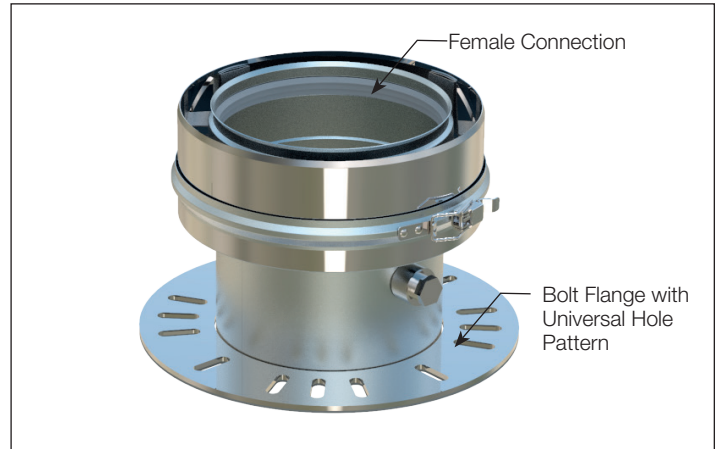

Fig 2-1: Universal Boiler Kit Adapter

2.2 FLANGE ADAPTER - ANSI 125/150

This component is a short liner length with a standard EPSC+ at one end and an ANSI 125/150 bolt flange attached at the other end. Can be connected to another ANSI 125/150 bolt flange whether on a generator, engine, boiler or other appliance.

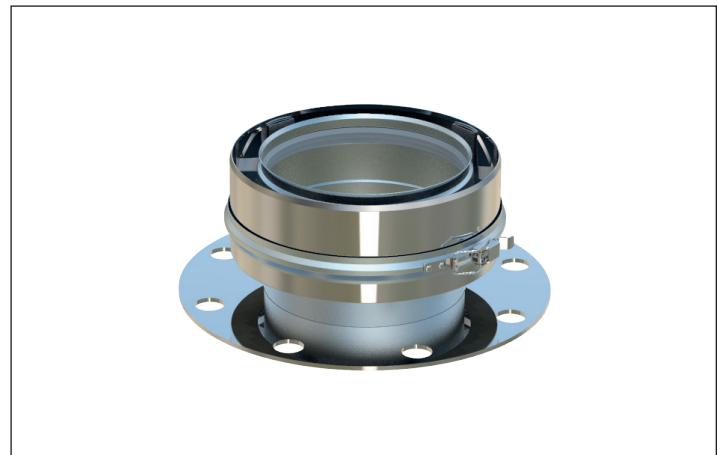

Fig 2-2: Flange Adapter

2.3 APPLIANCE ADAPTERS

ENERVEX supplies adapters for most common appliances.



Fig 2-3: Appliance Adapter

3. STRAIGHT LENGTHS

3.1 PIPE LENGTHS

The PowerStack EPSC+ is available in various standard nominal lengths:

- 6" - Installed length = 4" (98mm)
- 10" - Installed length = 9" (224mm)
- 20" - Installed length = 18" (474mm)
- 30" - Installed length = 28.5" (724mm)
- 40" - Installed length = 38" (974mm)
- 50" - Installed length = 44.7" (1136mm)
- Adjustable Length
- Adapter Stub

All standards lengths are available with 2 test ports with 1" NPT stainless steel nipple.



Fig 3-1: Straight Length

3.2 NOZZLE SECTION

The Nozzle Section (See Fig. 3-2) can be positioned so that the nozzle fitting is either on the sides or top of the section. The test ports can be used for installation of pressure sensors.

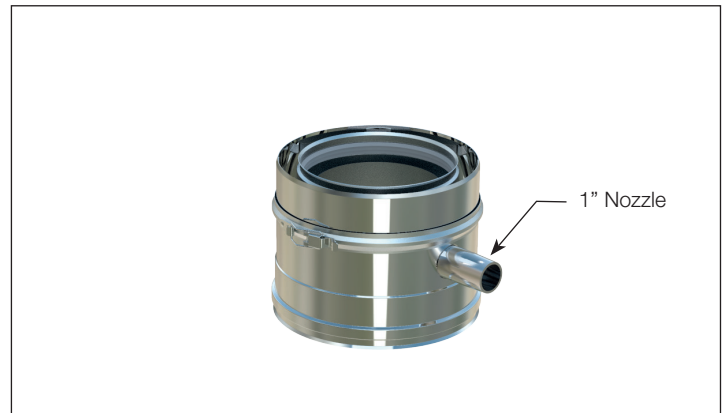

Fig 3-2: Nozzle Section

3.3 DRAIN SECTION

For use with open vent terminations for draining of rain or condensate from inside the vent. Should be located inside the building to protect against freezing. When required, it can also be used as a horizontal drain section installed in the horizontal section of the vent. Includes a Locking Band. The Drain Section incorporates a 1" NPT stainless steel nipple with protective plastic cap.

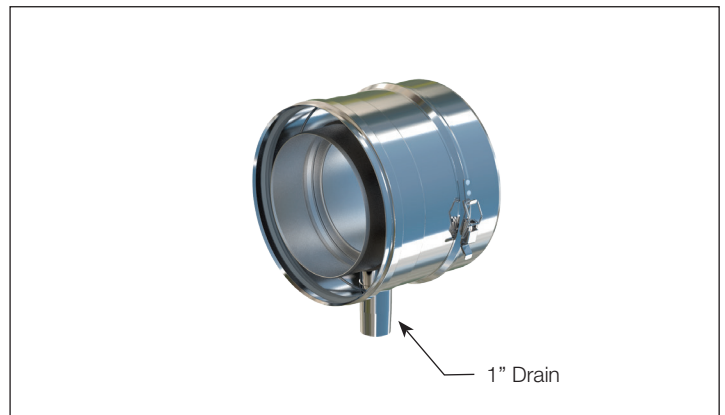

Fig 3-3: Drain Section

3.4 ADJUSTABLE LENGTHS

The Adjustable Length consists of a slip section EPSC+, the lower non-beaded end of which is designed preferably to be located into a standard length and must engage to a depth equivalent to at least half of the diameter of the diameter of the EPSC+ being used,

Table 3-1 below shows the MIN and MAX lengths of the Adjustable Lengths:

SIZE Inch (mm)	MIN/MAX LENGTH in (mm)	
	A Min	A Max
4 (100)	2.48 (63)	12 (305)
5 (125)	2.48 (63)	12 (305)
6 (150)	2.48 (63)	12 (305)
7 (175)	2.48 (63)	12 (305)
8 (200)	2.48 (63)	12 (305)
10 (250)	2.48 (63)	12 (305)
12 (300)	2.48 (63)	12 (305)
14 (350)	2.48 (63)	12 (305)



Fig 3-4: Adjustable Length Assembly Details

Table 3-1: Adjustable Length - Min/Max

Fig. 3-5 shows the joint detail. Locate the seal over the female end of the length before inserting the male end and then pull the seal up so the angled notch on its inside locates over the turned end of the female socket as shown.

The profile of the HD Locking Band means it can only be applied one way. If located incorrectly, the joint will be adequately sealed. See 3.5 for details.

WARNING: The Adjustable Length can only be used when connected to standard lengths. Under no circumstances should they be used directly connected to elbows and Tee's.

Adjustable lengths are not loadbearing and must be supported from above. Always ensure that either a Support Plate or a Wall Support is one straight length above the Adjustable Length to support the vent.

Step 1:

Slide inner slip section into straight section. Insert to max depth.
Slide outer slip section into straight section. Insert to max depth.

NOTE: MAKE SURE ADJUSTABLE SEAL IS INSTALLED ON OUTER SLIP SECTION AT THIS STEP.

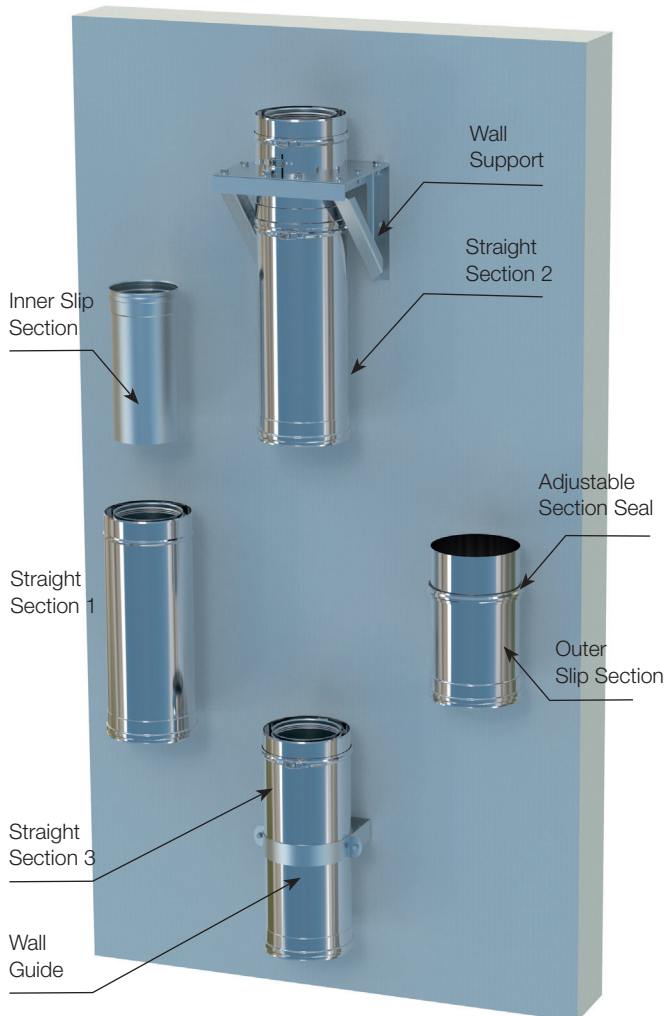
**Step 2:**

Apply 1/4" RTV Beads to Straight Section 3.
Install Straight Section 1W/Inner Slip Section onto Straight Section 3.

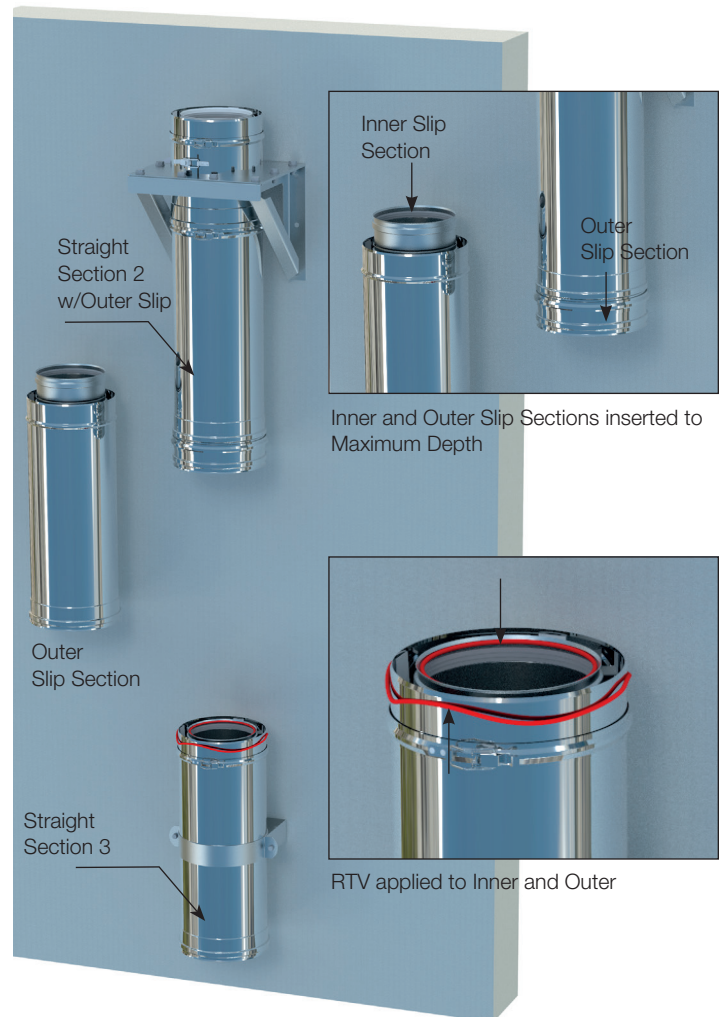

Step 3:

Apply RTV to Inner Slip Section and Slide until it fully seats against Adjacent Inner Male End.



Step 4:

Apply RTV Bead to Adjacent Male Outer End.

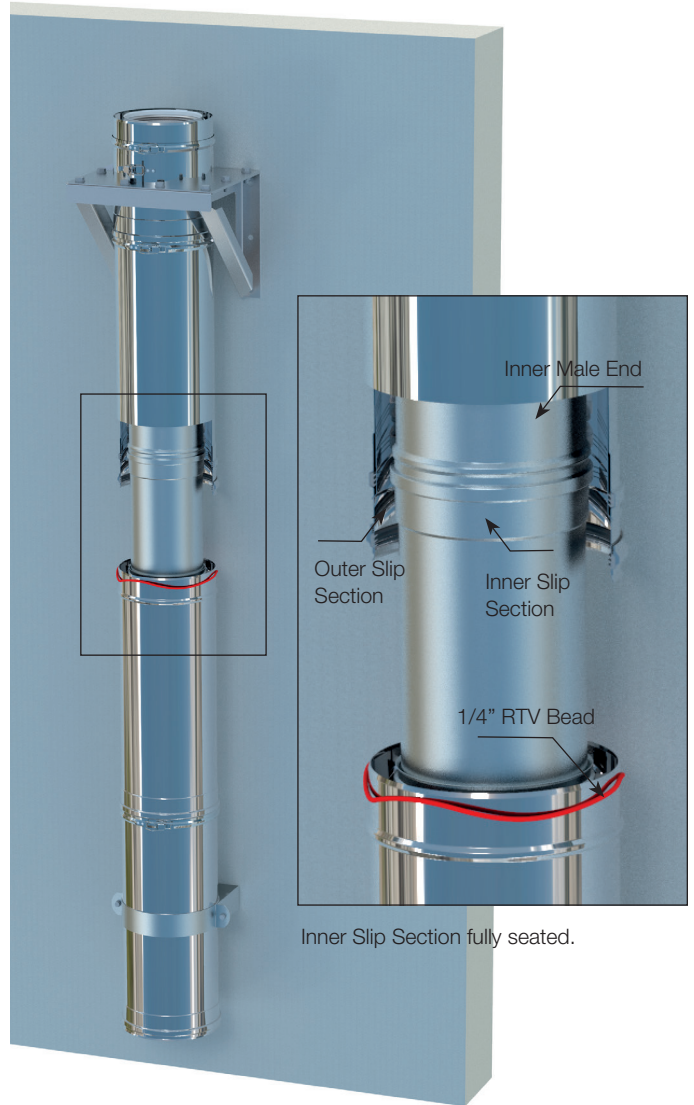

Step 5:

Slide Outer Slip Section until it fully Seats on Adjacent Male Outer end once fully Seated, add Locking Bands.

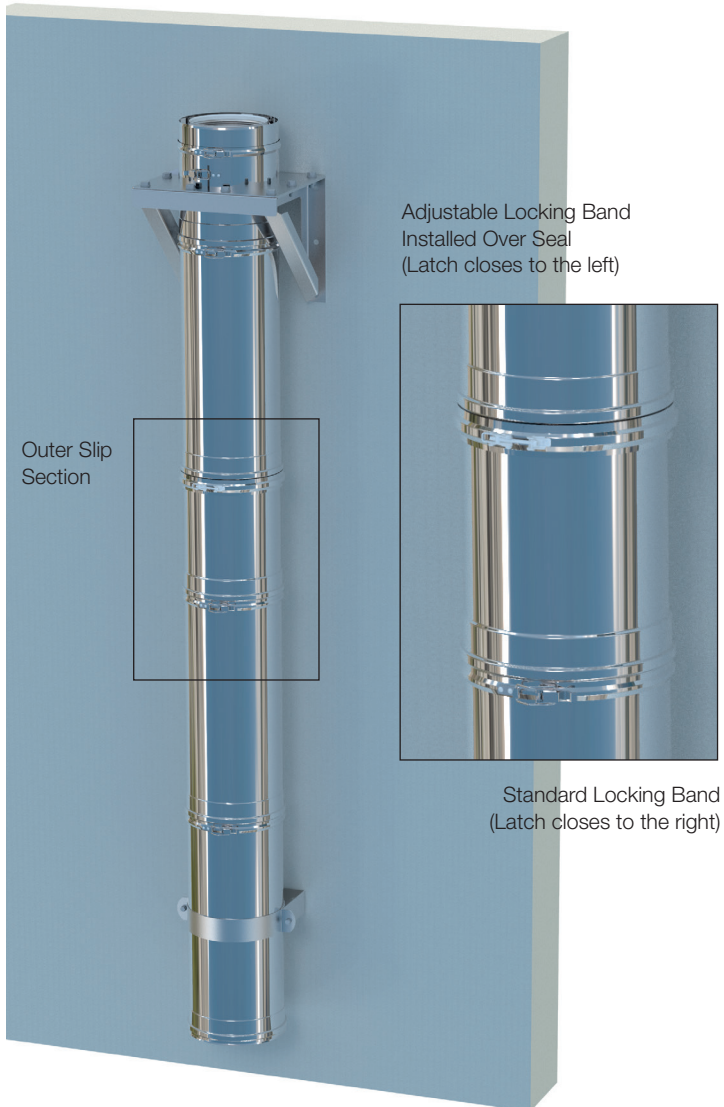

3.5 HD LOCKING BAND ASSEMBLY

The HD Locking Band has a unique profile and must be installed using the correct orientation. It MUST be located so the snap lock is only closed from right to left.

1. Screw toggle on the HD Locking Band should be adjusted so that when the rod end is engaged in the strike, the lever pin is between 5 and 10 deg past the centre line.
See Fig. 3-6
2. Pull the toggle to the left to lock in place.
See Fig. 3-7
3. Tighten the HD Locking Band with the hex key.
See Fig. 3-8



Fig 3-6: Screw toggle



Fig 3-7: Pull toggle to the left

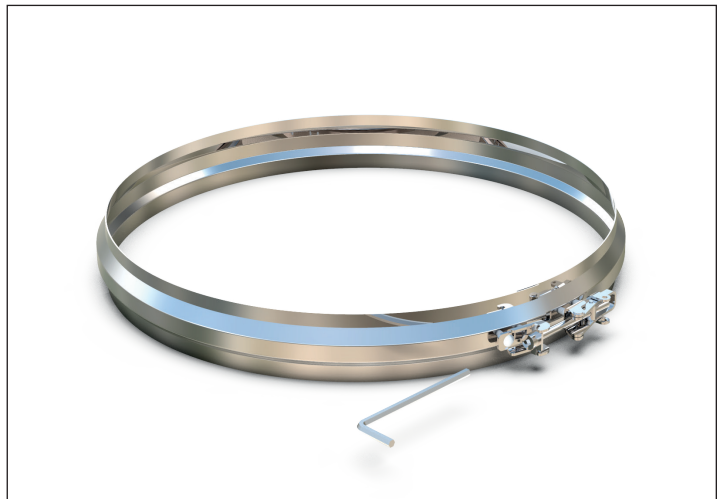

Fig 3-8: Tighten HD Locking Band

4. TEES, ELBOWS, INCREASERS, OFFSETS AND MANIFOLD, DRAINS

4.1 45° LATERAL TEE

Designed to provide connection, a change of direction and cleaning access if required. Can also be used to enable header connections to be made.



Fig 4-1: 45° Lateral Tee

4.2 90° AND 87° TEE

The 90° Tee is designed to provide connection, a change of direction and cleaning access if required. Can also be used in multiples for header configuration. The 87° Tee is used in condensing applications to provide a 3° slope to allow for the back flow of condensation through the system to a suitable drainage component.

Available in equal and reducing Tee versions.



Fig 4-2: 90° Tee

4.3 3°, 6°, 15°, 30°, 42° 45°, 87°, 90° ELBOWS

Elbows are used to change directions. Can be used in singular or in combinations.

Elbows must be protected from thermal expansion and bending forces. They do not bear load.

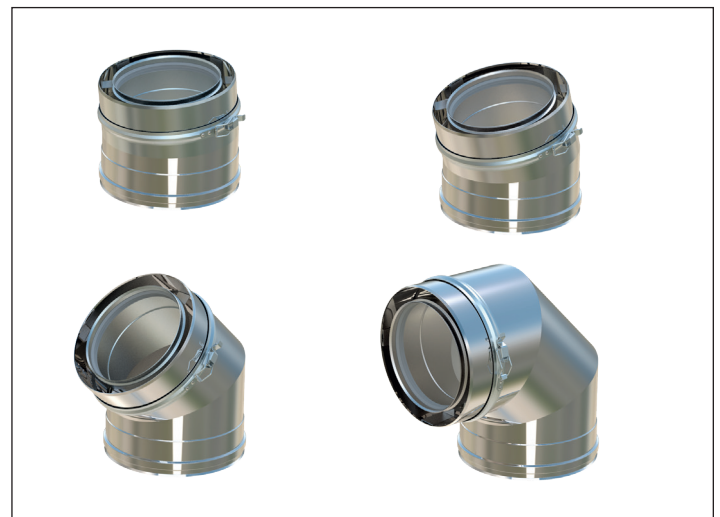

Fig 4-3: Samples of Elbows

4.4 TEE CAP

Used to close off the unused opening of Tees and branched elbows where used for cleaning access.

It can also be used as an end cap in horizontal runs, or as an inspection fitting cover.

4.4-2 DRAIN TEE CAP

The Drain Tee Cap is used as a drain for vertical vents. When not used as a drain the nipple shall be closed off with a pipe cap supplied by the installer. When used as a drain, a trap or a valve should be used in the drain line.

Always connect the drain fitting of the Drain Tee Cap to a suitable drain. This will allow rain entering the vent to wash down, dilute and remove any corrosive combustion condensate.



Fig 4-4: Tee Cap and Drain Tee Cap

4.5 TAPERED INCREASER/REDUCER

Tapered Increases are made with a standard side angle for low pressure losses, and provide an increase of one, or two sizes.

You can tell the difference between an increase and a decrease by the location of the male end (spigot).

Increases have angle from 11.3 to 56 depending on steps. Up to 3 Step increasers available.

Reducers have angle from 11.3 to 44.6. Up to 2 step reducers available.



Fig 4-5: Tapered Increase/Reducer

4.6 ECCENTRIC INCREASER/REDUCER

The Eccentric Increaser and Reducer serve the same purpose as the Increaser and Reducer. They are usually installed in a horizontal part of a vent system, where they allow for a smooth transition at the lowest part of the run. They are used in systems where condensate is present where they allow for easy run off.

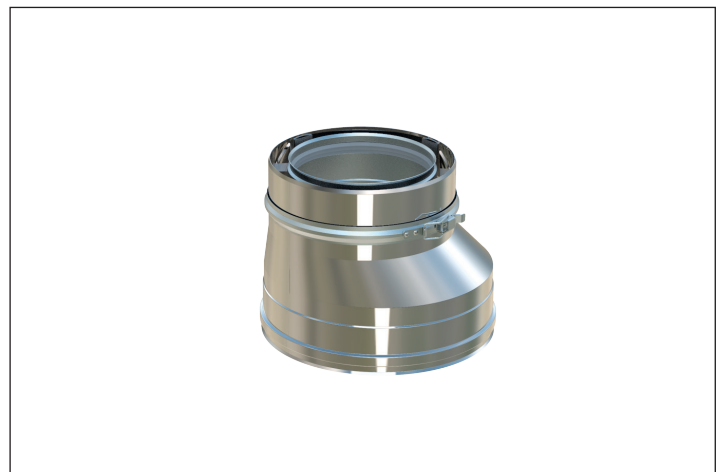

Fig 4-6: Eccentric Increase/Reducer

5. TERMINATIONS

5.1 GENERAL

An upward discharge (such as with an Exit Cone or Open Top) provides the most effective means of dispersing vent gases into the atmosphere and away from immediate surroundings. Such terminations however, will allow entry of rain unless there is upward flow at high velocity. A Vent Cap is only partially effective in excluding rain. Its effectiveness depends on vent gas flow rate, raindrop characteristics and wind velocity.

With all vent terminations, where rain may enter the vent outlet, the following precautions must be taken:

1. All inner joints must be sealed using the appropriate seal or sealant.
2. Install a Vertical Drain Section at least 5 pipe diameters below the vent outlet, but above any Tee or Elbow.
3. If a 90° or 45° Tee is used to catch rain, connect the Tee Cap drain fitting to a suitable drain. Use a trap in the drain if the system is under positive pressure.

Note: The Vertical Drain Section and Drain Tee Cap may both be used.

5.2 VENT CAP

The Vent Cap combines partial protection against rain entry with low exit flow resistance. (Resistance coefficient is roughly 0.05 velocity heads.) It is mounted to the end of a standard pipe section by use of the standard Locking Band.

5.3 SIDEWALL TERMINATION

The Sidewall Termination is used for sidewall vented applications. It incorporates a bird screen/mesh.

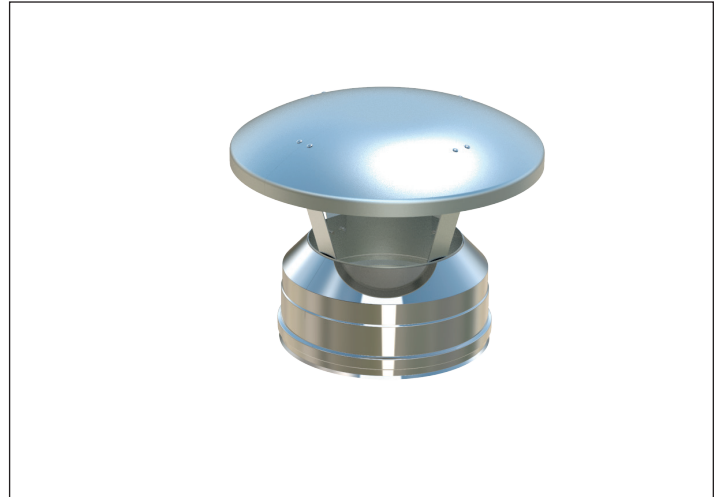

Fig 5-1: Vent Cap

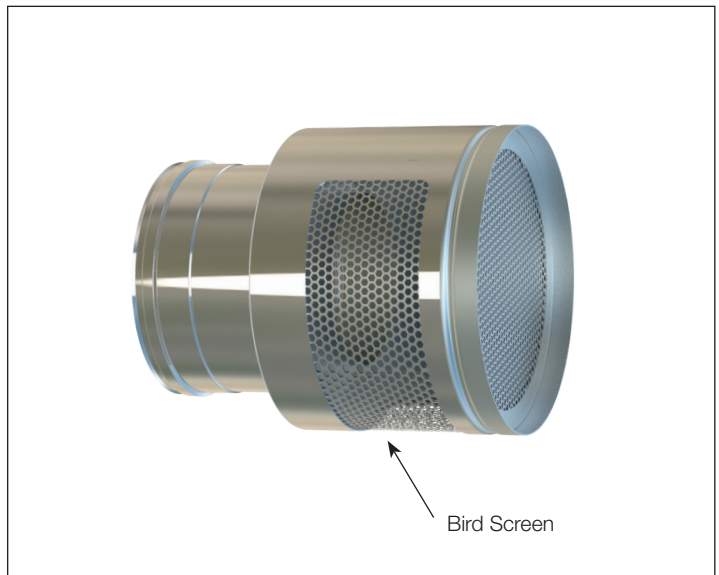

Fig 5-2: Side Wall Termination Cap

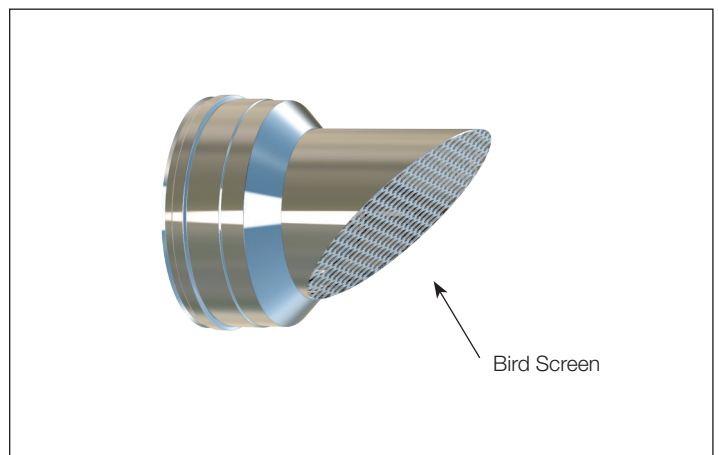

Fig 5-3: Mitre Cut Section

5.4 MITRE CUT SECTION

The Miter Cut is an alternative termination to a Side Wall Termination Cap. It has a 45° slope facing down.

5.5 FAN PLATE ADAPTER

This termination section includes a heavy gage flat plate that is used to attach a termination mechanical draft fan or exhaust fan. Available in all vent sizes.

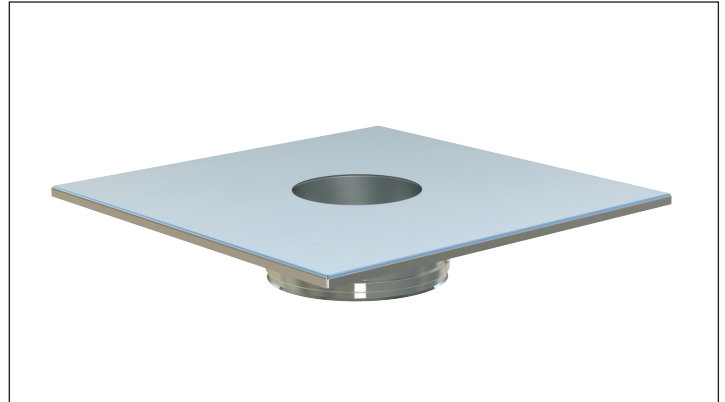

Fig 5-4: Fan Plate Adapter

5.6 FAN ADAPTER TERMINATION

The Fan Adapter Termination is a section of a EPSC+ that provides a surface for mounting and installing an up-blast discharge fan. Depending on the weight of a fan, the Fan Adapter Termination may eliminate the need for a separate welded fan curb termination assembly. It is specifically designed to accommodate hinged type exhaust fans.

Note: At present (2023), Underwriters Laboratories (UL) has no Safety Standards for these devices, so although they are shown in this document and condoned by ENERVEX and others, UL has not independently investigated this product.

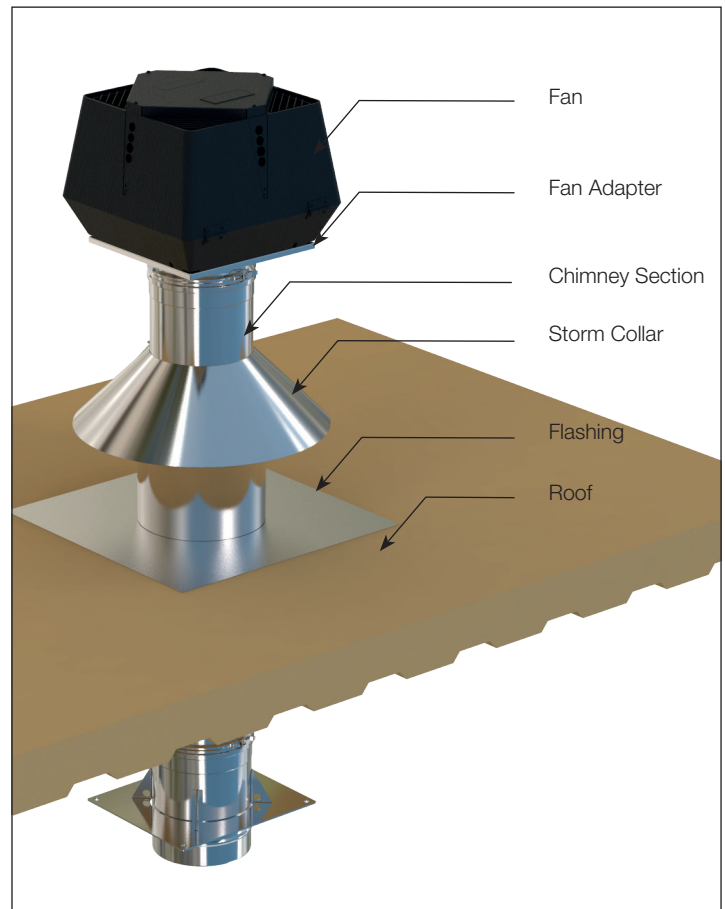

Fig 5-5: Fan Adapter Termination

6. STRUCTURAL SUPPORT AND GUIDE COMPONENTS

6.1 SUPPORT PLATE ASSEMBLY

The support plate assembly consists of a single bottom plate with a pair of top plates assembled around the central stack and bolted together using M10 hardware. Any standard length straight section can be used with the support plate assembly. The outermost edge on the female spigot rests on the top plates. The plate assembly must be adequately supported and braced back to the building structure with rigid structural members (by installer). All hardware included with the plate assembly must be used to connect the three plates together and to the support structure. A support plate assembly must always be used above an Adjustable Length in vertical applications or where the Adjustable Length would otherwise be subjected to load.

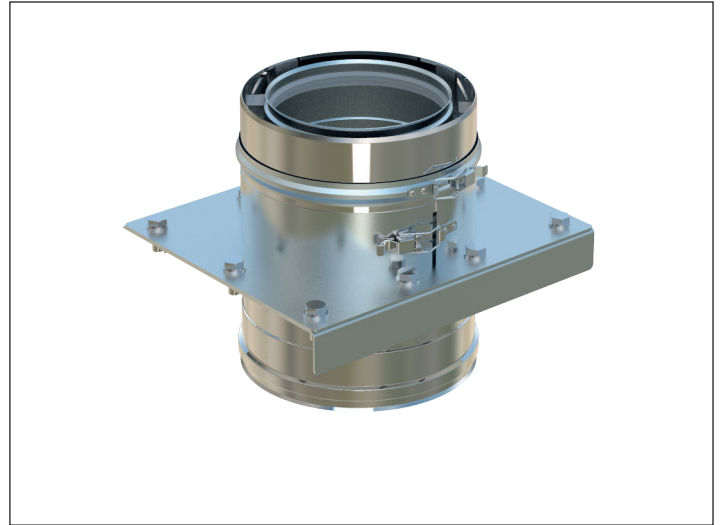

Fig 6-1: Support Plate Assembly

6.2 HORIZONTAL SUPPORT

The Plate Support is only suitable for installation and attachment to NON-COMBUSTIBLE surroundings. It must be secured to the building with a rigid structural framework. Never secure with threaded rod since this will not prevent pipe sway.

If bracing is used, the bracing angle "X" must be at least 30°. If bracing is not used, welded frame members must be attached to the structural members to provide rigidity of framework.



CAUTION

The Supports and Guides described here are only suitable for attachment to noncombustible construction.

6.3 WALL SUPPORT

The Wall Support consists of the same plate support as the support plate assembly, but includes wall support bracing. All hardware included with the assembly must be used when connecting the plates to the provided support brackets.

The assembly must be tightly bolted using all the nuts and bolts provided.

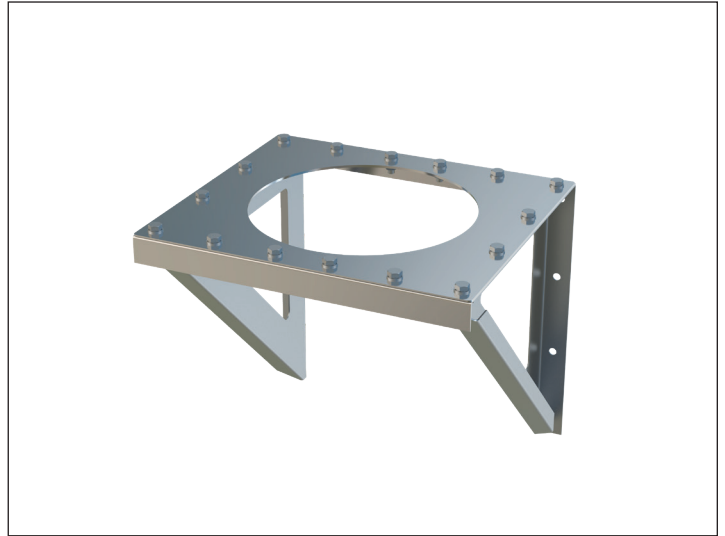

Fig 6-3: Wall Support

6.4 FLOOR GUIDE

The Floor Guide is used as a guide at a floor penetration. It is attached to the floor by means of (4) angle brackets. It maintains a minimum distance between the vent and combustible floor material.

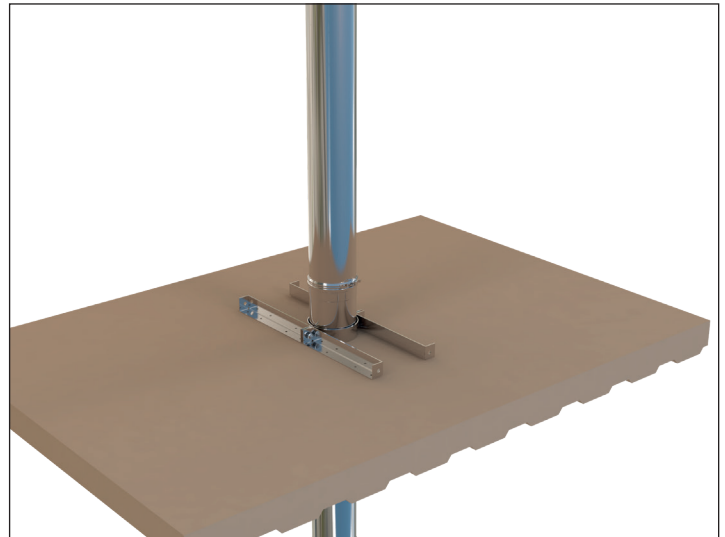

Fig 6-4: Floor Guide

6.5 WALL GUIDE

This component uses a Full Ring supplied with bracket, nuts and bolts for assembly. It does not include hardware for attachment to the structure. The latter must be provided by the installer and should be of sufficient and suitable strength to ensure adequate attachment.

The Wall Guide is designed to provide 2 inch (50mm) clearance from the outer wall of the venting system to non-combustible structures. The assembly is intended to resist lateral or side loads only, and must not be used to carry the weight of a vertical vent system.

This assembly shall not be used for attachment to combustible structures. If the vent must be attached to a combustible wall, spacers should be used to maintain minimum clearance required and also minimize heat conduction through supporting metal parts. The Ring inside diameter is 0.2" (5mm) larger than the outside diameter of the vent to allow for sliding movement during thermal expansion.

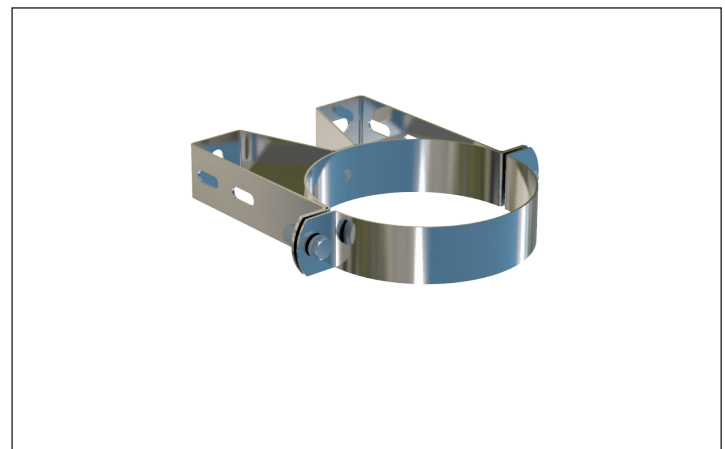

Fig 6-5: Wall Guide

6.6 FULL RING / HALF RING

The Full Ring may also be used as an expansion guide by attachment to a suitable structural steel frame. For a support cradle for horizontal run, Half Ring or Full Ring may be suspended by rods. Hole size is M8 or 5/16"

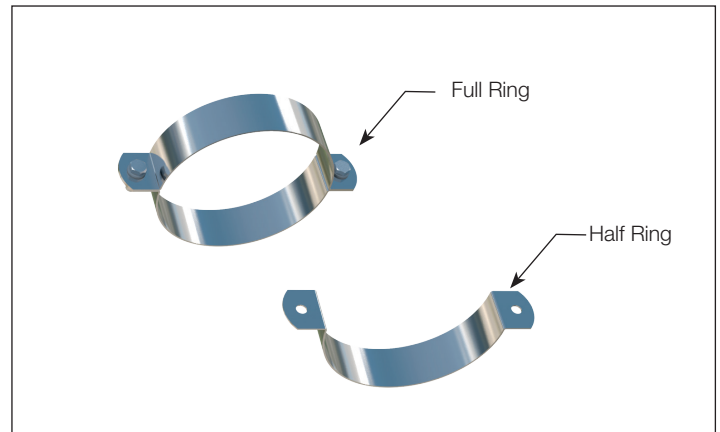

Fig 6-6: Full and Half FlatRings

6.7 GUY SECTION ASSEMBLY

The Guy Section Assembly is used when the free-standing part of the vent above the roof exceeds the limits according to table 1-7.



Fig 6-7: Guy Section Assembly

6.10 CENTERING BAND

Designed to insure proper centering of the vent inside an existing masonry chimney. Should be used every 13 feet (4m).

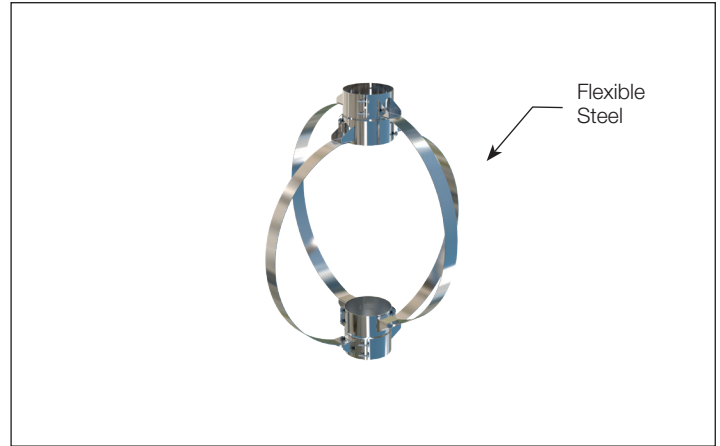

Fig 6-10: Centering Band

6.11 SUPPORTING TEES AND ELBOWS

Proper support of Elbows and Tees is critical. Both must be protected from thermal expansion and bending forces.

Below are some structural alternatives for stiffening Elbows using Plate Support or Wall Support Components.

Elbows and Tees are not load-bearing.

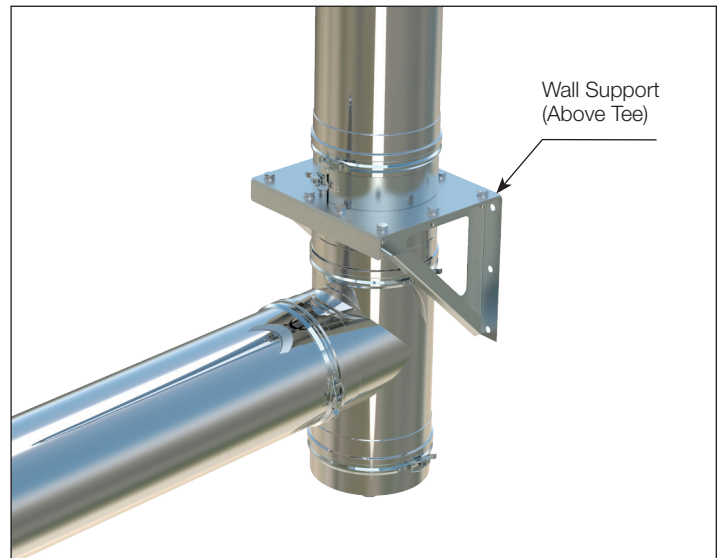

Fig 6-11: Tee Support Example

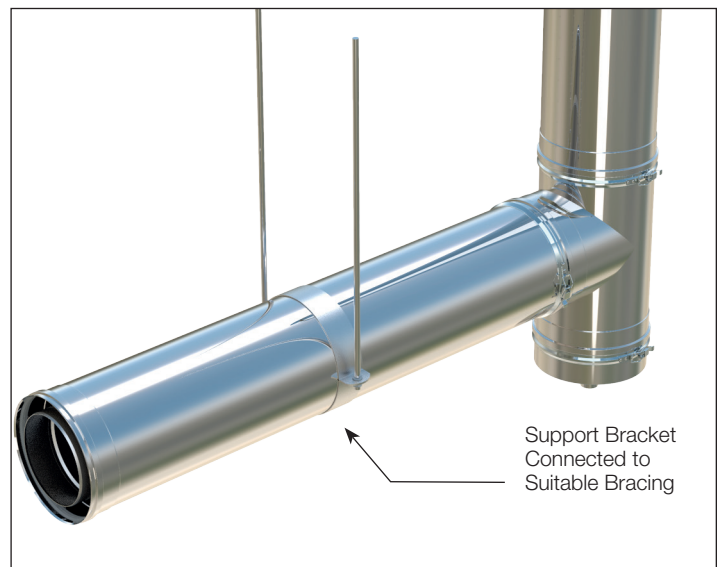

Fig 6-12: Horizontal Support Example

7. ROOF PENETRATIONS, THIMBLES AND FLASHING

7.1 UNVENTED INSULATED ROOF ASSEMBLY

The insulated penetration thimble, includes an insulated EPSC+ section and is primarily for the penetration of building roofs and walls of combustible construction. It can be installed with a wooden frame at a minimum of 1" (25mm) clearance, see Fig 7-2 for framing data.

1. Before installation remove the bottom Lateral Support Rings from the insulated thimble.
2. The thimble mounts directly to a level combustible structure using four 1/4 x 2 1/2" lag screws and extends down through the roof void and into the space below. Where the roof is not level, build a suitable level frame construction above the roof to offer a flat and structurally stable platform for the insulated thimble assembly using the framing dimensions of Fig 8-2.
3. Insert Insulated Roof Assembly from above. Secure to level roof deck or structure using the fixed brackets.
4. Position the Floor Guide around the underside of the thimble, bolt together with the nuts and bolts provide and secure to the ceiling using appropriate lag screws.
5. The Flat Flashing is then passed over the upper section of pipe and position so that the flashing skirt is centrally located over the frame.
6. The flashing is then weathered in the traditional way depending on the type of roof.
7. Locate the Storm Collar around the pipe and loosely tighten the hardware. Ensure that the Storm Collar is positioned and located directly down on to the upstand of the Flat Flashing.
8. When in position, fully tighten the hardware and apply a bead of weather resistance sealant around the interface between the top of the Storm Collar cone and the overlap joint of the pipe in order to provide a suitable weather seal.

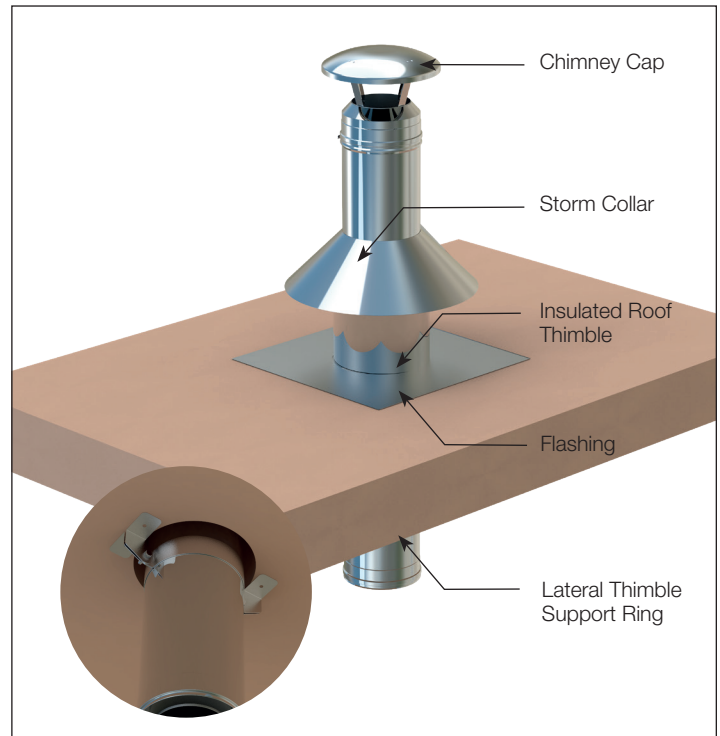

Fig 7-1: Roof Assembly Details

CHIMNEY SIZE inch (mm)	ROOF PENETRATION FRAMING DIMENSION (A) EPSC+ inch (mm)
4 (100)	8 (203)
5 (130)	9.25 (235)
6 (150)	10 (254)
7 (180)	11.25 (286)
8 (200)	12 (305)
10 (250)	14 (356)
12 (300)	16 (406)
14 (350)	18 (457)

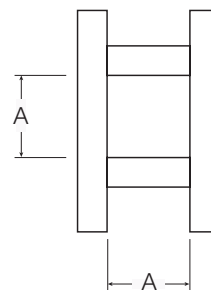

Fig 7-2: Framing Dimensions

CHIMNEY SIZE inch (mm)	WALL PENETRATION FRAMING DIMENSION (A) EPSC+ inch (mm)
4 (100)	8.5 (216)
5 (130)	9.75 (248)
6 (150)	10.5 (267)
7 (180)	11.75 (298)
8 (200)	14.5 (368)
10 (250)	16.5 (419)
12 (300)	18.5 (470)
14 (350)	22.5 (572)

7.2 WALL PENETRATION

Prior to installation, determine proper location of wall thimble so that a minimum slope of 1/4" (6mm) per foot is maintained in the horizontal section of vent to ensure proper flow of condensation.

Prepare the wall by cutting a square opening.

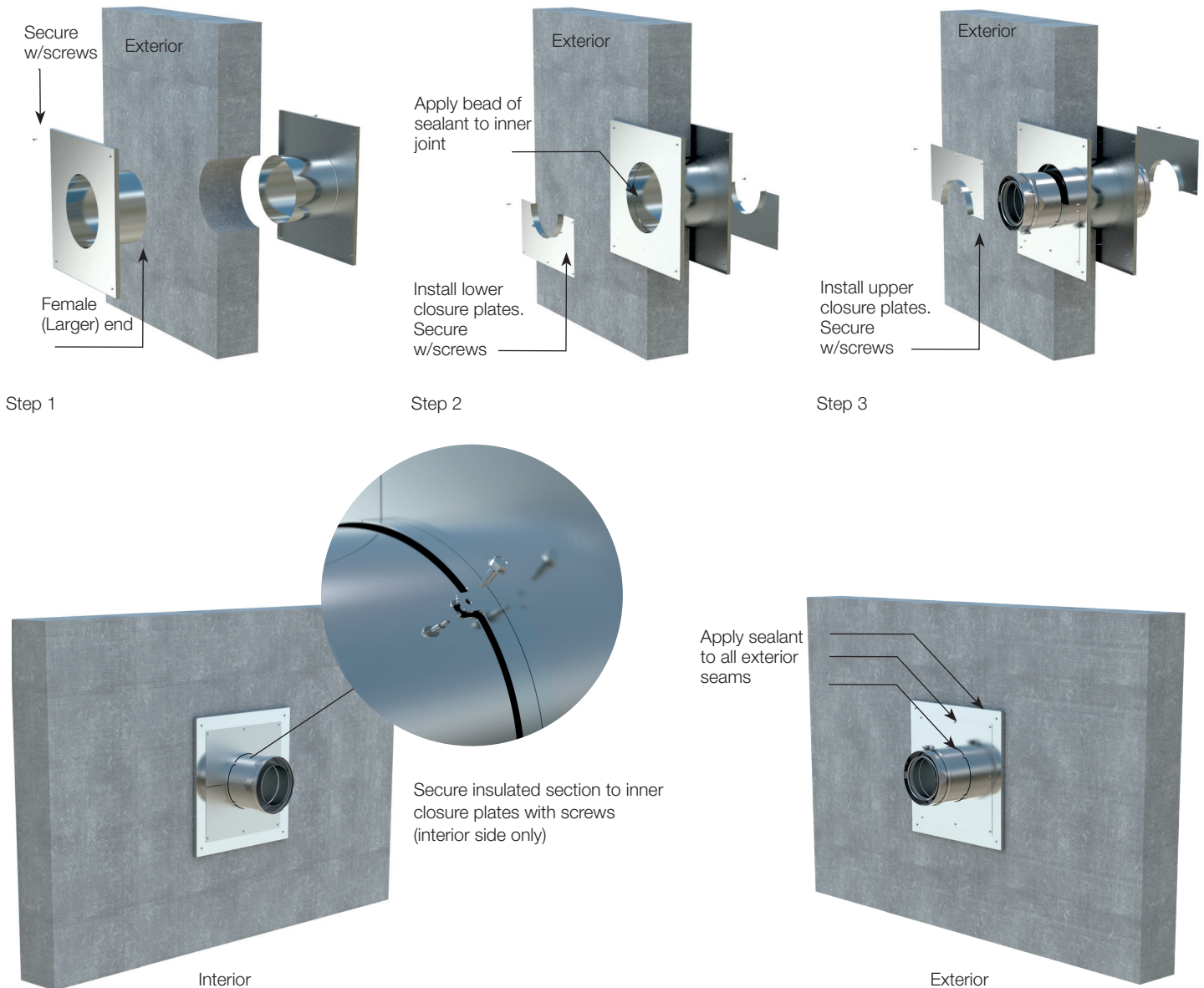

Fig 7-2: Wall Penetration

7.3 FLASHINGS AND STORM COLLARS

Flat Flashings and Adjustable Flashings (5°-30°/32°-45°) will permit weathering where the vent passes through the roof structure. The drawing shows a typical application and features the use of the Storm Collar to weatherproof the flashing cone/outer casing interface. Please note that the vent must be allowed to ride vertically through the cone of the flashing under expansion conditions.

The Storm Collar must be secured and sealed with the provided sealant to the outer casing of the vent.

Locate as close to the top of the cone of the flashing as possible so that despite expansion, weatherproofing is maintained.

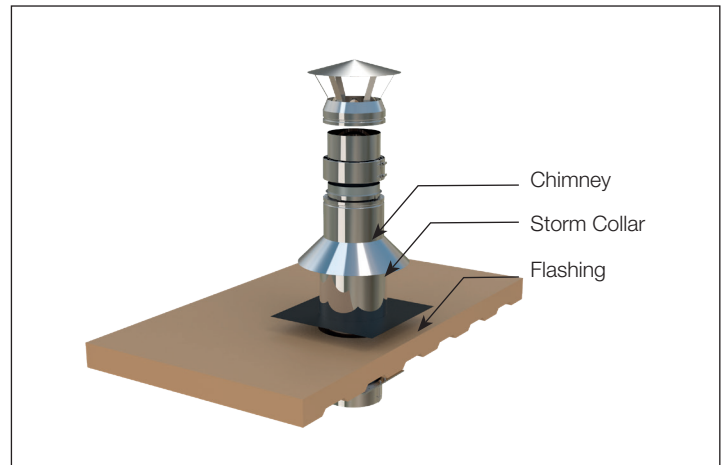

Fig 7-3: Flashing and Storm Collar Installation Details

8. MISC. COMPONENTS

8.1 TRANSITIONS TO EPS, EPSA, EPS1, EPS2 AND EPS4 WITH FLANGED CONNECTIONS

This transition section is used when connecting EPSC+ to EPS, EPSA, EPS, EPS2 and EPS4 chimneys with flanged connections.

The transition can also be used when connecting the EPSC+ to a TDF inline power venter.

The connection to the power venter is customized for the appropriate diameter.



Fig 8-1

8.2 OTHER TRANSITIONS

ENERVEX supplies other types of custom-made transitions. Shown here is a step-transition from a standard 1/2" flanged vent to a larger 1/2" flanged vent or other object.

9. WARRANTY

9.1 STANDARD 1-YEAR WARRANTY

ENERVEX Inc. ("ENERVEX") warrants the vent and components against functional failure due to defects in material and workmanship for a period of one year from date of delivery to the construction site. Functional failure is defined as any failure of the system or component to perform its intended function of exhausting, without adverse leakage, combustion by-products from engine operation or heating equipment. During this period, any system or component supplied by ENERVEX failing to perform its intended function will be repaired or replaced at the manufacturer's option, following determination by a factory-authorized inspector that a functional failure has occurred. This warranty is limited to repair or replacement of the product plus shipping cost to the failure location. This warranty does not cover any labor costs for removal or replacement of the defective product, nor does this warranty cover any system components not furnished by ENERVEX and installed as part of the system.

This limited warranty is extended to the purchaser subject to the satisfaction of the following conditions:

- 1) Generally accepted engineering practices have been followed to determine that sizing and material specifications are suitable for the application and environment involved.
- 2) The undamaged components have been correctly installed in accordance with the installation instructions published by ENERVEX at the time of shipment.
- 3) Damage is not a result of burning garbage, waste oil, #6 oil or any other prohibitive material in the appliance served by the venting system.

9.2 EXTENDED 15-YEAR WARRANTY

This limited warranty is extended to the purchaser for fifteen years, subject to the satisfaction of the following conditions:

- 1) System sizing and design has been performed by ENERVEX personnel, and design parameters provided to ENERVEX by the responsible engineer were and are accurately representative of the operating conditions.
- 2) The undamaged components have been correctly installed in accordance with system design and sizing as performed by ENERVEX and installation instructions published by ENERVEX at the time of shipment.
- 3) Proper precautions have been taken to insure that boiler or engine combustion air is free of solvent or refrigerant vapors or any halogenated compound which may cause acid condensates to form within the chimney.
- 4) Damage is not a result of burning garbage, waste oil, #6 oil or any other prohibitive material in the appliance served by the venting system.
- 5) ENERVEX has supplied the entire chimney or exhaust system from boiler/engine outlet to the termination of the vent. The ENERVEX 15&1 Warranty applies to EPSC+ used in Residential/Commercial/Industrial/Institutional applications.

Disclaimer:

ENERVEX assumes no liability for incidental or consequential damages of any kind or for any damages resulting in whole or in part from misuse, improper installation, or inadequate maintenance of the system or any component part thereof.

This warranty is in lieu of all other express warranties or guarantees of any kind. All implied warranties, including merchantability and fitness, are limited to the duration of the express warranty contained herein. ENERVEX neither assumes nor does it authorize any other person to assume on its behalf any other liability in connection with the sale of its products.

ANY IMPLIED WARRANTY OF MERCHANTABILITY OR FITNESS FOR A PARTICULAR PURPOSE IS LIMITED IN DURATION TO THE WARRANTY PERIOD SPECIFIED ABOVE. WE DISCLAIM ANY LIABILITY FOR CONSEQUENTIAL OR INCIDENTAL DAMAGES AND ANY LOSS OR EXPENSE(S), NOT SPECIFIED ABOVE. SOME STATES MAY NOT ALLOW THE EXCLUSION OR LIMITATION OF INCIDENTAL OR CONSEQUENTIAL DAMAGES, OR HOW LONG AN IMPLIED WARRANTY LASTS, SO THE ABOVE EXCLUSIONS OR LIMITATIONS MAY NOT APPLY TO YOU. THIS WARRANTY GIVES YOU SPECIFIC LEGAL RIGHTS AND YOU MAY ALSO HAVE LEGAL RIGHTS WHICH VARY FROM STATE TO STATE OR PROVINCE TO PROVINCE.