

ENERVEX®

TDF 500 POWER VENTER

020.1095.0619 12.24

Product Information

Use

The TDF Power Venter is a true in-line power venter. It is specifically designed for applications where reliable and efficient operation, low noise level, low energy consumption, variable speed and compact design are of utmost importance.

Typical applications are: mechanical venting of gas-fired or oil-fired boilers and water heaters. For indoor or outdoor installation.

Description

The TDF Power Venter is an efficient, high-temperature ventilator with backward-inclined impeller. It can be installed horizontally or vertically in a chimney system.

The fan housing is made of stainless steel and equipped with an energy-efficient, totally enclosed, variable speed motor, which is mounted outside the air stream.

The complete drive unit (motor, impeller and mounting plates) can be removed from the fan without the need for removing the housing from the stack system.

The TDF is for use with condensing and non-condensing appliances operating where flue gas temperatures do not exceed 1400°F (760°C).

The TDF model is a component in the CASI, Chimney Automation System.

Material

The housing is made of 316L stainless steel and has flanged connection. The impeller is of the backward inclined type made of 316L stainless steel.

Motor

The motor is a TEFC air cooled, maintenance-free variable speed permanent magnet motor with pre-lubricated and sealed ball bearings and a Class H temperature rating. The motor with controller is rated at 92% efficiency and able to operate as low as 50 RPM. It has integrated protection against overloading, blocking over and under voltage and over-heating. The motor shaft is internally isolated to eliminate the need for external shaft grounding. It is rated for outdoor installation.

The included EDrive motor control (NEMA4X) is factory programmed by ENERVEX for optimal operation of the ventilator.

Standard Equipment

- EDrive Motor Control
- V-Bands (where used)



UL File E467733
UL File MH63636
Specifications are subject to change without notice.

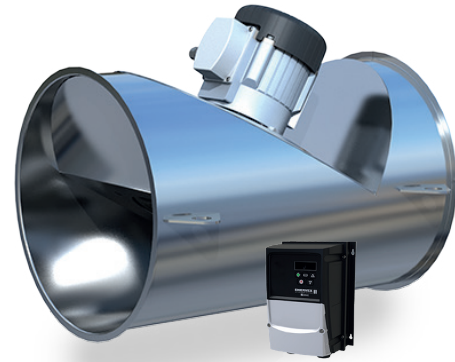

Optional Accessories

- EBC 30/31 Modulating Pressure Controller
- EBC 35 Modulating Pressure Controller
- EBC 24 Modulating Pressure Controller
- BDC 8 Modulating Pressure Controller

Listings

UL Listing under Category MCQX and ZACT under File No. MH63636 and reference to the following standards:

- UL 378 Standard for Draft Equipment Edition 4
- UL 705 Standard for Power Ventilators Edition 7
- CSA C22.2 No. 113-18 Fans and Ventilators Edition 11
- ULC/ORD-C378-75 Guide for the Investigation of Draft Equipment Edition 1

Warranty

- 2-Year Factory Warranty
- 10-Year Warranty Against Corrosion Perforation

Complete warranty conditions are available from ENERVEX Inc.

ENERVEX Inc.
1685 Bluegrass Lakes Parkway
Alpharetta, GA 30004
USA

P: 770.587.3238
F: 770.587.4731
T: 800.255.2923
info@enervex.com
www.enervex.com

ENERVEX®
VENTING DESIGN SOLUTIONS

A stylized red graphic element consisting of three vertical bars of varying heights, resembling a flame or a vent stack, positioned to the right of the company name.

ENERVEX® TDF 500 POWER VENTER

020.1095.0619 12.24

Product Information

Specifications

Model	TDF 500	
Fan Type	Centrifugal Impeller (BC-Wheel)	
Motor Type	ECM, Permanent Magnet	
Voltage Configuration	3 x 208-240 VAC	3 x 380-480 VAC
EDrive Model	321.0914.2200	321.0914.4200
EDrive Ratings:		
NEMA / IP Rating	4X / IP66	4X / IP66
Supply Voltage - VAC	3 x 208-240	3 x 380-480
Power - kW	4.0	4.0
Max Input Current - Amp	20.9	11.5
Max Output Current - Amp	18.0	9.5
Max Over-Current - %	175	175
Min Operating Temp. - °F / °C	-4 / -20	
Max Operating Temp. - °F / °C	104 / 40	
Motor Ratings:		
Motor Efficiency Class	IE5	IE5
Temperature Class	H	H
NEMA / IP Rating	3S / IP55	3S / IP55
Max Current - Amp	12.6	7.3
Max Speed - RPM	2500	2500
Power - kW / HP	3.0 / 4.0	3.0 / 4.0
Torque - Nm	14	14
Motor Operating Settings:		
Fan Speed - RPM	1950	1950
Max Power - kW / ~ HP	2.8 / 3.75	2.8 / 3.75
Max Torque - Nm	13.2	13.2
Weight:		
TDF - lbs / kg	164 / 75	
EDrive - lbs / kg	15.4 / 7.0	7.7 / 3.5

Note: Use EDrive Ratings Data for Circuit Sizing

Dimensions

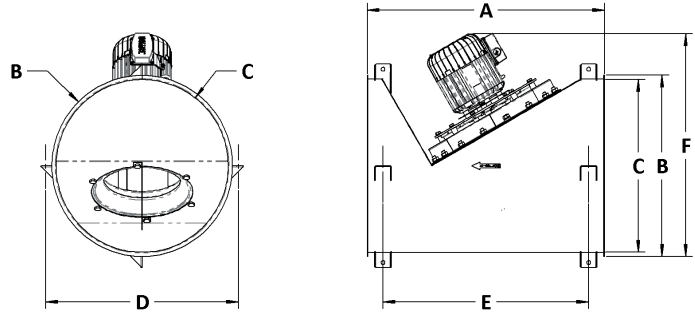

Model	TDF 500	
Duct Connection	½" flange	
Dimensions	A in / mm	39.4 / 1000
	B in / mm	29.0 / 736
	C in / mm	28.0 / 711
	D in / mm	30.4 / 772
	E in / mm	34.9 / 887
	F in / mm	33.1 / 840
Flange Bolt Center Diameter	in / mm	- / -
Temp Rating*	°F / °C	1400 / 760

* Maximum Intermittent Temperature Rating

Capacity

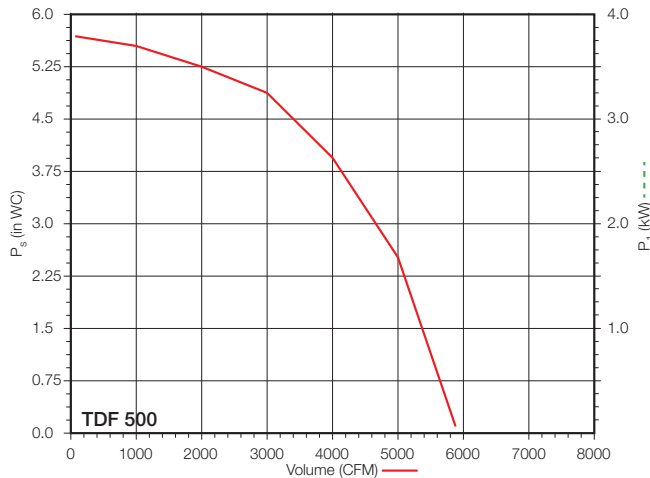

Specifications are subject to change without notice.

Sound Table

SP	Sound Power re 10 ⁻¹² Watts								Sones	L _{wo} A
	Octave Bands									
	1	2	3	4	5	6	7	8		
0.00	88	88	86	85	80	79	73	76	42	77
2.00	84	84	82	81	76	71	69	72	35	73
4.00	80	80	78	77	72	71	65	68	29	69
6.00	83	83	81	80	75	74	68	71	33	72

Values shown are for outlet L_{wo}A sound power levels for Installation Type C: ducted inlet, free outlet. The sound power level ratings shown are in decibels, referred to 10-12 watts, calculated per AMCA International Standard 301. The A-weighted sound ratings shown have been calculated per AMCA International Standard 301. The sound ratings shown are loudness values in fan zones at a distance of 1.5 m (5 ft) in a hemispherical free field calculated per AMCA International Standard 301. Values shown are for free outlet hemispherical sone levels. dBA levels are not licensed by AMCA International.

ENERVEX Inc.
1685 Bluegrass Lakes Parkway
Alpharetta, GA 30004
USA

P: 770.587.3238
F: 770.587.4731
T: 800.255.2923
info@enervex.com
www.enervex.com

ENERVEX®
VENTING DESIGN SOLUTIONS