

MECHANICAL DRAFT SYSTEMS

INNOVATIVE ONE-STOP DESIGN FOR ANY EXHAUST APPLICATION

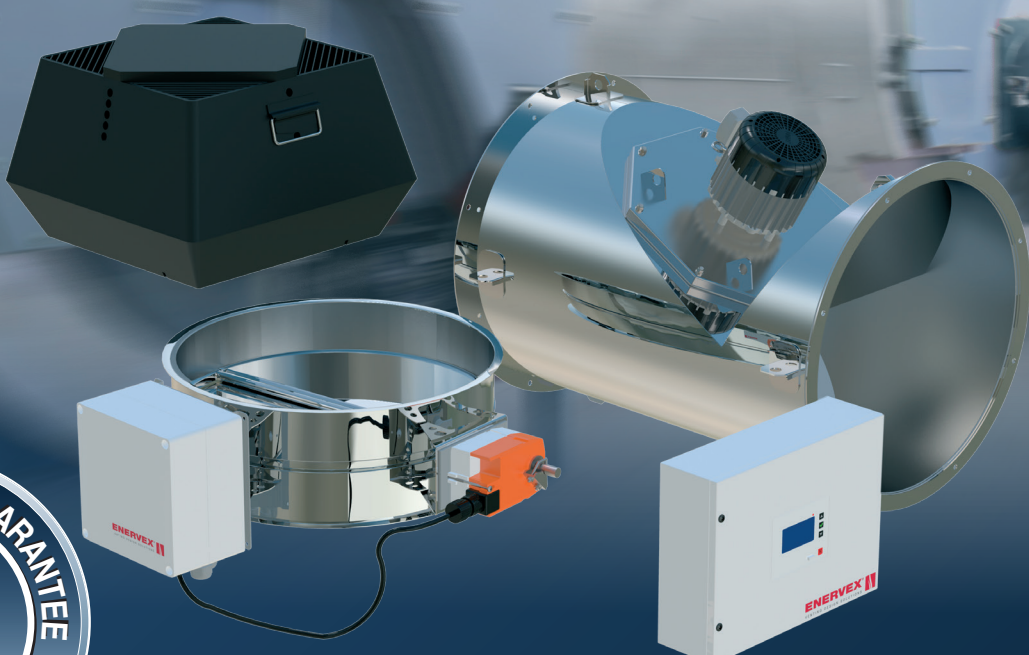

Simple. Seamless. Smart.

ENERVEX[®] 
VENTING DESIGN SOLUTIONS

T: +1 800.255.2923 · www.enervex.com

INDUSTRY-FIRST DESIGN INNOVATION

ENERVEX continues to lead the industry in the original design of powerhouse mechanical draft products that deliver consistent savings, ease of installation and performance. Our fan-based and damper-based systems cover a wide variety of applications to meet today's demanding commercial exhaust challenges:

**INADEQUATE OR EXCESSIVE DRAFT, TALL CHIMNEYS,
CHALLENGING CHIMNEY DESIGN, EQUIPMENT OPERATING
PROBLEMS, VARIABLE AND SEASONAL DEMANDS, CODE
PROBLEMS AND MUCH MORE.**

Our innovative demand-controlled systems solve these market challenges and drive measurable advantages.

ENERVEX ADVANTAGES



ONE-STOP-DESIGN

Products built to work together guarantees seamless integration; single-supplier responsibility eliminates guesswork and blame game.



DESIGNER FRIENDLY

For any building type, for any appliance type. Proven solutions that deliver performance every time. And all components are UL or ETL listed.



INSTALLER FRIENDLY

Perfect fit for any chimney system. Simple and seamless installation with "plug-and-play" makes integration easy.



PERFECT DRAFT

Consistent performance and reliability. Optimizes equipment performance and fuel efficiency.



File No. MH61178

INNOVATION

ENERVEX is the single-most innovative manufacturer of mechanical draft system designs. We're not just rebranding existing designs; ENERVEX has a long list of industry firsts in the design of original exhaust products that have a purpose.

From the first chimney fan in 1958, the first modulating mechanical draft system in 1991, the first multi-purpose draft and pressure controller in 1998, the first true inline mechanical draft fan in 2006, the first multi-purpose chimney system in 2014, the first full-line mechanical draft fans with EC-motor technology (2015), the first BACnet and Modbus draft controllers (2016) and beyond – ENERVEX continues a history of creating authentic firsts.

MANY APPLICATIONS

ENERVEX offers fan-based and damper-based mechanical draft systems to actively control draft and save significant energy/costs by operating only when needed. Our one-stop designs can be installed effortlessly for many different commercial applications:

**DEMAND-CONTROLLED EXHAUST FOR:
BOILERS & WATER HEATERS, CO-GENS
TUNNEL OVENS, PROCESS OVENS,
EMERGENCY GENERATORS AND MORE**

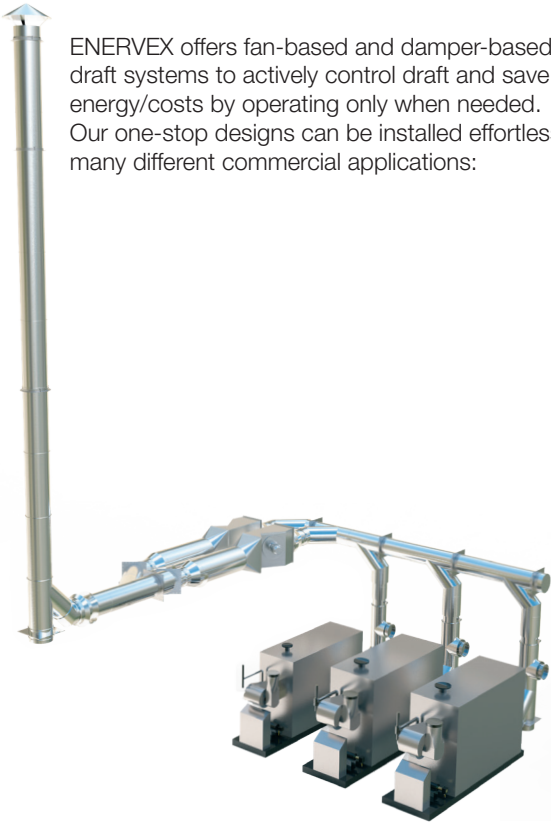

BOILERS & WATER HEATERS



PIZZA OVENS

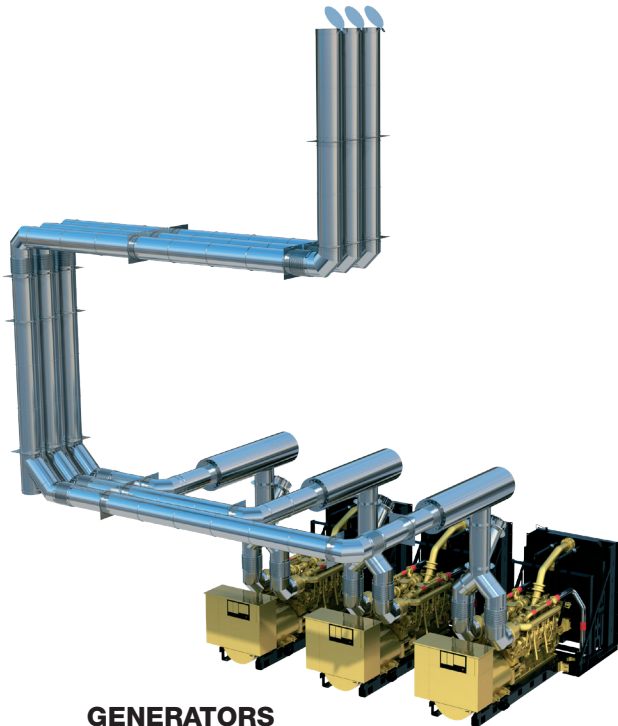

GENERATORS

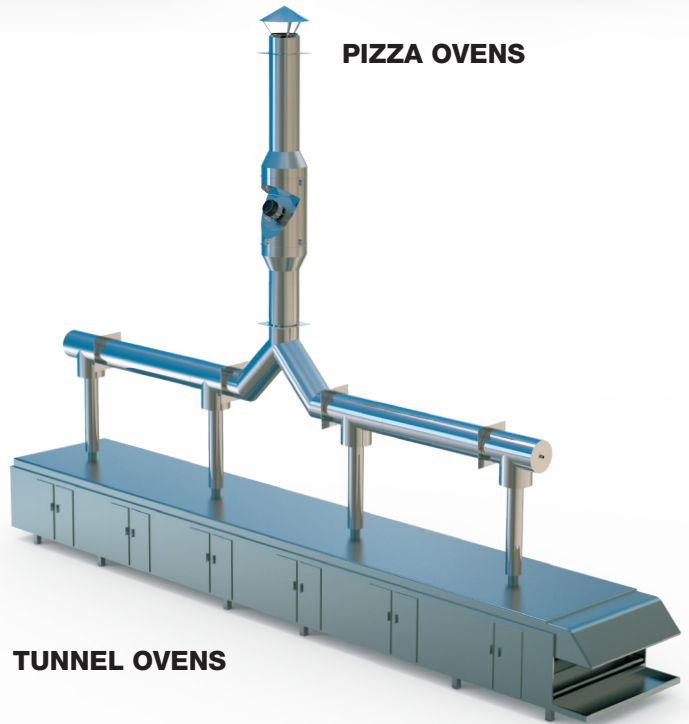

TUNNEL OVENS

THE SYSTEMS SEAMLESS PERFORMANCE. GUARANTEED.

ENERVEX's line of listed, fully integrated mechanical draft systems provide a truly one-stop design from boiler outlet to chimney termination. Our systems are economical, environmentally sustainable, aesthetically pleasing, reliable and up to code for commercial projects around the globe.

All systems and related products are engineered by one manufacturer, which means they will work together seamlessly. No more guesswork or finger pointing in the design process – and the flexibility to add what you need, when you need it.



CASV / CASI

CHIMNEY AUTOMATION SYSTEM (INLINE & TERMINATION)

The Chimney Automation System delivers state-of-the-art, multi-application exhaust for boilers, water heaters, ovens and much more. It is a demand-controlled exhaust system that actively controls draft or pressure and includes:

- TDF mechanical draft fan with EDrive for installation inline or RSV or TDF-VP at the termination (RSV or TDF-VP).
- EBC 31 Modulating Draft Controller that can simultaneously operate and control a mechanical draft fan, a draft damper and combustion air supply. It is fully programmable and includes BACnet protocol.
- XTP sensor with stack probe set up for uni-directional or bi-directional pressure.

The EBC31 maintains a constant draft by modulating the speed of the mechanical draft fan. The integrated safety system prevents operation during power failure or mechanical failure as required by mechanical codes. The system will usually require the use of ADF Automatic Dampers or BBF Balancing Dampers, if multiple appliances are served. They are used to balance the draft or close an idle appliance connector.



MCAS

MODULATING COMBUSTION AIR SUPPLY SYSTEM

The Modulating Combustion Air Supply System is used to supply combustion air for boilers, water heaters, ovens and much more. It is a demand-controlled air supply system that actively controls the supply of combustion air to individual boilers – or to the mechanical room in general. It includes:

- A supply fan (BEF_x or SFTA).
- EBC 31 Modulating Draft Controller that can simultaneously operate and control a mechanical draft fan, a draft damper and combustion air supply. It is fully programmable and includes BACnet protocol.
- XTP sensor and outdoor pressure probe.

The EBC31 maintains a constant pressure for the connected appliance(s) or the mechanical room by modulating the speed of the supply fan. The integrated safety system prevents operation during power failure or mechanical failure as required by mechanical codes.

The system may require the use of BBF Balancing Dampers if combustion air is served directly to individual appliances.

FLEXIBLE, ONE-STOP DESIGN
FULLY PACKAGED SYSTEMS
EASY SYSTEM INTEGRATION
SOLUTIONS FOR ANY APPLICATION
SINGLE-SUPPLIER RESPONSIBILITY & SUPPORT

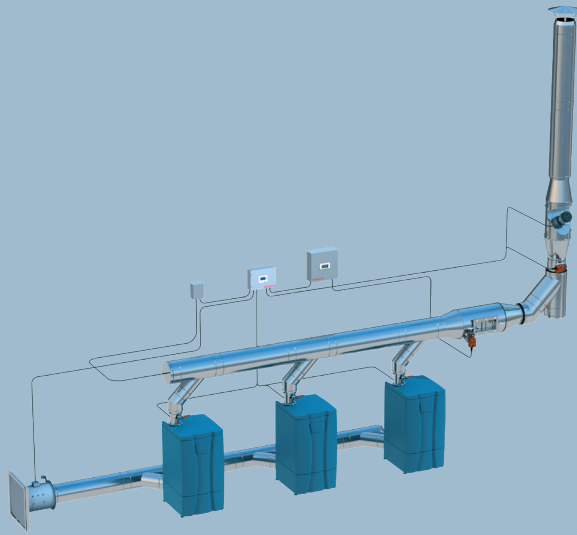

MODS

MODULATING OVERDRAFT DAMPER SYSTEM

The Modulating Overdraft Damper System is a single or multi-application draft control for boilers, water heaters, ovens and much more operating under excessive natural draft conditions. It is a demand-controlled damper system that actively controls/limits draft and includes:

- A multi-blade draft damper (MDF).
- EBC 31 Modulating Draft Controller that can simultaneously operate and control a mechanical draft fan, a draft damper and combustion air supply. It is fully programmable and includes BACnet protocol.
- XTP sensor with stack probe set up for uni-directional or bi-directional pressure.

The EBC31 maintains a constant draft for the connected appliance(s) by modulating the position of the damper blades. The integrated safety system prevents operation during power failure or mechanical failure as required by mechanical codes.



SMDS

SEALED MODULATING DAMPER SYSTEM

The Sealed Modulating Damper System (SMDS) maintains a required pressure (negative or positive) for a common chimney or at individual appliance connector(s). It can be used with Category I, II, III & IV heating appliance systems and includes:

- ADF Damper with high-pressure and high-temperature sealed bearings.
- The damper blade is positively sealed with an extremely durable, temperature, pressure and condensate resistant graphite gasket. (For low-temperature applications, a Viton gasket may be used.)
- The damper is controlled by an EBC24 Draft Controller that interlocks with the heating appliance(s) and controls the pressure using a bi-directional XTP Pressure Sensor.

THE PRODUCTS

ENERVEX's wide range of integrated fans, dampers, controllers ensure your mechanical draft system components will work together properly, with no surprises in the field.

These products ensure your exhaust system can protect against improper draft or pressure, inconsistent supply of make-up/combustion air, and mechanical or electrical failures.

MECHANICAL DRAFT FANS – INLINE

The inline versions include TDF and BPV. Both are ruggedly built mechanical draft fan made entirely in stainless steel 316L. They use an EC-motor and are supplied with pre-programmed EDrives for motor speed control. UL-listed for temperatures up to 1400°F (760°C).

The TDF is a true inline fan with inlet and outlet on same center-line in a single-wall designed housing (insulation optional). The BPV's inlet and outlet are offset 90° and the housing is double-wall insulated.

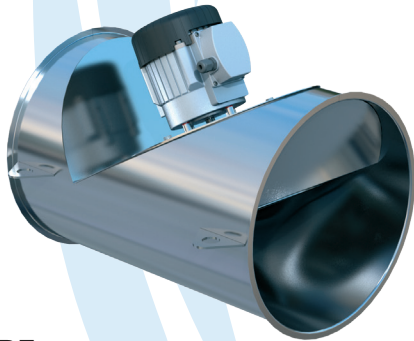

TDF

- 0-29,000 CFM (450-49,300 m3/h)
- ½" flanges or bolt-flanges
- Stainless Steel 316L Housing and Backward-curved Impeller
- EC-Motor, TEFC, Class H w/ insulated rotor/shaft system and stainless-steel shaft
- 1400°F (760°C) / 1800° (980°C) intermittent Temp Rating
- 2-Year Factory Warranty, 10-Year Warranty Against Corrosion Perforation
- UL 378, UL 705, CSA3-B255-M81, CSA C22.2 No. 113-12 Listings

PROVEN PRODUCTS & SOLUTIONS

EXTREME RELIABILITY

PERFECT FITS

ADD WHAT YOU NEED, WHEN YOU NEED IT.

MECHANICAL DRAFT FANS – TERMINATION

These models - RSV and TDF-VP - both discharge vertically. The TDF-VP is for applications where a high discharge velocity or plume dilution is required. The RSV features a clam-shell design and is made entirely in cast aluminum. The TDF-VP is made entirely in stainless-steel 316L and uses an EC-motor and is UL-listed for temperatures up to 1400°F (760°C).



RSV

- 400-4,000 CFM (0-6,800 m3/h)
- Cast Aluminum Housing and Impeller
- Backward-curved Impeller
- Variable Speed, TEFC, Class H
- 575°F (300°C) Temp Rating
- 2-Year Factory Warranty, 10-Year Warranty Against Corrosion Perforation
- UL 378, UL 705, CSA3-B255-M81, CSA C22.2 No. 113-12 Listings



TDF-VP

- 0-29,000 CFM (450-49,300 m3/h)
- ½" flanges or bolt-flanges
- Stainless Steel 316L Housing and Backward-curved Impeller
- EC-Motor, TEFC, Class H w/ insulated rotor/shaft system and stainless-steel shaft
- 1400°F (760°C) / 1800° (980°C) intermittent Temp Rating
- 2-Year Factory Warranty, 10-Year Warranty Against Corrosion Perforation
- UL 378, UL 705, CSA3-B255-M81, CSA C22.2 No. 113-12 Listings

DRAFT CONTROL DAMPERS

The line of draft control dampers includes MDF, ADF and BBF. They are made in stainless steel 316L and have 1/2" flanges. Slip-fittings (male/male) are available (MDM, ADM and BBM). The dampers are UL-listed for 1400°F and are fitted complete with actuators (except BBF) and pressure/liquid tight shaft bearings.

MDF is a multi-blade damper used for overdraft control applications. ADF can be used as a balancing vent damper (OPEN/CLOSE) or to control outlet pressure of a boiler (MODULATING) and is available with graphite gasket, viton gasket or without gasket. The BBF is strictly a permanently fixed draft balancing damper.

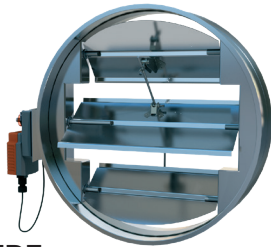

MDF

- 6" to 48" (150mm to 1200mm)
- 1/2" Flanges (slip-fittings optional)
- Stainless Steel 316L
- 24VAC/VDC Brushless Motor
- 54 in-lbs (6 Nm) Torque
- 90° in 15 Sec.
- 2 End Switches
- 1400°F (760°C)/1800°F (980°C) intermittent Temp Rating
- 2-year Factory Warranty
- UL 378, ULC/ORD-C378 (1975) Listing



ADF

- 4" to 36" (100mm to 900mm)
- 1/2" Flanges (slip-fittings optional)
- Stainless Steel 316L
- 24VAC/VDC or 120VAC Brushless Motor
- 54 in-lbs (6 Nm) Torque
- 90° in 15 Sec.
- 2 End Switches
- 1400°F (760°C)/1800°F (980°C) intermittent Temp Rating
- 2-year Factory Warranty
- UL 378, ULC/ORD-C378 (1975) Listing



BBF

- 6" to 36" (150mm to 900mm)
- 1/2" Flanges (slip-fittings optional)
- Stainless Steel 316L
- 1400°F (760°C)/1800°F (980°C) intermittent Temp Rating
- 2-year Factory Warranty
- UL 378, ULC/ORD-C378 Listed

DRAFT CONTROLS

The EBC 24 and 31 are multi-use draft or pressure controllers used with fans and dampers to monitor and maintain a constant draft or pressure by varying the speed of a fan(s) or the position of an actuator. The BDC 26 is a redundancy controller used in conjunction with the EBC 31 controller.



EBC 31

- Controls exhaust fan, damper and supply fan via individual PID loops.
- "Plug-n-Play" monitors all terminals and registers components attached
- 0-10V signal for Edrive or actuator control
- LCD Graphical Display
- Integrated webserver for remote monitoring, configuration and firmware upgrade
- USB interface
- Interlock with up to 6 heating appliances
- Programmable operating range and bi-directional or uni-directional pressure sensing
- Integrated safety system with priority operation function
- Intermittent or continuous operation
- Integrated BACnet protocol



EBC 24

- Controls exhaust fan, damper or supply fan via PID loop.
- "Plug-n-Play" monitors all terminals and registers components attached
- 0-10V signal for Edrive or actuator control
- Programmable operating range and bi-directional or uni-directional pressure sensing
- LCD Graphical Display
- Interlock with up to 2 heating appliances
- Integrated safety system
- Priority operation function
- Integrated Modbus protocol

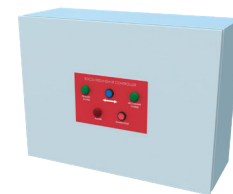

BDC 26

- Controls redundant mechanical draft systems with individual EBC controls
- Switch Operation of Primary Fan to the Secondary Fan in an alarm and/or time-out event.
- Operate one of two fans independent of each other based on boiler demand.
- Allows operator to manually switch between the Primary and Secondary fans when no alarms are present.
- Go into 'Alarm State' with visual and auditory announcement if an alarm condition is present on either the primary or secondary unit.
- Manual pushbutton reset of 'Alarm State' Hardware:

ADVANCED FEATURES

We are leading the industry in the original design of powerhouse mechanical draft products that deliver unique designs, reliable solutions, ease of installation and performance.

Our lead is the result of innovation and attention to detail. And the understanding of the needs of the customer, engineer and installer.

Some of the things we do may not seem like a big deal. Here's a review of some of the more advanced features and explanations of why they may be a big deal after all:

EC-MOTORS FOR ENERGY EFFICIENCY

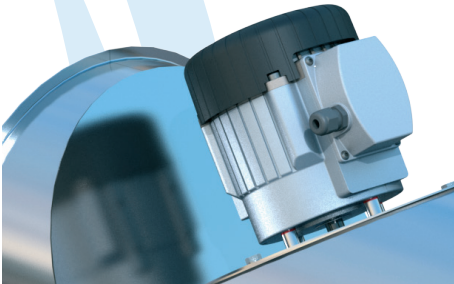

We have integrated electronically commutated motors (EC Motors) in most of our fan products all the way up to 30HP. EC motors are extremely efficient and meet not only current energy efficiency requirements, but also those of the foreseeable future. And they are extremely reliable even under high temperature conditions.

HIGH-VELOCITY EXHAUST AND PLUME DILUTION



Condensing boilers and their exhaust plumes have become an issue due to their visual presence. Ice build-up on chimney terminations can block a chimney, build-up on roofs can lead to falling ice and other potentially hazardous situations. The development of a high exit velocity and plume dilution TDF-VP addresses this real set of challenges.

RELIABILITY & DRIVE UNITS



Any downtime should be reduced to an absolute minimum. By design our products are reliable and serviceable. Our "drive unit" design allows a motor or impeller replacement in 30 minutes or less. Disconnect power and wiring, remove 12 bolts and lift the entire motor and impeller assembly out of the fan housing. Drop a new drive unit into the housing, secure 12 bolts, connect wiring and re-connect power.

REDUNDANCY FOR CRITICAL INSTALLATIONS

The reliability and life-expectancy of our fans and dampers are second-to-none. Yet, critical installations such as hospitals, hotels etc. may need extra assurance with redundancy.

The redundant mechanical draft system design of the BDC 26 controls two individual parallel systems - a Primary and a Secondary - each with its own draft fan and modulating draft control. The BDC controller monitors both systems and if the Primary system fails, it will switch to the Secondary system and warn the building operator.

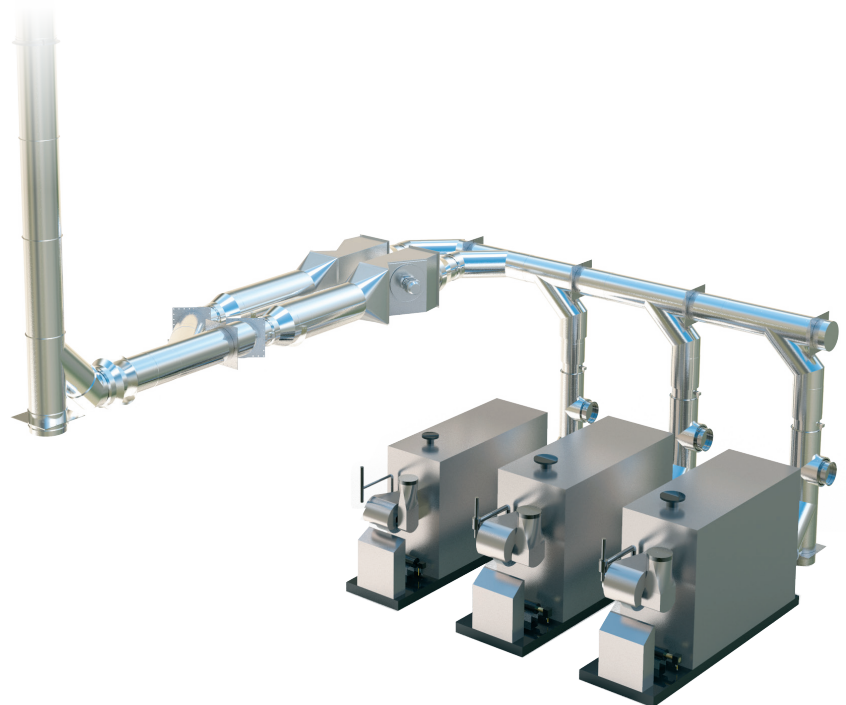

CONTROLS WITH BACNET / MODBUS

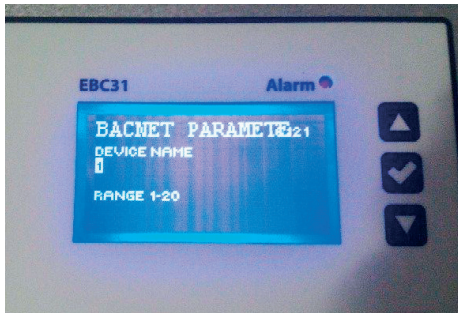

The world is connected, and our draft control systems have standard connectivity through Modbus or BACnet protocols. Or remote access the controllers via a dial-up connection or Wi-Fi via the built-in webserver. This allows for 24-hour monitoring of a mechanical draft system – another example of how we innovate.

COMPLETE CONTROL



PROGRAMMABILITY

Our draft controls are based on real PC-boards with processors. They are also “plug-and-play” to make life easy for the installer and user.

Our controls are pre-programmed, but may still require some parameter adjustments such as the draft setting, alarm delay times, pressure sensor range, uni-directional or bi-directional sensing etc. Easy to do due to the intuitive menu-system. You can also back up your system settings remotely or on a USB. Firmware updates can be installed the same way.

By accessing the controller remotely, you can monitor operation on your computer screen. And not on site in front of the control.

1,400°F TEMPERATURE RATINGS



Our fans and dampers are UL-listed to UL 378 Standard for Draft Equipment for 1400°F (760°C) - the benchmark for Building Heating Appliance Chimney and Industrial Chimneys. Our draft equipment used with these chimneys carry similar temperature ratings.

After all, a 1000°F rated chimney with a 575°F draft fan is just a 575°F rated chimney system.

GRAPHITE GASKETS FOR BETTER SEALS

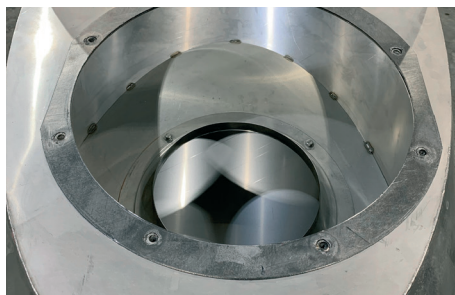

A Graphite gasket is superior to most other sealing materials because it is inert to most gases and liquids, resists high temperatures and can handle high positive and negative pressures. We use graphite for damper shaft seals, fan motor shaft seals, damper and fan joint seals and much more.

No need leaky and messy silicone sealant.

LISTINGS AND APPROVALS

All our products that can be listed or certified to a national standard are either UL listed or ETL listed. We strongly believe in testing standards and are doing our utmost to comply with them in the interest of the user and our own company.

CORROSION RESISTANCE & CONDENSING/NON-CONDENSING APPLICATIONS



Most of our mechanical draft products are round and are used in either low-temperature condensing or high-temperature non-condensing applications.

Our products can handle corrosion and high temperatures – and relatively high pressures. We use a special stainless steel – 316L-PCM - to further improve corrosion resistance. This material withstands and passes corrosion tests required by UL 1738 Standard for Special Gas Vents – which is used for condensing boilers.

Our graphite gaskets are more expensive than silicone sealant, but unlike the silicone it will never leak and it does not need curing during the installation. It can also handle 2000°F air while silicone can only handle 480-550°F!

Our product designs are generally round – shaped like a pipe or chimney. This makes it easy to collect condensate and convey air efficiently. Calculating expansion is easier and more accurately - important for high-temperature applications.



EXPLORE OUR WORK

THE STAR – FRISCO, TX

“THE STAR” IS A 91-ACRE CAMPUS THAT HOSTS THE WORLD TRAINING HEADQUARTERS FOR THE DALLAS COWBOYS.

The Project:

With ENERVEX, AES and Texas Air Systems DFW, they designed and installed a high-efficiency chimney system for its new boilers. The design, which common vents all boilers and water heaters to the outside, uses three chimney exhaust systems in three different sizes and six exhaust fans for chimney systems and intake air.

ENERVEX Solution:

One 30" PowerStack® EPS1 air supply system • Two TDF620 inline Power Venters • Two SFTA18 air supply fans • One 20" PowerStack EPS1 air supply system • One IPVB400 Inline Power Venter • One SFTA18 air supply fan • One 12" PowerStack EPS1 for the fireplace systems.



VENTING THE WORLD'S TALLEST STRUCTURE

BURJ KHALIFA TOWER, DUBAI, UNITED ARAB EMIRATES

The Project:

Formerly Burj Dubai Tower – designed by Skidmore, Owings and Merrill in Chicago.

Mixed-use tower featuring world's first Armani Hotel Dubai and Armani Residences, alongside corporate suites, residences, retail and leisure facilities.

Location: downtown Burj Dubai, a 500-acre mega-development by Emaar Properties.

At 2,716 ft. (828 m), it's the world's tallest structure.

ENERVEX Solution:

- Six demand-controlled inline Mechanical Draft Systems for the building's water heaters and steam boilers.
- Heating appliances are exhausted via six chimney flues, each with an integrated inline Mechanical Draft System.
- Chimney flues mostly running horizontally through building, terminating to the outside via sidewalls and through the ground for aesthetics.
- Systems provide ventilation to the mechanical room by maintaining an air exhaust rate while controlling the chimney flue draft, as well as the combustion air intake.



LITTLE CAESAR'S ARENA IN DETROIT

The Project:

Part of a \$650 million mixed-use development, Little Caesars Arena is Detroit's newest sports and entertainment complex hosting the Detroit Red Wings. They needed to common vent six Cleaver-Brooks Clearfire condensing appliances 150 feet in a 36" Special Gas Vent to the outside through a large parking garage. This, while still providing a perfect draft and the desired boiler efficiency. Reps at Mechanical Resource Group and ENERVEX Michigan teamed up to design a listed, fully integrated commercial venting and draft control system.

ENERVEX Solution:

PowerStack EPS1 Chimney System with six 16" connectors & one 36" common stack • TDF-620 Power Venter inline fan

Six 16" Modulating Overdraft Dampers • Seven EBC30 Modulating Controllers to monitor & maintain pressure



ST. REGIS HOTEL, DUBAI, UAE

The Project:

The St Regis Dubai luxury hotel opened its doors in 2015 on Sheikh Zayed Road at the location of the former Metropolitan Hotel which was the first hotel in Dubai. The St Regis is right next to the Dubai water canal in the Al Habtoor City complex.

They needed to common vent five Cochran Hot Water Boilers 180 feet in a 24" common chimney to the outside through a large parking garage and terminating 100 feet away from the building in the hotel's park. This, while still providing a perfect draft and the desired boiler efficiency.

ENERVEX Solution:

PowerStack EPS1 Chimney System with five 14" connectors & one 24" common stack • TDF-620 Power Venter inline fan • Five 14" ADF Automatic Dampers • EBC30 Modulating Controller to monitor & maintain pressure



LUTHERAN GENERAL HOSPITAL, ILLINOIS

The Project:

Newly constructed US \$201M, eight-story, 192-bed patient care tower designed by OWP/P and CannonDesign.

First hospital in Illinois to achieve LEED. Gold certification and one of only a handful in U.S. with this designation. Long horizontal and vertical chimney sections with many elbows. Sustainability and patient/staff safety were key objectives. Allows boilers to operate at their rated efficiencies.

ENERVEX Solution:

- Two banks of Aerco Benchmark 3.0 boilers with seven and eight boilers, respectively, exhausted by redundant demand-controlled Mechanical Draft Systems.
- Building's mechanical and electrical systems reduced energy use by 21%.
- Supplies critical HVAC system with two redundant systems – one for each bank of boilers.
- Each consists of two ENERVEX Power Venters with modulating over-draft dampers and a redundant control system with redundant VFDs, Modulating Draft Controls, pressure sensor, etc. and redundant logics.

ENERVEX: THE INDUSTRY'S TRUE INNOVATOR

INDUSTRY FIRSTS

ENERVEX is the most innovative supplier of mechanical draft systems in the world. While others are simply adding a façade to existing products, ENERVEX is creating original innovations that have a purpose. Since introducing the industry's first chimney fan in 1958, ENERVEX continues to bring industry-first innovation to the market:

(1991)
MODULATING MECHANICAL DRAFT SYSTEMS

(1995)
MODULATING COMBUSTION AIR SUPPLY SYSTEMS

(2006)
TRUE INLINE MECHANICAL DRAFT FANS

(2011)
FAN-POWERED FLUE GAS ECONOMIZERS

(2013)
INLINE FLUE GAS ECONOMIZER WITH MODULAR HEAT EXCHANGER SYSTEMS

(2015)
ULTRA-ENERGY EFFICIENT, PERMANENT MAGNET MOTORS; STANDARD IN MOST FAN PRODUCTS

(2015)
SINGLE UNIVERSAL CHIMNEY SYSTEMS LISTED FOR VIRTUALLY ALL VENTING APPLICATIONS

(2015)
HIGH-TEMPERATURE, PRESSURE- AND LEAK-RESISTANT GRAPHITE GASKETS FOR SEALING FAN/CHIMNEY JOINTS

ONLY SUPPLIER WITH A 5-YEAR PERFORMANCE & LEAKAGE GUARANTEE

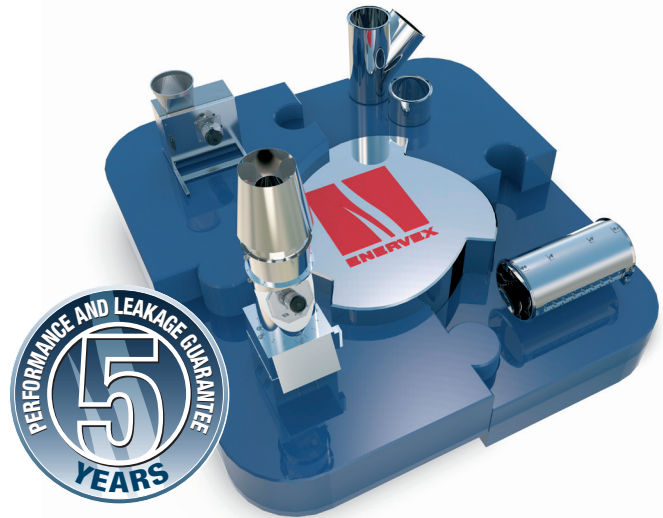

WHY ENERVEX

Every ENERVEX solution is built from the ground up with careful evaluation of the unique cost variables and long-term savings. Through superior manufacturing innovation and decades of experience, we're delivering highest-quality, listed and certified venting solutions that are:

ECONOMICAL. Up to 10% fuel savings & 90% lower energy consumption - plus space, materials & labor savings.

PLUG-AND-PLAY. One-stop design offers seamless installation, flexibility & confidence that everything will fit together.

SUSTAINABLE. Low-energy installations, better indoor air quality; active participant of green building initiatives around the globe.

AESTHETICALLY PLEASING. Smaller footprint & design flexibility; put air louvers/terminations where you want.

SAFE & RELIABLE. Tested, listed and certified materials means no code problems from boiler outlet to chimney termination.

GUARANTEED. One supplier to call for the entire system, backed by the industry's only 110% performance guarantee.

LEARN MORE

Find out how ENERVEX's innovative mechanical draft systems can benefit your next project. Call us or visit ENERVEX.COM now.

ENERVEX Inc.
1685 Bluegrass Lakes
Parkway
Alpharetta, GA 30004
USA

P: 770.587.3238
F: 770.587.4731
T: 800.255.2923
info@enervex.com
www.enervex.com

ENERVEX® 
VENTING DESIGN SOLUTIONS