

ENERVEX VHX-SR VORTEX HEAT RECOVERY CENTER

010.4110.0619 08.21

Installation & Operating Manual

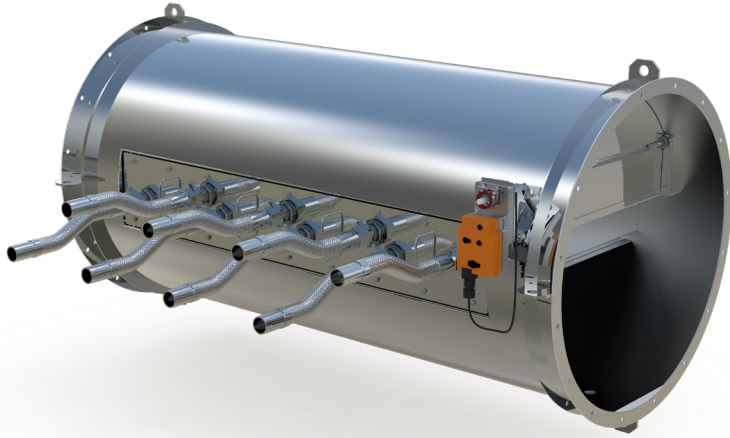

ENERVEX Inc.
1685 Bluegrass Lakes
Parkway
Alpharetta, GA 30004
USA

P: 770.587.3238
F: 770.587.4731
T: 800.255.2923
info@enervex.com
www.enervex.com

ENERVEX[®] 
VENTING DESIGN SOLUTIONS

WARNING

DO NOT OPERATE, SERVICE, OR REPAIR THIS EQUIPMENT UNLESS YOU FULLY UNDERSTAND ALL APPLICABLE SECTIONS OF THIS MANUAL.

DO NOT ALLOW OTHERS TO OPERATE, SERVICE, OR REPAIR THIS EQUIPMENT UNLESS THEY FULLY UNDERSTAND ALL APPLICABLE SECTIONS OF THIS MANUAL.

FAILURE TO FOLLOW ALL APPLICABLE WARNINGS AND INSTRUCTIONS MAY RESULT IN SEVERE PERSONAL INJURY OR DEATH.

TO: Owners, Operators and/or Maintenance Personnel

This operating manual presents information that will help to properly operate and care for the equipment. Study its contents carefully. The unit will provide good service and continued operation if proper operating and maintenance instructions are followed. No attempt should be made to operate the unit until the principles of operation and all of the components are thoroughly understood. Failure to follow all applicable instructions and warnings may result in severe personal injury or death.

It is the responsibility of the owner to train and advise not only his or her personnel, but the contractors' personnel who are servicing, repairing or operating the equipment, in all safety aspects.

ENERVEX equipment is designed and engineered to give long life and excellent service on the job. The electrical and mechanical devices supplied as part of the unit were chosen because of their known ability to perform; however, proper operating techniques and maintenance procedures must be followed at all times. Although these components afford a high degree of protection and safety, operation of equipment is not to be considered free from all dangers and hazards inherent in handling and firing of fuel.

Any "automatic" features included in the design do not relieve the attendant of any responsibility. Such features merely free him of certain repetitive chores and give him more time to devote to the proper upkeep of equipment.

It is solely the operator's responsibility to properly operate and maintain the equipment. No amount of written instructions can replace intelligent thinking and reasoning and this manual is not intended to relieve the operating personnel of the responsibility for proper operation. On the other hand, a thorough understanding of this manual is required before attempting to operate, maintain, service, or repair this equipment.

Because of state, local, or other applicable codes, there are a variety of electric controls and safety devices which vary considerably from one boiler to another. This manual contains information designed to show how a basic burner operates.

Operating controls will normally function for long periods of time and we have found that some operators become lax in their daily or monthly testing, assuming that normal operation will continue indefinitely. Malfunctions of controls lead to uneconomical operation and damage and, in most cases, these conditions can be traced directly to carelessness and deficiencies in testing and maintenance.

It is recommended that a boiler room log or record be maintained. Recording of daily, weekly, monthly and yearly maintenance activities and recording of any unusual operation will serve as a valuable guide to any necessary investigation. Most instances of major boiler damage are the result of operation with low water. We cannot emphasize too strongly the need for the operator to periodically check his low water controls and to follow good maintenance and testing practices. Cross-connecting piping to low water devices must be internally inspected periodically to guard against any stoppages which could obstruct the free flow of water to the low water devices. Float bowls of these controls must be inspected frequently to check for the presence of foreign substances that would impede float ball movement.

The waterside condition of the pressure vessel is of extreme importance. Waterside surfaces should be inspected frequently to check for the presence of any mud, sludge, scale or corrosion.

It is essential to obtain the services of a qualified water treating company or a water consultant to recommend the proper boiler water treating practices.

The operation of this equipment by the owner and his or her operating personnel must comply with all requirements or regulations of his insurance company and/or other authority having jurisdiction. In the event of any conflict or inconsistency between such requirements and the warnings or instructions contained herein, please contact ENERVEX before proceeding.

1. PRODUCT INFORMATION		10. ECONOMIZER CONTROLS (HRC 80)	
1.1 Function.....	4	4.1 General.....	22
1.2 Components.....	5		
1.3 Shipping	5		
1.4 Warranty	5		
2. SPECIFICATIONS AND DIMENSIONS			
2.1 Dimensions and Capacities.....	6		
3. PRE-INSTALLATION INFORMATION.....	7		
4. MECHANICAL INSTALLATION			
4.1 General.....	8		
4.2 Positioning.....	8		
4.3 Vertical Installation.....	9		
4.4 Horizontal Installation	9		
4.5 Connection to Chimney (U-Band).....	9		
4.6 Connection to Chimney (Bolted Flange).....	10		
4.7 Modulating Bypass with Flow Control	10		
5. PLUMBING INSTALLATION			
5.1 General.....	11		
5.2 Connecting Piping	11		
5.3 Mounting of Temperature Sensor	12		
5.4 Safety Relief Valves.....	12		
5.5 Mouting of Flow Meters (if applicable).....	12		
5.6 Special Installation Considerations.....	12		
6. ELECTRICAL INSTALLATION			
6.1 General.....	14		
6.2 Modulating Bypass Damper.....	14		
7. STARTUP AND CONFIGURATION			
7.1 General.....	15		
8. MAINTENANCE AND TROUBLESHOOTING			
8.1 General.....	16		
8.2 Removal of Heat Modules.....	16		
8.3 Maintenance.....	16		
8.4 Cleaning.....	16		
9. APPLICATION EXAMPLES			
9.1 Preheating Boiler Return Water	18		
9.2 Preheating Circulating Feed Water	18		
9.3 Preheating Boiler Make Up Water	19		
9.4 Preheating Steam Boiler Feed Water.....	19		
9.5 Circulating Make Up Water Heating	20		
9.6 Condensate Return Heating	20		
9.7 Calorifier Heating Loops	21		
9.8 Process Water Heating.....	21		

1. PRODUCT INFORMATION

1.1 FUNCTION

The VHX-SR, Vortex Heat Recovery Center, is a unique and highly efficient economizer system with a built-in bypass.

It is a fully packaged light weight product with a round configuration for ease of installation. The all 316L stainless steel construction allows it to be used for both condensing and non-condensing applications without any modifications.

It is extremely compact compared to traditional economizers as it utilizes a modular design with one or more heat modules that each have supply and return connections representing individual liquid circuits. Individual circuits can be connected to one or more common headers in accordance with the specific application.

The modular design allows the economizer to be used for multiple applications at the same time: one module can be used for preheating of feedwater, one module for domestic hot water, and one module for direct pool heating etc.

The unique economizer design creates a turbulent flow across the module surface, thus maximizing heat transfer. The modules are designed to handle asymmetric volume flows with exceptionally high performance and are mounted in individual slots - an easily serviceable configuration.

A modulating, single-blade or multi-blade (depending on model size) damper design provides bypass capabilities for use with dual fuel applications, and also prevents overheating of the heat modules.

In most applications, the economizer is fully designed and packaged with an automated mechanical draft system capable of optimizing the exhaust rate of the appliance to completely stabilize the appliance efficiency combustion as well as to assure a proper and constant draft for the appliance. This allows a single economizer to serve multiple boilers no matter whether they are of atmospheric, fan-assisted or forced draft design.

The VHX-SR is virtually maintenance free, having no moving parts except the internal gas bypass assembly.

The performance of this type of exchanger is ultimately dependent upon the dynamic conditions of temperature, pressure and massflow available on both the liquid and gas side.

The custom transitions offered fit most commercial prefabricated chimney systems.

The VHX-SR Heat Recovery Module should only be used with appliances operating on Natural Gas, LP-Gas/Butane or low sulfur fuel oil (#2 through #6). In some exhaust applications containing debris etc., cleaning may be required periodically.

1.2 COMPONENTS

The VHX-SR Heat Recovery Center can be supplied in several configurations with single or multiple heating modules. A modulating bypass damper controlled by a modulating damper actuator is standard for all. The major components are shown in Fig 1.

Components such as headers, pressure relief valves, temperatures sensors, flowmeters and controls are optional but can be supplied by ENERVEX.

1.3 SHIPPING

ENERVEX inspects all equipment prior to shipment and cannot be held responsible for damage caused in transit. In addition, all electrical devices are also thoroughly tested to assure that they operate according to design specifications.

All economizers are shipped via common carrier. Take care to inspect the economizer when you receive it and make any claims for damages immediately to the carrier within the allowable time limit.

The VHX-SR product line units are shipped on pallets. To remove the economizer, first position the unit, while either still in the shipping container or on the skid, as close to the installation site as possible. Then attach a lifting hoist to all the lifting lugs located on the top of the housing or on the side.

If other components are shipped, these will appear as separate items on the shipping packing list.

If there are any questions during the removal and installation of the exchanger please do not hesitate to contact your authorized ENERVEX representative for suggestions.

1.4 WARRANTY

2-Year Factory Warranty. Complete warranty conditions are available from ENERVEX, Inc.

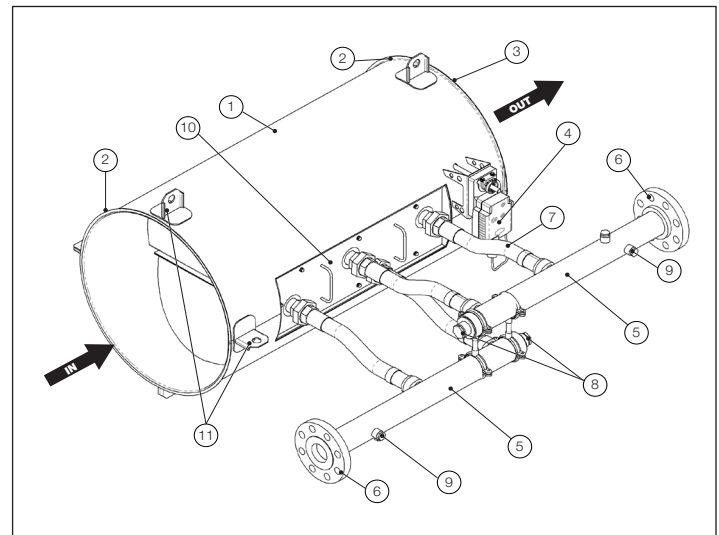

Fig 1

1. Economizer housing
2. Mounting Flanges (1/2" flange or bolt flange)
3. Damper (not pictured)
4. Modulating actuator
5. Header (optional)
6. Connection flange
7. Flexible connectors
8. Connection for pressure relief valve
9. Connection for water temperature sensor
10. Cover for heat module chamber
11. Lifting Lug

2. SPECIFICATIONS AND DIMENSIONS

2.1 DIMENSIONS AND CAPACITIES

Specifications

Single Row Models	VHX 100-10SR	VHX 250-10SR	VHX 400-10SR	VHX 800-20SR	VHX 1200-30SR	VHX 1600-40SR	VHX 2400-50SR	VHX 3200-60SR
Housing Material	ASTM 316L / 1.4404							
Heat Exchanger Material	ASTM 316L / 1.4404							
No. Heat Modules	1	1	1	2	3	4	5	6
Heat Module Type	Cross 30-60	Cross 30-100	Cross 30-140	Cross 30 - 140	Cross 30 - 140	Cross 30 - 140	Cross 30 - 140	Cross 30 - 140
Heat Exchanger Plate Surface Area Ft ²	45	74	104	208	312	416	520	624
Operating Pressure Max PSI	230							
Water Connection NPT ¹⁾	1" NPT	1 1/4" NPT MALE						
Weight (Dry) lbs/kg	57 / 26	77 / 35	97 / 44	183 / 83	302 / 137	423 / 192	577 / 262	736 / 334
Weight (Wet) lbs/kg	65 / 30	80 / 36	115 / 52	220 / 100	357 / 162	486 / 225	668 / 303	845 / 384
Length in/mm	24.0 / 610	24.0 / 610	26.0 / 660	42.0 / 1067	50.0 / 1270	64.0 / 1626	78.0 / 1981	90.0 / 2286
Dimensions ID in/mm	12.0 / 305	16.0 / 406	20.0 / 508	22.0 / 559	26.0 / 660	30.0 / 762	36.0 / 914	42.0 / 1067
Flange OD in/mm	13.0 / 329	17.0 / 430	21.0 / 532	23.0 / 584	29.0 / 737	33.0 / 838	39.0 / 991	45.0 / 1143
Flange	1/2" U-Band Flange				16 Bolt Hole Flange			

¹⁾ NPT adaptors available from ENERVEX, Inc.

Larger sizes available upon request; contact ENERVEX, Inc. with specifications.

3. PRE-INSTALLATION INFORMATION

The VHX-SR Heat Recovery Center is used with a liquid in the circuit with connections and a gas on the open side. The heat exchanger must operate in line with approved design parameters: temperatures, pressures and flow rates.

Liquid side

Typical medias are ethylene/propylene glycol, thermal oil, and water. It is important that the liquid is of good quality without contamination or corrosive substances. The medias should not contain particles or any other undissolved matter, we recommend that a strainer with a size of 16-20 mesh (number of openings per inch) is installed before the fluid inlet. The particles could otherwise block the channels, causing bad performance, increased pressure drop and the risk of boiling.

Systems with water or another evaporating liquid must be equipped with the necessary bleed valve mounted in a position higher than the heat exchanger. Air/gas inside the liquid channels will reduce heat transfer and water circulation, which also could cause boiling.

The liquid flow must be constant and with sufficient pressure to keep its evaporating/boiling temperature above the plate temperature. Local evaporation/boiling will adversely affect heat transfer and water circulation, and may lead to a risk of serious damage to the heat exchanger.

NOTE: The pressure at the coolant outlet must be high enough to avoid boiling.

The VHX heat modules must always have the cooling fluid circulating fully before the hot gas enters the heat exchanger.

The coolant must NEVER be allowed to freeze.

Never expose the VHX Heat Modules to excessive liquid pulsations (i.e. cyclic pressure or temperature changes).

Gas side

The gas media should not be corrosive to the heat modules. The gas flow must be started after, or simultaneously to, the start of the liquid flow. If the liquid flow is interrupted, the gas must be stopped or caused to bypass the VHX heat modules to avoid boiling on the liquid side.

The VHX-SR Heat Recovery Center must not be operated in such a manner that stagnant condensate is allowed to accumulate. Never expose the Cross heat exchanger to excessive gas pulsations (i.e. cyclic pressure or temperature changes).

The VHX-SR Heat Recovery Center must NEVER be operated without a coolant flow.

4. MECHANICAL INSTALLATION

4.1 GENERAL

**WARNING**

Failure to install, maintain and/or operate the VHX-SR Heat Recovery Center in accordance with the manufacturer's instructions may result in conditions which can produce bodily injury and property damage.

The VHX-SR must be installed by a qualified installer in accordance with these instructions and all local codes, or in their absence, with the latest edition of The National Fuel Gas Code (NFPA54/ANSI223.1), NFPA 211, NFPA 31 or Canada CAN/CSA-B149.1-05 National Gas and Propane Installation Code when applicable. The VHX must be mounted so the clearance to combustibles is at least 18 inches.

Preferably, the VHX should be installed as close to the heating appliance as possible — vertically or horizontally in the breeching. It can also be installed near the termination or on a roof. In addition, it can be used for sidewall vented applications where it discharges through a wall. A condensate drain is provided with the VHX to be installed by the user.

The VHX is for indoor and outdoor installation. If installed outdoors, steps must be taken to prevent freezing of water in the VHX housing and pipes (see Section 4.3). The vent pipe must be installed and supported according to the chimney manufacturer's instructions and/or in accordance with NFPA54, NFPA211 and Canada CAN/CSA-B149.1-05.

4.2 POSITIONING

Consult "2. Specifications" for specific weights and dimensions to ensure a well designed and safe installation when either hanging or supporting the exchanger. The exchanger is shipped ready to be mounted in the vertical or horizontal position. Make sure to check the actual number of lugs and their positions on the spec drawings before planning the installation.

For existing retrofit installations, ensure that the combustion source has been turned off and has cooled. A condensate drain connection is provided at the bottom of the unit. Header manifold inlet/outlet connections for water supply and return are optional. For retrofit installations the economizer is installed in line with the existing exhaust stack or duct unless otherwise noted

Generally a section of the exhaust stack is removed to accommodate the insertion of the economizer. The remaining portion of the exhaust stack above the cut should not exceed a static load of 500 lbs. or exert any moments on the outlet flange, and must be adequately supported.

In some cases the economizer may be placed directly on top

of the combustion source, in effect forming the first section of the exhaust duct, with the existing exhaust stack lifted or cut to accommodate the economizer.

NOTE: Structural integrity of the building should be verified (by others) prior to installing an economizer by suspending from the ceiling.

4.3 VERTICAL INSTALLATION

For vertical flow units it is recommended that the unit be completely supported either by a floor support structure or by threaded rods from the ceiling (design and supply of support by others).

In no case should the static load on the economizer inlet or outlet flange exceed 500 pounds. In no case should any moment be applied to the economizer inlet or outlet. Lifting lugs are placed on top of the economizer and on each side. Actual number depends on the model, please refer to the specification drawing for the specific VHX model.

Apply expansion joints (supplied by others) as required by the installation to ensure that no outside forces from thermal expansion to either the exhaust gas connections or to the piping will be permitted.

4.4 HORIZONTAL INSTALLATION

For horizontal flow units the economizer must be suspended from the ceiling as permitted or set in place on a structural support (designed by others) as permitted.

Lifting lugs are placed on top of the economizer and on each side. Actual number depends on the model, please refer to the specification drawing for the specific VHX model.

Structural integrity of the building should be verified (by others) prior to installing an economizer by suspending from the ceiling. Apply expansion joints (supplied by others) as required by the installation to ensure that no outside forces from thermal expansion to either the exhaust gas connections or to the piping will be permitted.

4.5 CONNECTION TO THE CHIMNEY (U-BAND)

Exhaust connections are generally mated with optional mating flanges and/or stack transitions.

Connection to the economizer flange is either by a gasket provided by others or applying a continuous 1/3 inch bead of the appropriate sealant around both the economizer flange and the corresponding chimney flange adaptor.

The chimney flange adaptor is then connected to the economizer flange. Please note that neither the gasket nor the sealant is provided with this component. Ensure that the economizer is level before final positioning.

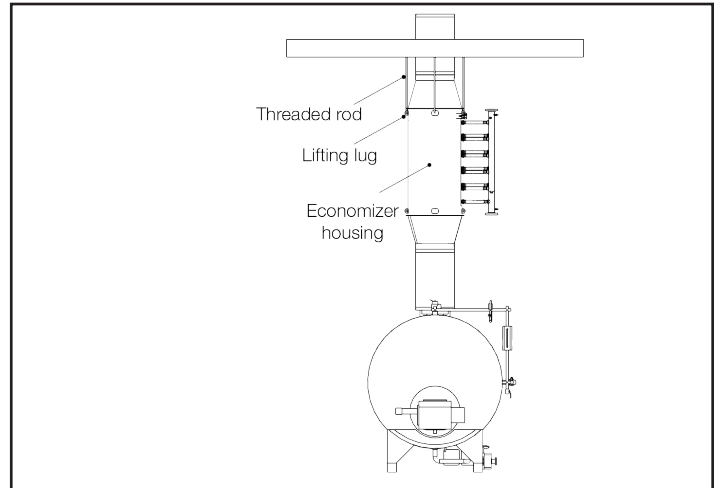

Fig 2

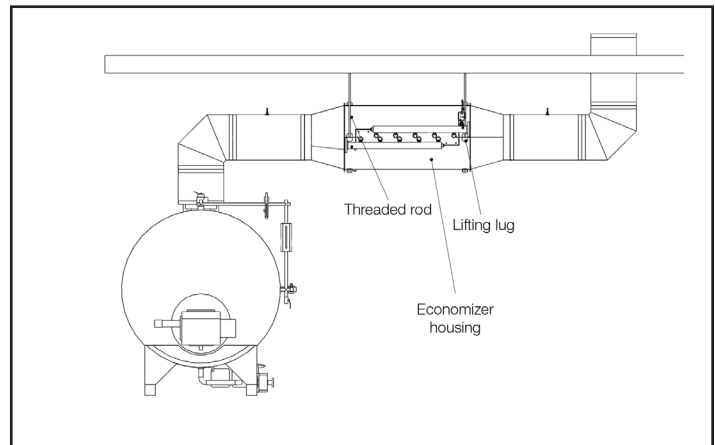

Fig 3

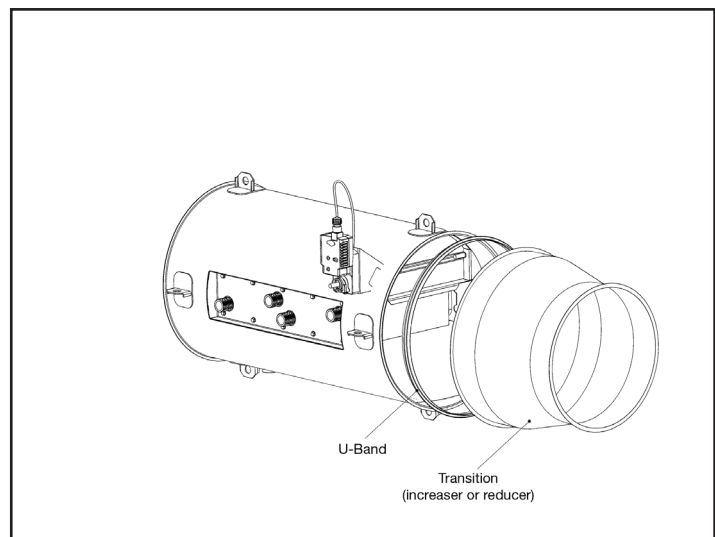

Fig 4

4.6 CONNECTION TO THE CHIMNEY (BOLTED FLANGE)

Exhaust connections are generally mated with optional mating flanges and/or stack transitions.

Connection to the economizer flange is either by a gasket provided by others or applying a continuous 1/3 inch bead of the appropriate sealant around both the economizer flange and the corresponding chimney flange adaptor.

The chimney flange adaptor is then bolted to the economizer flange. Please note that neither the gasket nor the required nuts and bolts are provided with this component. Ensure that the economizer is level before final bolting into position.

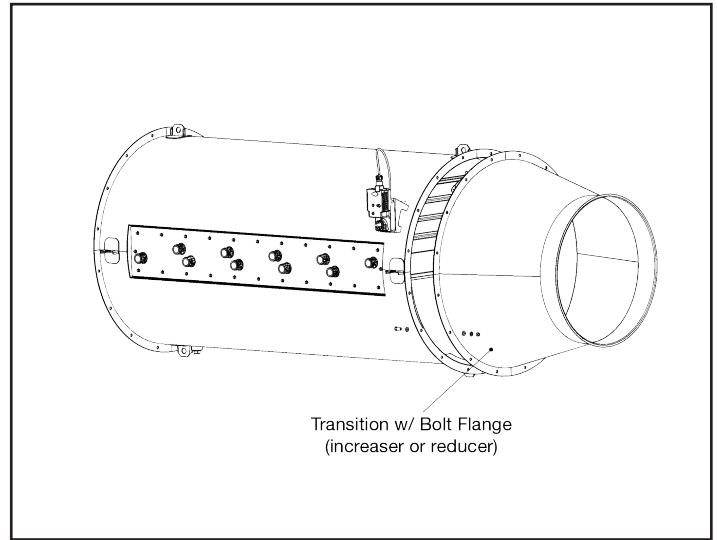

Fig 5

4.6 MODULATING BYPASS WITH FLOW CONTROL

The VHX-SR is equipped with a modulating bypass damper and flow control system.

Fig. 6 shows the inlet of the VHX-SR and the damper in "open" and "closed" positions.

The exhaust flow enters through the top part of the housing, where it is forced down through the heat module(s) as long as the damper is closed (default position).

In the event the system set temperature has been reached, the damper will begin to open and reduce the flow through the heat module(s), which will provide a a reduction in heat recovery. Eventually, if the reduction is inadequate, the damper will open completely which will make the exhaust flow bypass the heat module(s).

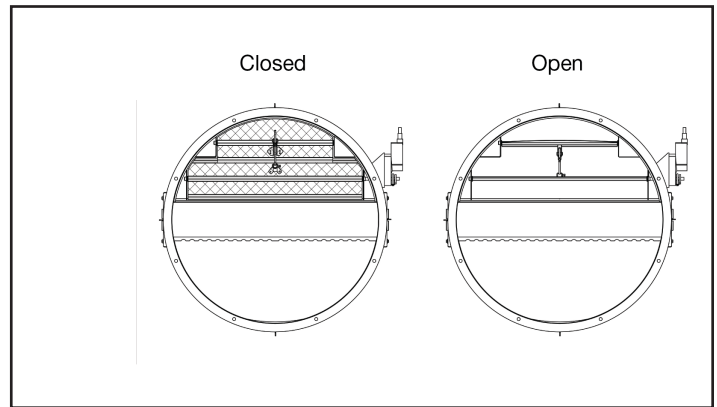

Fig 6

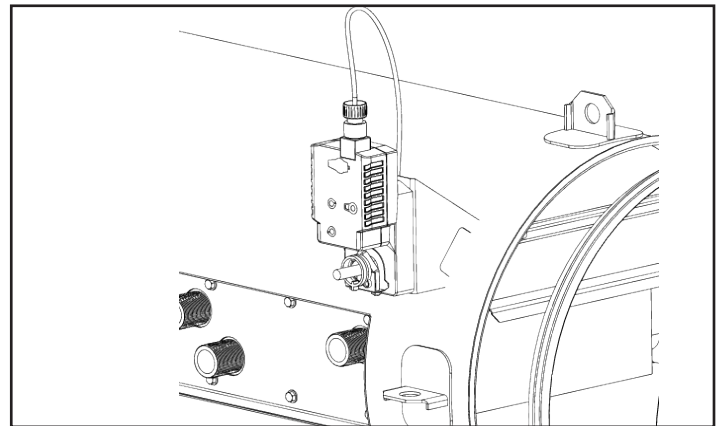

Fig 7

5. PLUMBING

5.1 GENERAL

It is not within the scope of this manual to provide specific plumbing installation instructions as the installation should follow the design specifications of the design engineer, architect, or contractor. However, measures must be taken to prevent the water from stagnating within the economizer while the boiler(s) are in operation. Also, the water side of the economizer must be kept free of grease and other foreign material which can shorten the life of the economizer and possibly interfere with the operation of controls and safety devices. Proper feedwater treatment is a major factor in preventing economizer failure.

Only low sulfur fuels should be used with the VHX-SR. If fuels other than natural gas are used, there is a risk of "cold end corrosion" when the entering water temperature falls enough to cause condensation of the flue gases so verify the feasibility of the application with the design engineer prior to installation.

Generally, schedule 40 steel pipe is used in the piping installation. In some applications other piping material may be needed. Consider the type of liquid, operating pressures and temperatures, and any corrosive elements in the liquid or in the atmosphere when determining the best piping material for your installation. The use of valves is recommended where isolation might be required. Non-ferritic piping is recommended if using non-deaerated water.

5.2 CONNECTING PIPING

Actual piping depends on how the heating modules are configured. Water should flow counter flow to the exhaust. If the heat modules are connected to a common header, supply and return liquid pipes must be connected directly to the common header. This is shown in Fig. 8. Balancing valves should be installed in order to ensure that the flow is equally distributed.

If the VHX-SR is used for multiple applications, e.g. one heat module is used for domestic water while the other is used for boiler feed-water, each application must be connected directly to the supply and return connections on the heat module. See Fig. 9.

Liquid connections are connected with NPT threaded fittings. The maximum allowable connection loads given in Fig 10 are valid for low cycle fatigue. If high cycle fatigue is involved, a special analysis should be carried out

Liquid piping should include shut-off, drain and bypass valve piping in the event the exchanger is required to be isolated.

Drain piping should include valves of dependable manufacture in order to further reduce the possibility of an undetected leak.

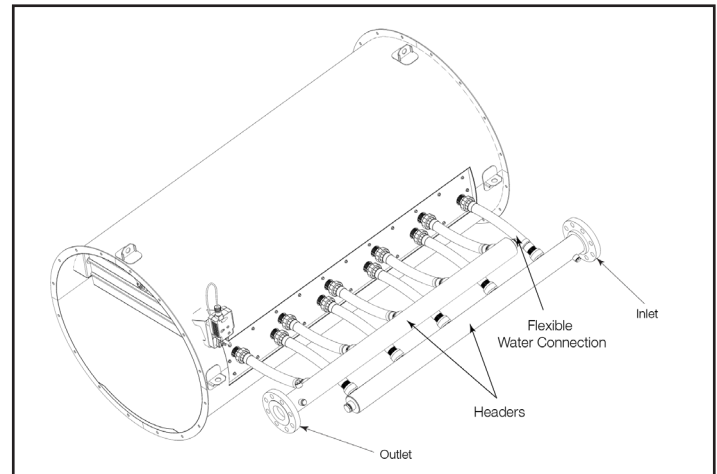

Fig 8

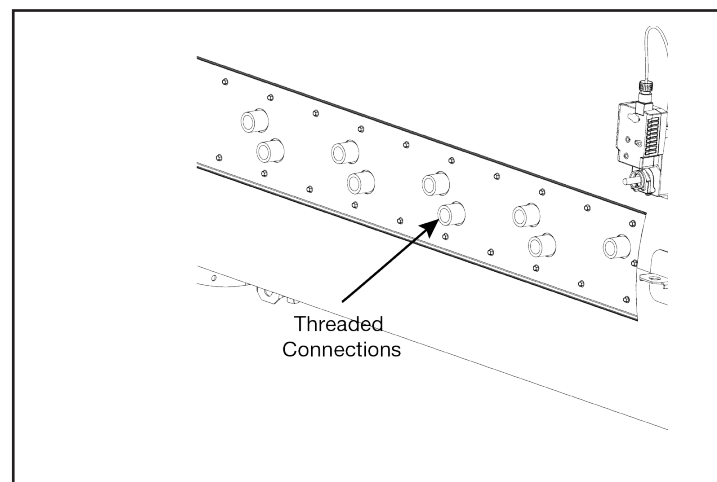

Fig 9

	Max. Bending Torque	Torque Moment
Connections	20 Nm	70 Nm

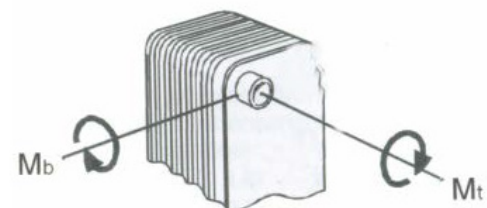

Fig 10

The installation of a vent valve at the highest point in the piping system is recommended in order to purge air out especially during initial start up.

Safety relief valves, as required, should be located at the exchanger and piped separately and safely to the drain.

5.3 MOUNTING OF TEMPERATURE SENSORS

There are four temperature sensors. Two flue gas high temperature sensors (PT1000) and two Hi-Temp water sensors (HT-NTC).

Install the flue gas temperature sensors before and after the economizer. The minimum recommended distance is three times the diameter (3xID) of the flue. See Fig 11.

The installation order and parts involved is shown in Fig 12.

Temperature sensors are installed on the water lines inlet and outlet of the heat exchanger. The water temperature sensors should be installed as practically close as possible to the heat exchanger. See Fig 13.

NOTE: Ensure that the water temperature sensor is fully inserted into the socket after the electricians have finished running the wires. If it is not fully inserted the system will not read the correct temperature and will not be able to react appropriately.

5.4 SAFETY RELIEF VALVES

A Safety Relief Valve(s) is required for every installation. In a system with headers, they must be installed according to Fig. 14

NOTE: The safety relief valves must be located between any isolation valves and the VHX-SR and within close proximity of the heat module e.g. in the common header. Liquid piping to and from the heat modules should allow the heat modules to be filled at all times especially when flow could stop.

5.5 MOUNTING OF FLOWMETERS (IF APPLICABLE)

A flowmeter is an optional, but highly recommended accessory. There are multiple models available depending on flow and pipe size. The Flowmeter should be installed at the inlet of the heat exchanger. Please refer to the Installation Manual for HRC 80 Heat Exchanger Controller.

5.5 SPECIAL INSTALLATION CONSIDERATIONS

The VHX-SR economizer may be installed inside or outside with appropriate drain piping installed for shutdown periods. If there is a remote chance the temperatures outside might fall below freezing it is recommended that care be taken to avoid potentially freezing the heat transfer core.

A condensate drain connection is provided in the bottom for all economizers and should be piped to a floor drain using a water trap and neutralizer to prevent the escape of flue gases. Please note the submittal drawing or consult ENERVEX regarding location of the economizer condensate drain.

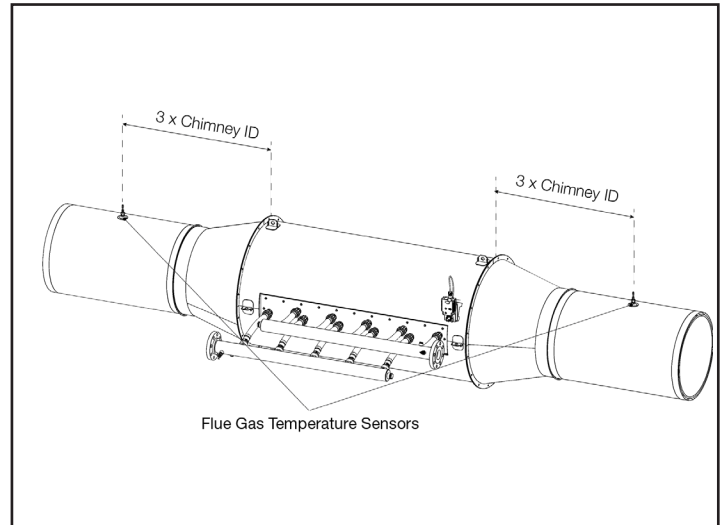

Fig 11

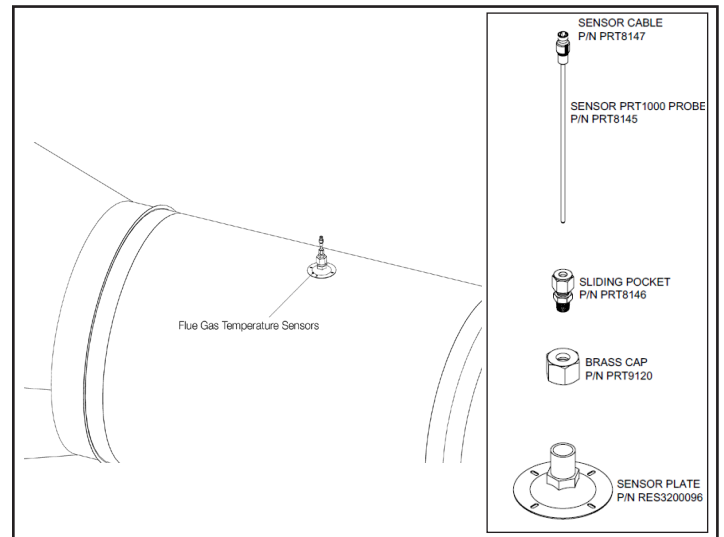

Fig 12

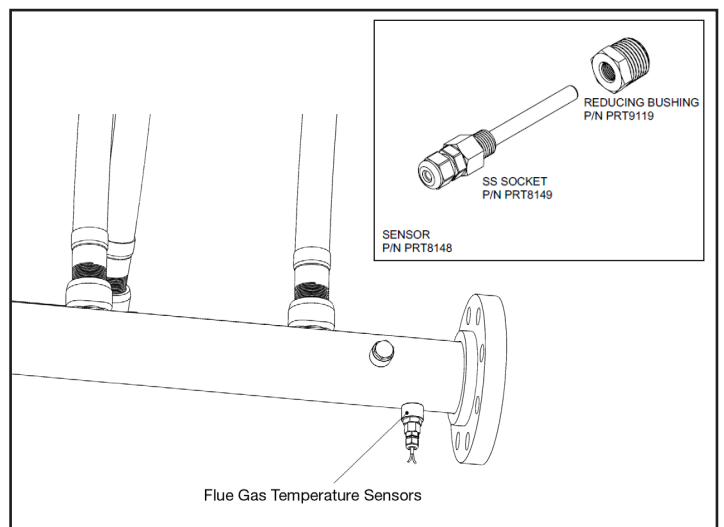

Fig 13

Freeze protection concerns: During a system shutdown where combustion halts for an extended period of time (other than normal cycling), cold air will travel back down the stack and exhaust breechings, through the economizer and into the combustion source. If the cold air is below freezing, it could freeze the plates and cause a rupture, ultimately destroying the economizer. For potential freezing applications where the water flow might stop, a manual system shut down routine should be incorporated. It is not recommended to use solenoid type drain valves for auto draining in subzero environments unless absolutely necessary.

Do not insulate the economizer where factory insulation has already been applied or damage to the exchanger can occur. Insulate piping and exhaust ducting as required.

Ensure that no liquid connections interfere with the opening of recovery unit trays. Economizer relief valves shall not have set pressure ratings higher than the rated pressure of the heat modules. Liquid storage tank relief valves shall not have discharge pressure ratings higher than the rated pressure of the storage tank. To avoid safety valve leakage, ensure that safety valve set pressure is sufficiently higher than dead head pressure of the feed pump.

It is recommended that the pipe and circulating tank (if included) be insulated to reduce heat loss.

If existing conditions may subject the heat modules to internal scale build up, pressure gauges (furnished by others) should be installed on the liquid inlet and outlet sides of the economizer. This will enable monitoring of liquid flow restriction. Capped tees, one on the liquid inlet side and one on the liquid outlet side, incorporated into the piping installation may allow a descaling solution to be used with the economizer in place. Consult the factory for suitable descaling solutions.

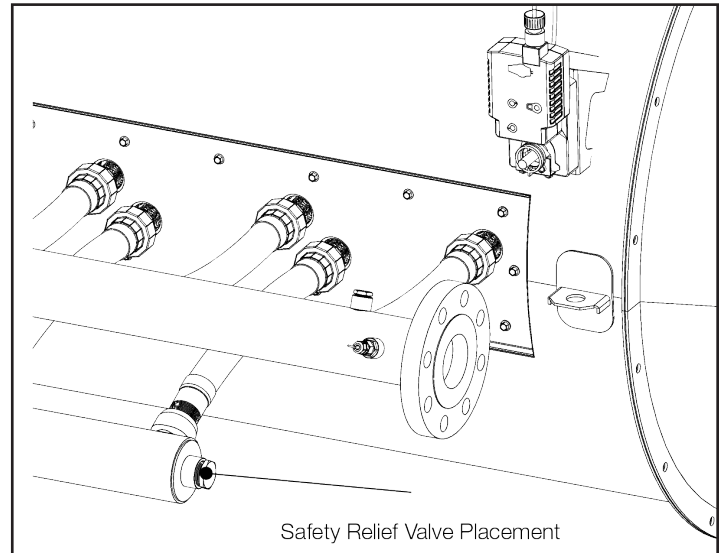



Fig 14

6. ELECTRICAL INSTALLATION

6.1 GENERAL



DANGER

Turn off electrical power before servicing. Contact with live electric components can cause shock or death.



NOTICE

If any of the original wire supplied with the system must be replaced, use similar wire of the same temperature rating. Otherwise, insulation may melt or degrade, exposing bare wire.

All wiring must be in compliance with the local codes, or, in their absence, the National Electric Code, NFPA70. All wiring should be appropriate Class 1 wiring as follows: installed in rigid metal conduit, intermediate metal conduit, rigid non-metallic conduit, electrical metallic tubing, or be otherwise suitably protected from physical damage.

6.2 MODULATING BYPASS DAMPER

The only electrical part of the VHX-SR is the actuator serving the Modulating Bypass Damper. The actuator can be controlled by a 0-10VDC signal either from an ENERVEX HRC80 or from a third-party supplied controller.

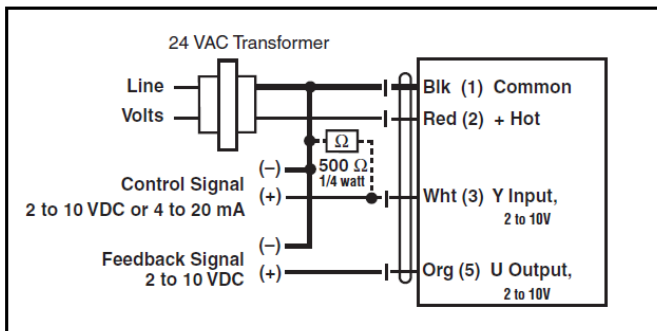

2 to 10 VDC

7. STARTUP AND CONFIGURATION

7.1 GENERAL

During the initial startup and before combustion heat can be applied to the exchanger, ensure that liquid is flowing through the economizer.

NOTE: ENERVEX recommends that liquid is flowing through the economizer at all times to avoid damage to the heat module(s) from stack exhaust overheat. Upon cold startup of a full boiler, provisions must be made to ensure water flow through the VHX-SR. Assure sufficient flow to prevent any unwarranted temperature and pressure buildup within the liquid side of the heat module. When the boiler reaches the operating steam pressure of the system and begins to take on feedwater, normal operation can resume.

! Important

If liquid is introduced into a hot exchanger, severe damage can result and will void any warranty. Contact ENERVEX for applications where the exchanger is requested to run dry.

If the final exhaust temperatures are too low, pressure drop across the economizer is too high, or if the desired water temperature is exceeded, adjust the gas bypass damper to attain the desired objective.

While the exchanger is in a clean, like-new condition, note and record the following at a specified condition:

- Liquid inlet and outlet temperatures
- Exhaust gas inlet and outlet temperatures
- Pressure gauge reading (if applicable)

This information will provide a point of reference in the event of a future fouling condition.

MONITORING PERFORMANCE

It is recommended to inspect the core or coil if the performance (liquid temperatures leaving and Btu/hr. recovery) begins to decrease. A good practice of maintenance is to keep a performance schedule starting when the economizer is installed to compare with any future changes.

Operational start-up

Make sure that:

If there is a risk of high temperatures, the unit is insulated as a precaution to avoid injuries.

Installation has been carried out according to the flow schedule / drawing and recommendations.

- Connections are tight.
- No vibrations or pulsations are transferred to the Cross 30.
- The liquid side is filled and deaerated.
- The flow rate and pressure on the liquid side are correct before gas flow is started.

- The temperature and flow rates are according to specification.
- There is appropriate drainage to deal with any condensation.

NOTE: Ensure that the combustion source is off and is cool, and the economizer is cool before attempting to inspect or clean the coil(s).

8. MAINTENANCE AND TROUBLESHOOTING

8.1 GENERAL

The VHX-SR economizer is virtually maintenance free. Nevertheless, periodic inspections will ensure trouble-free operation and long equipment life.

A routine physical inspection of the heat transfer core area will depend on the conditions of temperature and the quality of combustion within the flue gas stream.

NOTE: Ensure that the combustion source is off and is cool, and that the economizer is cool before attempting to inspect or clean the heat exchanger.

With clean exhaust conditions, physical inspection will be minimal if proper combustion at the heat source is maintained. The inspection and maintenance procedure can be performed without dismantling any of the piping or the stack connections.

8.2 REMOVAL OF HEAT MODULES

The heat module(s) is installed in a slot.

Before removing the module, drain the system of water. Follow this procedure (See Fig 15):

1. To remove module, disconnect flexible piping from the the heat module.
2. Remove all bolts from the cover plate.
3. Remove the cover plate, which gives full access to the heat modules.
4. Slide modules out individually.

8.3 MAINTENANCE

The module has no moving parts or electrical components.

The following should be inspected regularly:

- Operational design conditions for the system being maintained, and meeting the calculated / design values (leaving temp., pressure drop).
- Increased pressure drop and decreased thermal efficiency over time are signs of possible fouling.
- Connections for tightness.
- Gas channels for accumulated dirt.
- Plate surfaces for corrosion.
- Seal and gaskets.
- External components such as valves, dampers and controls.

8.4 CLEANING

The normally high degree of turbulence in the module gives a self-cleaning effect in the liquid channels, which reduces fouling and the build-up of contamination, which can seriously reduce heat transfer capacity and increase pressure drop.

Cleaning liquid side

In some applications, the fouling tendency can be very high, for example with extremely hard water at high temperatures.

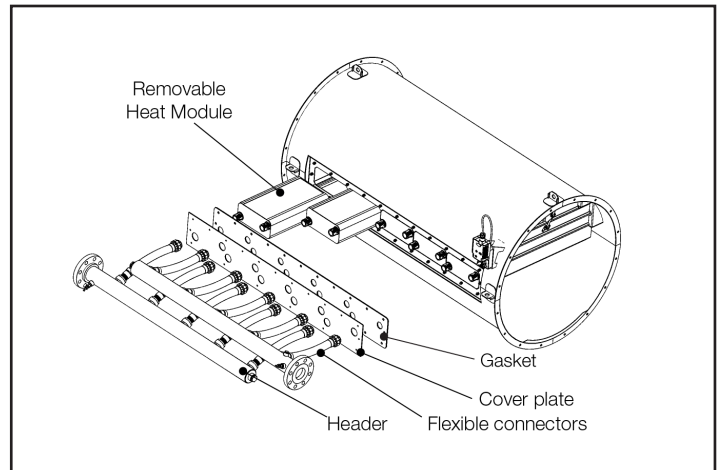

Fig 15

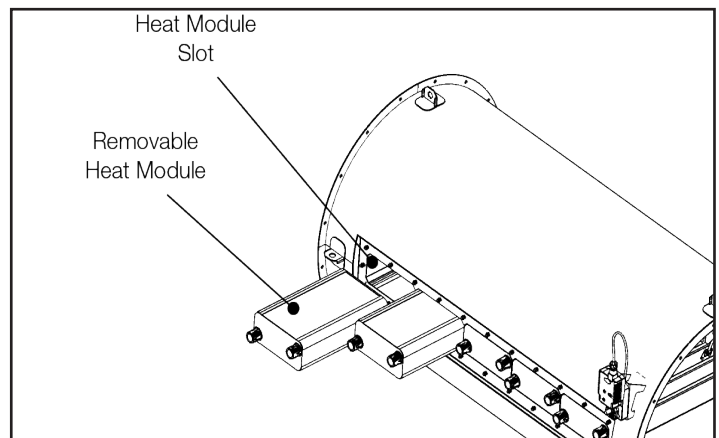

Fig 16

In such cases, the module can always be cleaned by:

- Circulating a cleaning liquid (CIP – Cleaning In Place).
- A solution of 5% phosphoric acid or 5% oxalic acid in water is recommended to chemically clean the channels.
- The flow rate of the cleaning liquid should be greater than the design liquid flow, and the flow should be in the opposite direction through the heat exchanger relative to the flow in normal operation.

ATTENTION: After cleaning, it is very important to flush the heat exchanger thoroughly with clean water before start-up.

Cleaning gas side

Heavy condensation can have a self-cleaning effect, washing the Cross and reducing dirt build-up on the gas side. The module has open gas channels at both ends that can be checked visually. For dry dirt such as carbon, ashes or dust, most of the dirt sticks to the inlet surface. Cleaning with compressed air or high-pressure water up to 200 bar is normally effective. Exhausts from diesel, vegetable oils or biogas combustion may require regular cleaning.

For greasy dirt such as oil, a suitable cleaning liquid is recommended. When using cleaning liquid it is important to flush the module thoroughly with clean water before start-up.

Storage

Some users store spare modules that are used to replace dirty modules to reduce downtime.

The module must always be stored in a dry and protective environment. The temperature should not be below 35°F (1°C) and not above 120°F (50°C) for extended periods of time (4 weeks or more).

During long operational stand-by periods, the system should be inspected for contamination on the liquid and gas sides. If necessary, clean the module according to the cleaning instructions.

Liquid sides containing water should always be drained.

9. APPLICATION EXAMPLES

9.1 PREHEATING BOILER RETURN WATER

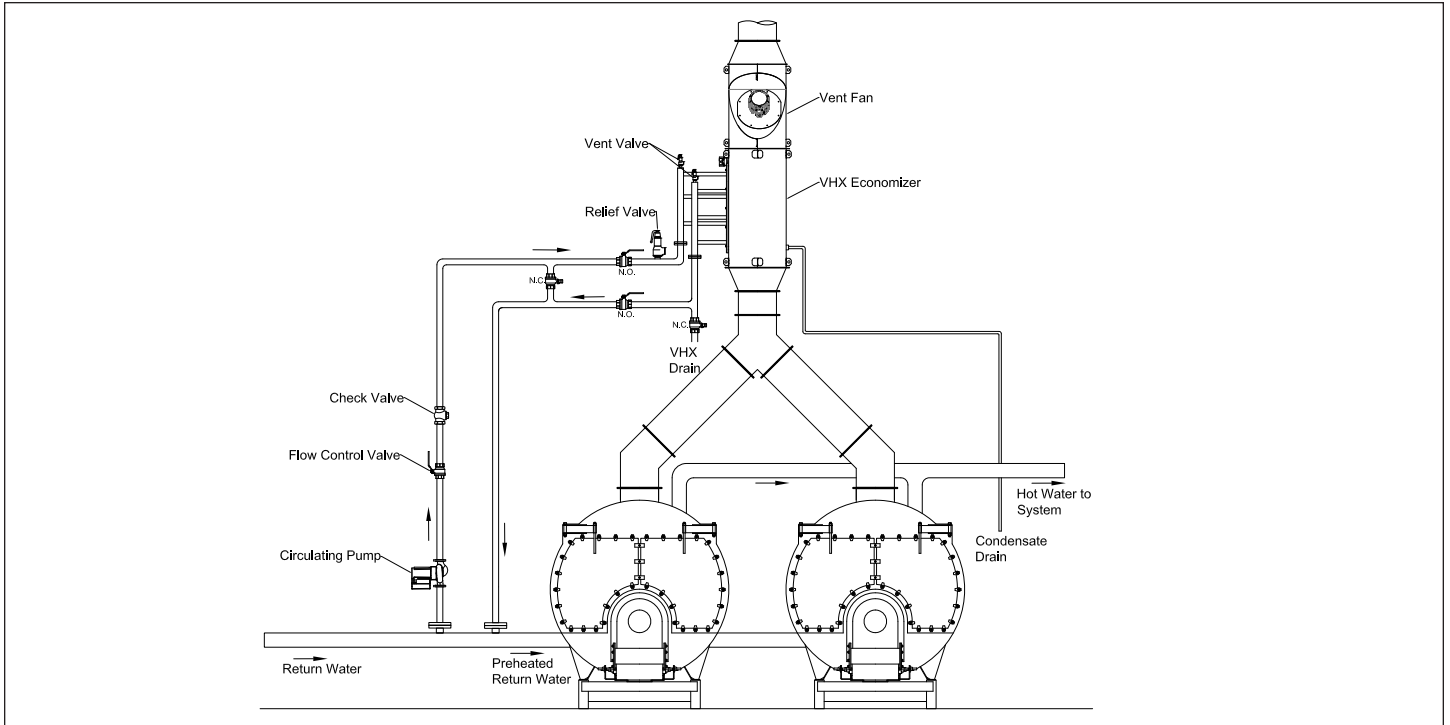

9.2 PREHEATING CIRCULATING FEED WATER

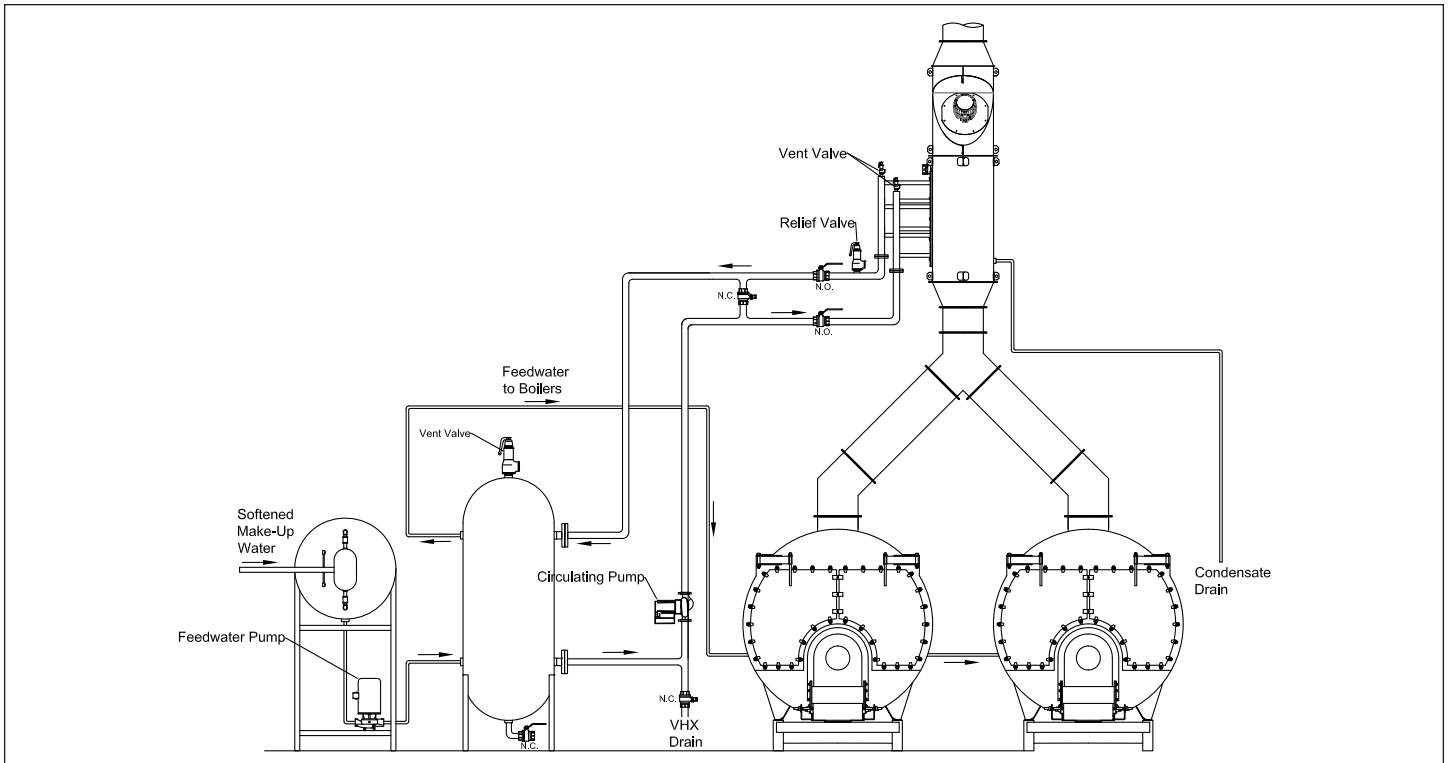

9.3 PREHEATING BOILER MAKE UP WATER

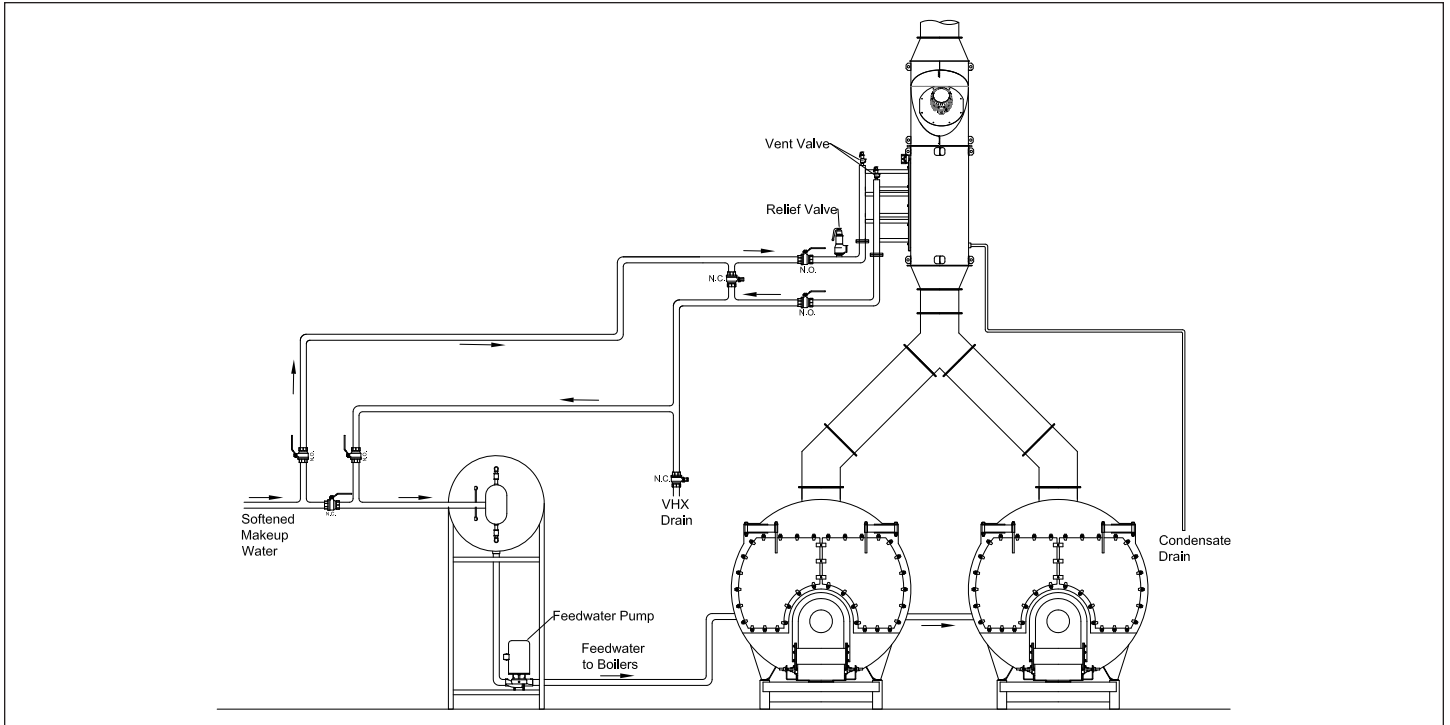

9.4 PREHEATING STEAM BOILER FEEDWATER WITH MODULATING FEED WATER VALVE

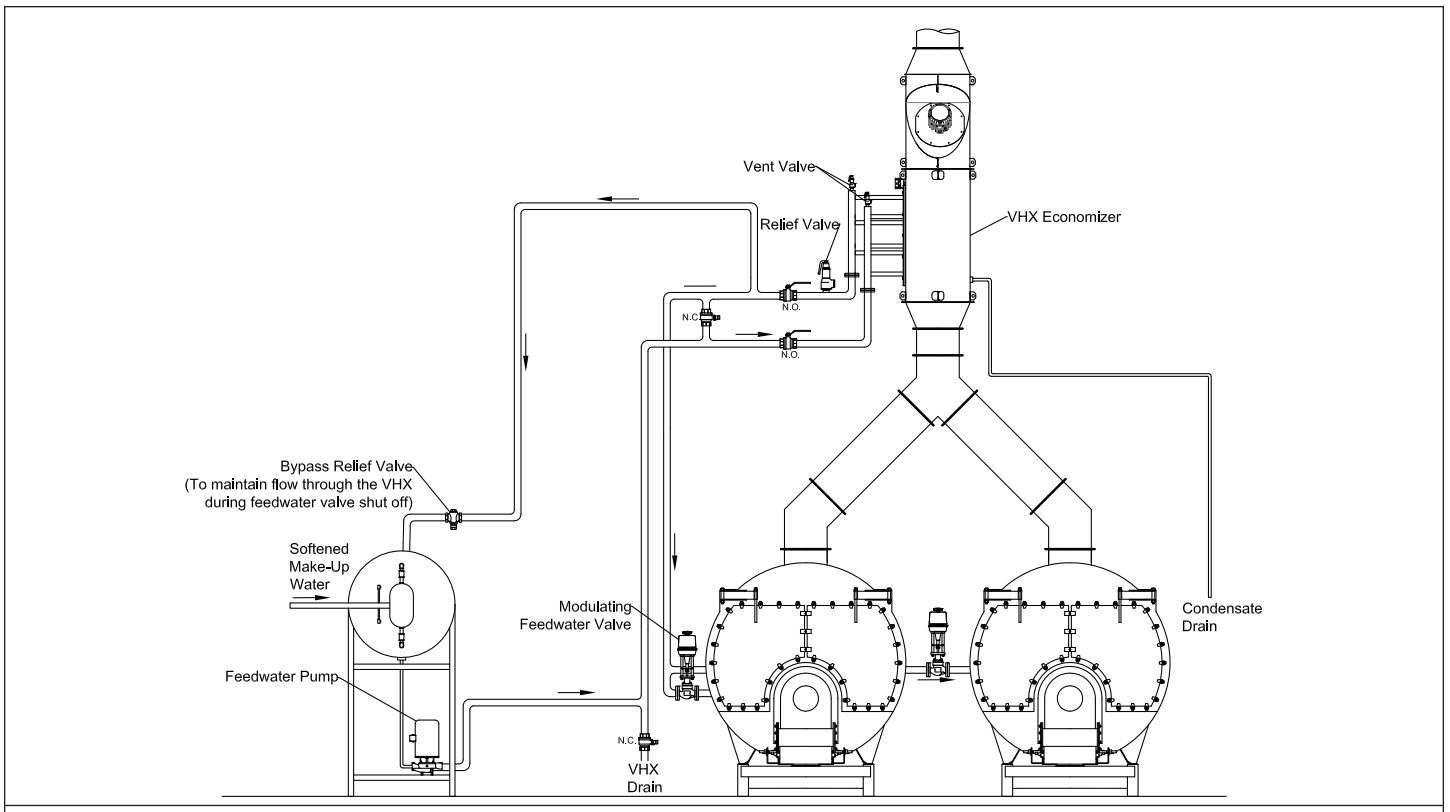

9.5 CIRCULATING MAKE UP WATER HEATING

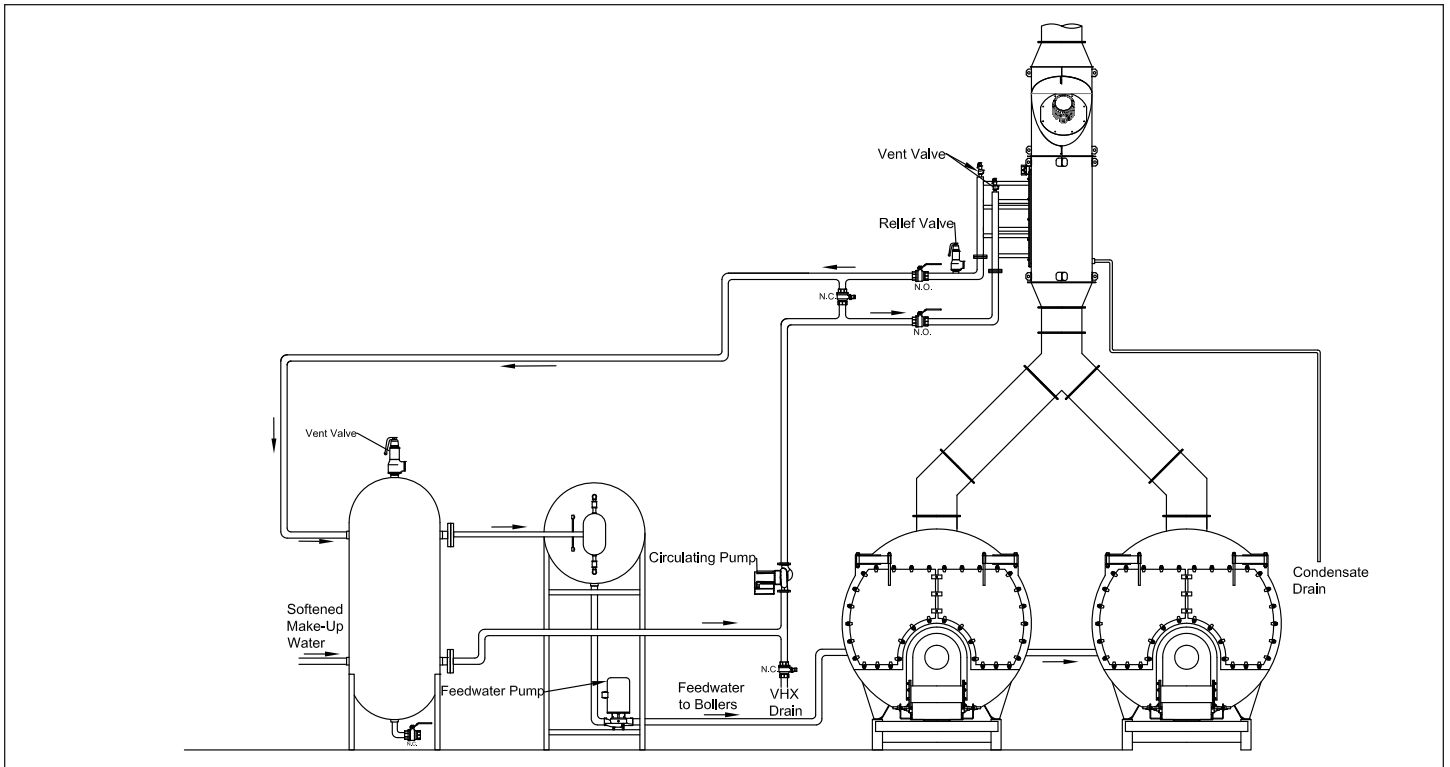

9.6 CONDENSATE RETURN HEATING

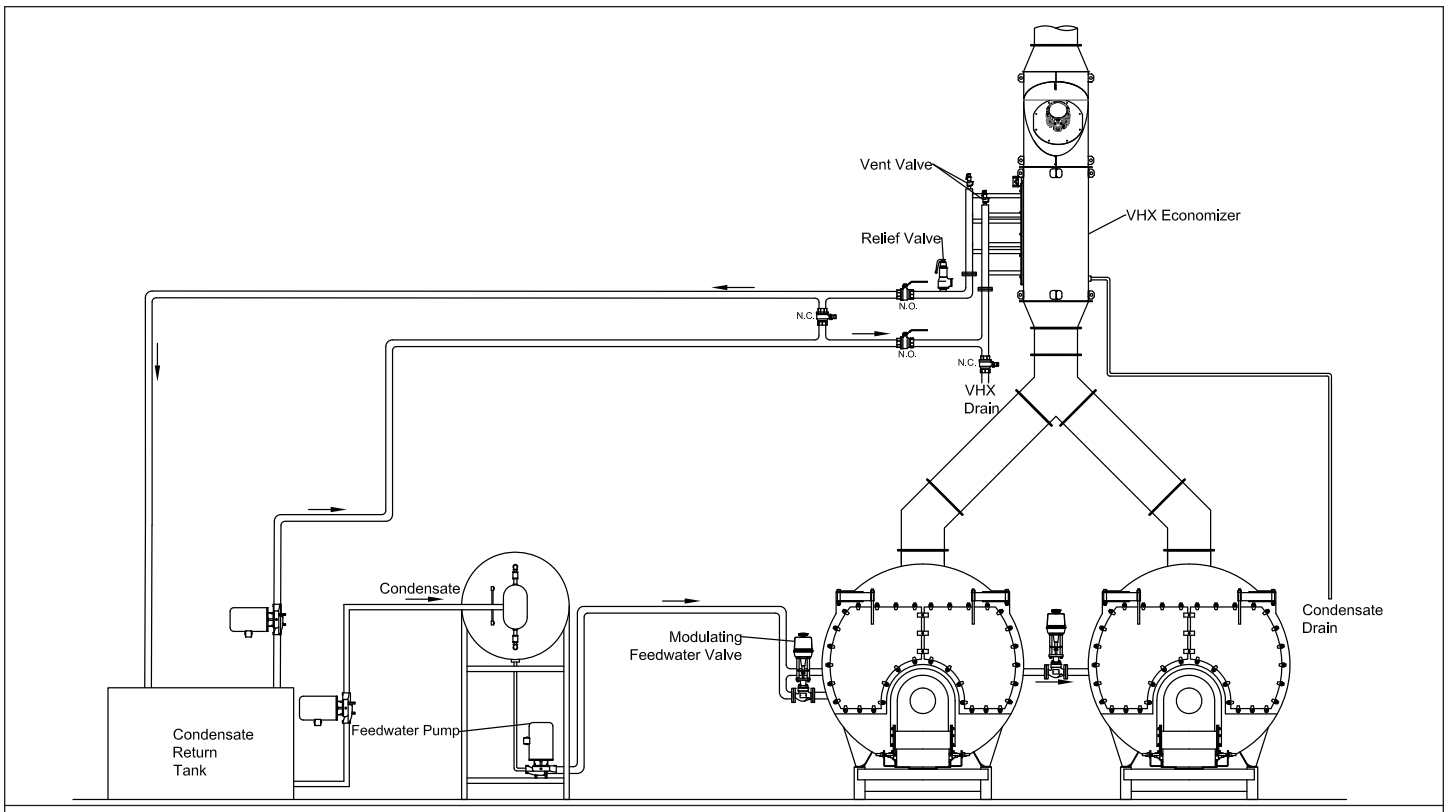

9.7 CALORIFIER HEATING LOOP

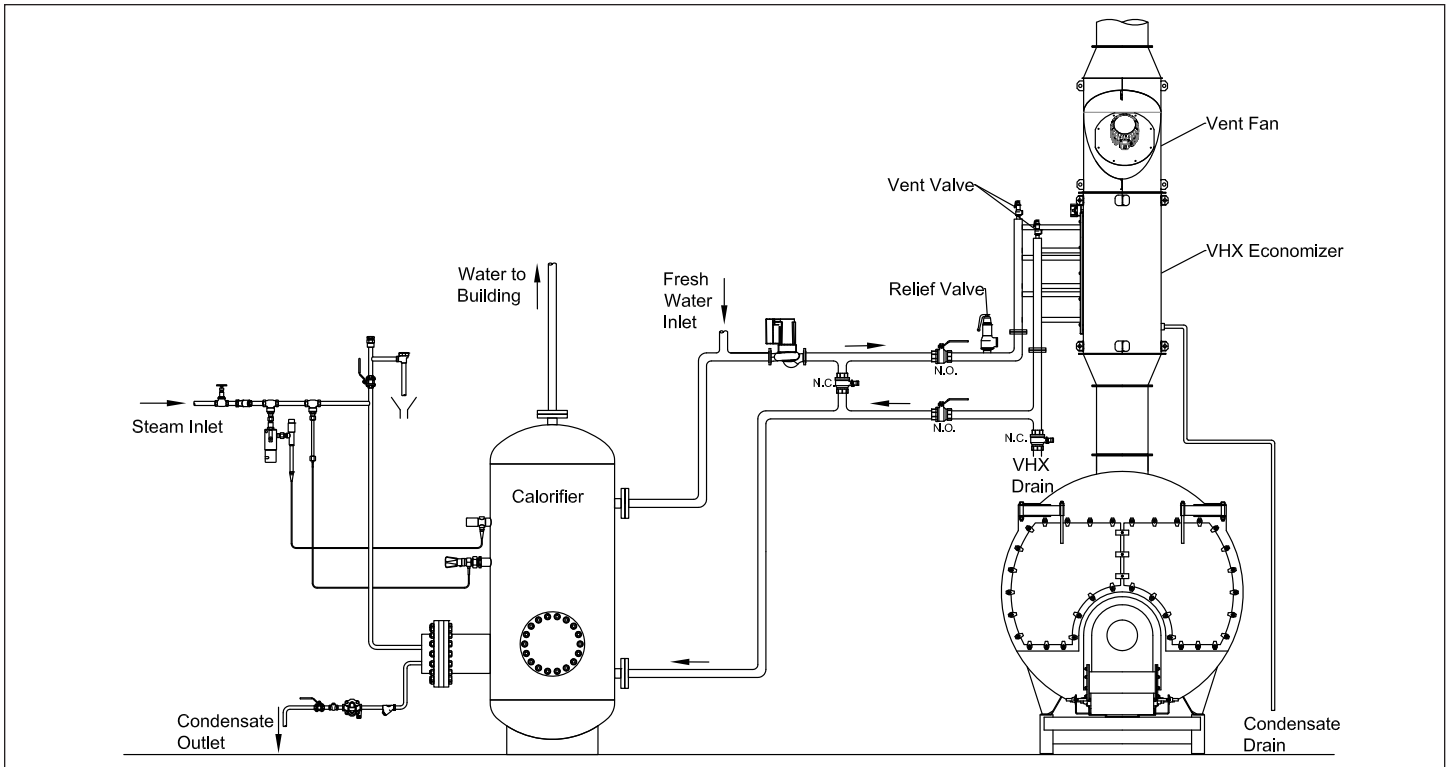

9.8 PROCESS WATER HEATING

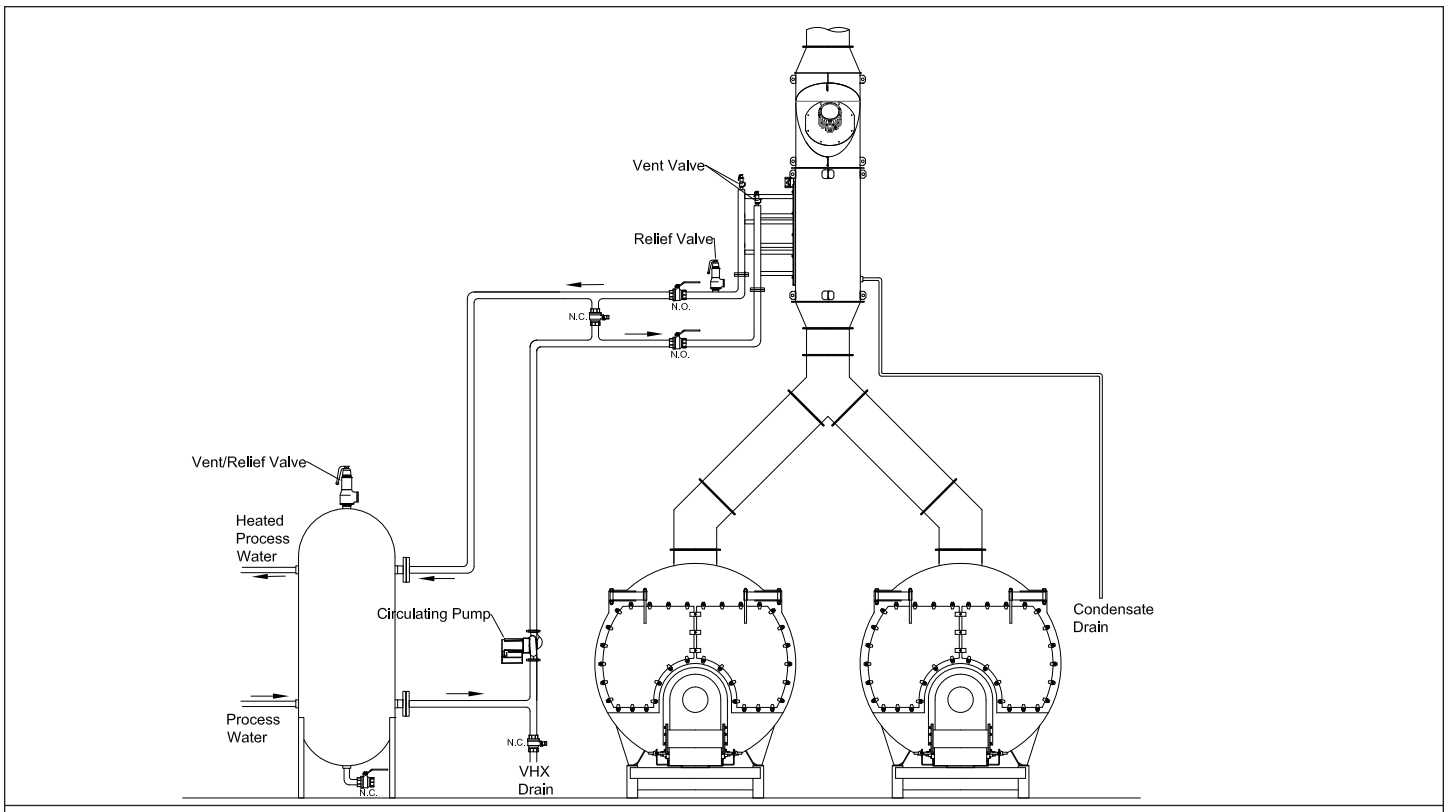

10. ECONOMIZER CONTROLS (HRC 80)

10.1 GENERAL

The HRC80 is a totally integrated heat recovery control system designed to work with the ENERVEX VHX-SR Heat Recovery systems.

It monitors inlet and outlet water and flue temperatures and limits the maximum water outlet temp to a desired level while maximizing heat recovery and efficiency. This controller can be used in conjunction with most ENERVEX draft controls.

The integrated bypass damper control features full modulating capabilities providing tighter control and added safety. Inlet and outlet flue temperatures are constantly monitored and the bypass damper will dynamically respond to water outlet temperature.

The HRC80 features a series of set points allowing maximum flexibility. The bypass set point maintains a maximum allowable water temperature. The bypass modulates open or closed as the water temperature fluctuates around the set point. The HRC80 can interlock pump and is capable of controlling a modulating water valve to maintain desired water temperature. A dry contact input communicates when there is a need for boiler feed water or to maintain a hot water tank or deaerator.

The Controller features a panel mounted, 132x64 pixel LCD graphic display used to interface, monitor and control all aspects of the application.



ENERVEX Inc.
1685 Bluegrass Lakes
Parkway
Alpharetta, GA 30004
USA

P: 770.587.3238
F: 770.587.4731
T: 800.255.2923
info@enervex.com
www.enervex.com

ENERVEX® 
VENTING DESIGN SOLUTIONS