

ENERVEX EDRIVE E3 MOTOR CONTROLLER

010.3210.0619 06.21

Installation & Operating Manual



NEMA 4X (IP 66)

0.37kW - 22kW / 0.5HP - 30HP

110 - 480V Single and Three-Phase Input

READ AND SAVE THESE INSTRUCTIONS!



LISTED

UL File E226333

ENERVEX Inc.
1685 Bluegrass Lakes
Parkway
Alpharetta, GA 30004
USA

P: 770.587.3238
F: 770.587.4731
T: 800.255.2923
info@enervex.com
www.enervex.com

ENERVEX® 
VENTING DESIGN SOLUTIONS

1. GENERAL INFORMATION AND RATINGS	
1.1 Identifying the Drive by Model Number	5
1.2 Product Rating Label Location	5
1.3 Understanding the Rating Label	5
2. SPECIFICATIONS AND DIMENSIONS	
2.1 Environmental	6
2.2 Rating Tables	6
2.3 Single Phase Operation of Three Phase Drives..	7
2.4 Additional Information for UL Compliance	7
2.5 Electrical Installation Requirements	7
2.6 Bolts and Torques	7
2.7 EMC Filter Disconnect	8
2.8 Dimensions	9
3. MECHANICAL INSTALLATION	
3.1 General	9
3.2 Guidelines for Mounting	9
3.3 Fittings	9
3.4 Removing Terminal Cover	10
3.5 Routine Maintenance	10
4. ELECTRICAL INSTALLATION	
4.1 General	11
4.2 Grounding Guidelines	11
4.3 Incoming Power Connection	12
4.4 Drive and Motor Connection	12
4.5 Motor Terminal Box Connections	13
4.6 Control Terminal Wiring	13
4.7 Connection Diagram	14
4.8 Control Terminal Connections	15
4.9 Motor Thermal Overload Protection	16
4.10 EMC Compliant Installation	16
4.11 Optional Brake Resistor	17
5. OPERATION	
5.1 Managing the Keypad	18
5.2 Operating Display	18
5.3 Changing Parameters	19
5.4 Read Only Parameter Access	19
5.5 Resetting Parameter	19
5.6 Resetting a Fault	19
5.7 LED Display	19
5.8 LED Display Meaning	19
6. PARAMETERS	
6.1 Standard Parameters	20
6.2 Parameter List	20
6.3 Parameter Functions	22
6.4 P-00 Read Only Status Parameters	37
7. MODBUS RTU COMMUNICATIONS	
7.1 Introduction	39
7.2 RJ45 Connector Configuration	39
7.3 Modbus Telegram Structure	39
7.3 Modbus Register Map	39
8. TROUBLESHOOTING	
8.1 Fault Code Messages	40

DECLARATION OF CONFORMITY

ENERVEX Inc. hereby states that the EDrive E3 product range conforms to the relevant safety provisions of the following council directives:

2014/30/EU (EMC) and 2014/35/EU (LVD)

Designed and manufacture is in accordance with the following harmonised European standards:

EN 61800-5-1: 2007 - Adjustable speed electrical power drive systems. Safety requirements. Electrical, thermal and energy.

EN 61800-3: 2004 / A1 2012 - Adjustable speed electrical power drive systems. EMC requirements and specific test methods

EN 55011: 2007 - Limits and Methods of measurement of radio disturbance characteristics of industrial, scientific and medical (ISM) radiofrequency equipment (EMC)

EN60529: 1992 - Specifications for degrees of protection provided by enclosures

ELECTROMAGNETIC COMPATIBILITY

All EDrives are designed with high standards of EMC in mind. All versions suitable for operation on Single Phase 230 volt and Three Phase 400 volt supplies and intended for use within the European Union and North America are fitted with an internal EMC filter. This EMC filter is designed to reduce the conducted emissions back into the mains supply via the power cables for compliance with the above harmonised European standards.

It is the responsibility of the installer to ensure that the equipment or system into which the product is incorporated complies with the EMC legislation of the country of use, and the relevant category. Within the European Union and North America, equipment into which this product is incorporated must comply with the EMC Directive 2004/108/EC. This User Guide provides guidance to ensure that the applicable standards may be achieved.

COPYRIGHT ENERVEX Inc. © 2019

All rights reserved. No part of this User Guide may be reproduced or transmitted in any form or by any means, electrical or mechanical including photocopying, recording or by any information storage or retrieval system without permission in writing from the publisher.

2 YEAR WARRANTY

All ENERVEX EDrives units carry a 2 year warranty against manufacturing defects from the date of manufacture. The manufacturer accepts no liability for any damage caused during or resulting from transport, receipt of delivery, installation or commissioning. The manufacturer also accepts no liability for damage or consequences resulting from inappropriate, negligent or incorrect installation, incorrect adjustment of the operating parameters of the drive, incorrect matching of the drive to the motor, incorrect installation, unacceptable dust, moisture, corrosive substances, excessive vibration or ambient temperatures outside of the design specification.

This user guide is the “original instructions” document. All non-English versions are translations of the “original instructions”.

The contents of this User Guide are believed to be correct at the time of printing. In the interest of a commitment to a policy of continuous improvement, the manufacturer reserves the right to change the specification of the product or its performance or the contents of the User Guide without notice.

This User Guide is for use with version 3.07 Firmware

ENERVEX Inc. adopts a policy of continuous improvement and whilst every effort has been made to provide accurate and up to date information, the information contained in this User Guide should be used for guidance purposes only and does not form the part of any contract.



This manual is intended as a guide for proper installation. ENERVEX Inc. cannot assume responsibility for the compliance or the non-compliance to any code, national, local or otherwise, for the proper installation of this drive or associated equipment. A hazard of personal injury and/or equipment damage exists if codes are ignored during installation.



This EDrive E3 contains high voltage capacitors that take time to discharge after removal of the main supply. Before working on the drive, ensure isolation of the main supply from line inputs. Wait ten (10) minutes for the capacitors to discharge to safe voltage levels. Failure to observe this precaution could result in severe bodily injury or loss of life.



Only qualified electrical personnel familiar with the construction and operation of this equipment and the hazards involved should install, adjust, operate, or service this equipment. Read and understand this manual and other applicable manuals in their entirety before proceeding. Failure to observe this precaution could result in severe bodily injury or loss of life.

IMPORTANT SAFETY INFORMATION

Please read the IMPORTANT SAFETY INFORMATION below, and all Warning and Caution information elsewhere.



DANGER: Indicates a potentially hazardous situation other than electrical, which if not avoided, could result in damage to property.



DANGER: Indicates a risk of electric shock, which, if not avoided, could result in damage to the equipment and possible injury or death.

This variable speed drive product (EDrive E3) is intended for professional incorporation into complete equipment or systems as part of a fixed installation. If installed incorrectly it may present a safety hazard. The EDrive E3 uses high voltages and currents, carries a high level of stored electrical energy, and is used to control mechanical devices that may cause injury. Close attention is required to system design and electrical installation to avoid hazards in either normal operation or in the event of equipment malfunction. Only qualified electricians are allowed to install and maintain this product.

System design, installation, commissioning and maintenance must be carried out only by personnel who have the necessary training and experience. They must carefully read this safety information and the instructions in this Guide and follow all information regarding transport, storage, installation and use of the EDrive E3, including the specified environmental limitations.

Do not perform any flash test or voltage withstand test on the EDrive E3. Any electrical measurements required should be carried out with the EDrive E3 disconnected.

Electric shock hazard! Disconnect and ISOLATE the EDrive E3 before attempting any work on it. High voltages are present at the terminals and within the drive for up to 10 minutes after disconnection of the electrical supply. Always ensure by using a suitable multimeter that no voltage is present on any drive power terminals prior to commencing any work.

Where supply to the drive is through a plug and socket connector, do not disconnect until 10 minutes have elapsed after turning off the supply.

Ensure correct grounding connections. The earth cable must be sufficient to carry the maximum supply fault current which normally will be limited by the fuses or MCB. Suitably rated fuses or MCB should be fitted in the mains supply to the drive, according to any local legislation or codes.

Ensure correct grounding connections and cable selection as per defined by local legislation or codes. The drive may have a leakage current of greater than 3.5mA; furthermore the earth cable must be sufficient to carry the maximum supply fault current which normally will be limited by the fuses or MCB. Suitably rated fuses or MCB should be fitted in the mains supply to the drive, according to any local legislation or codes.

Do not carry out any work on the drive control cables whilst power is applied to the drive or to the external control circuits.

Within the European Union, all machinery in which this product is used must comply with Directive 2006/42/EC, Safety of Machinery. In particular, the machine manufacturer is responsible for providing a main switch and ensuring the electrical equipment complies with EN60204-1.

The level of integrity offered by the EDrive E3 control input functions – for example stop/start, forward/reverse and maximum speed is not sufficient for use in safety-critical applications without independent channels of protection. All applications where malfunction could cause injury or loss of life must be subject to a risk assessment and further protection provided where needed.

The driven motor can start at power up if the enable input signal is present.

The STOP function does not remove potentially lethal high voltages. ISOLATE the drive and wait 10 minutes before starting any work on it. Never carry out any work on the Drive, Motor or Motor cable whilst the input power is still applied.

The EDrive can be programmed to operate the driven motor at speeds above or below the speed achieved when connecting the motor directly to the mains supply. Obtain confirmation from the manufacturers of the motor and the driven machine about suitability for operation over the intended speed range prior to machine start up.

Do not activate the automatic fault reset function on any systems whereby this may cause a potentially dangerous situation.

When mounting the drive, ensure that sufficient cooling is provided. Do not carry out drilling operations with the drive in place, dust and swarf from drilling may lead to damage.

The entry of conductive or flammable foreign bodies should be prevented. Flammable material should not be placed close to the drive

Never connect the mains power supply to the Output terminals U, V, W.

Do not install any type of automatic switch gear between the drive and the motor

Wherever control cabling is close to power cabling, maintain a minimum separation of 4 inches (100 mm) and arrange crossings at 90°.

Ensure that all terminals are tightened to the appropriate torque setting

Do not attempt to carry out any repair of the EDrive E3. In the case of suspected fault or malfunction, contact your local ENERVEX Representative for further assistance.

1. GENERAL INFORMATION AND RATINGS

This chapter contains information about the EDrive E3 including how to identify the drive.

1.1 IDENTIFYING THE DRIVE BY MODEL NUMBER

Each drive can be identified by its model number, as shown in Fig 1. The model number is on the shipping label and the drive nameplate. The model number includes the drive and any options.

1.2. PRODUCT RATING LABEL LOCATION

All EDrive E3 models carry a rating label, which can be located according to Fig 2:

1.3. UNDERSTANDING THE RATING LABEL

The product rating label provides the following information.

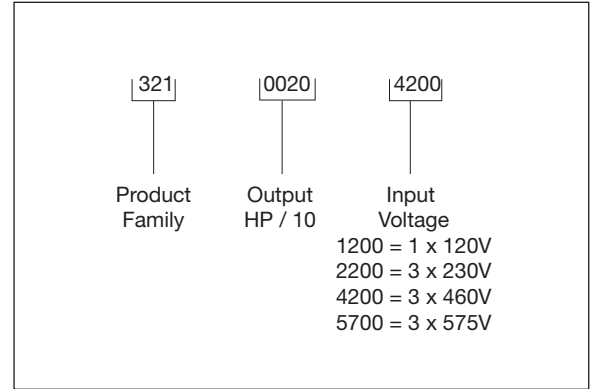

Fig 1

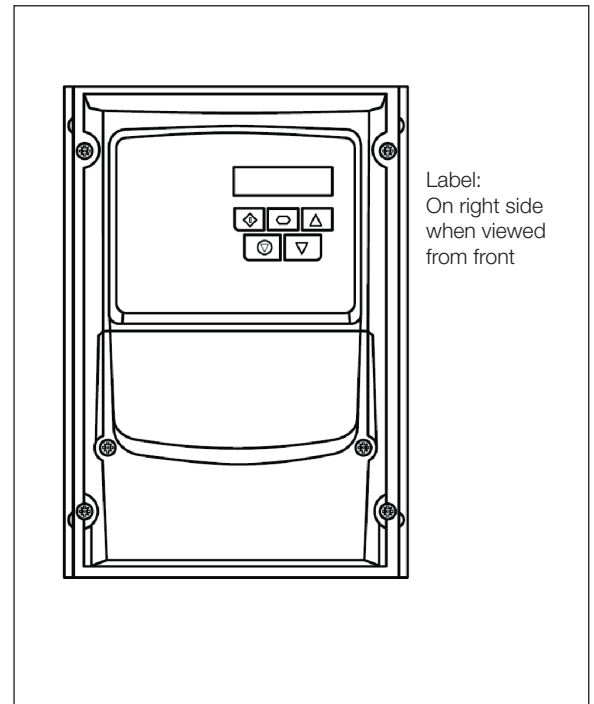

Fig 2

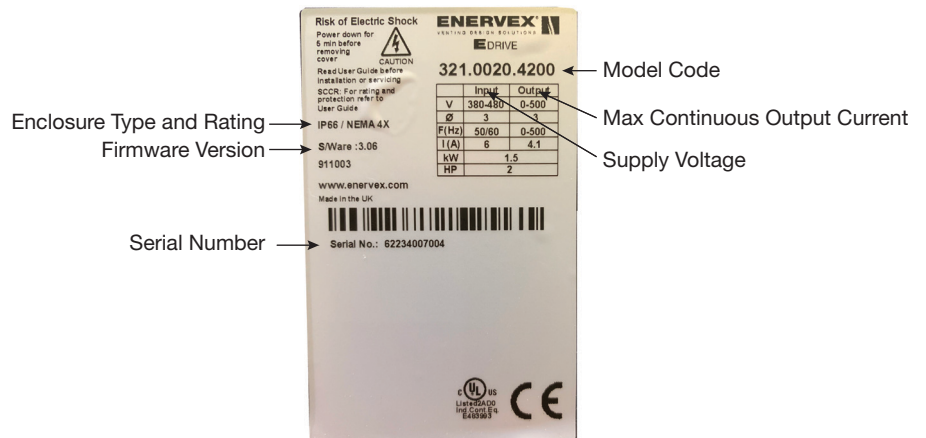

Fig 3

2. SPECIFICATIONS AND DIMENSIONS

2.1 ENVIRONMENTAL

Operational ambient temperature range	Open Drives	14 ...122°F / -10 ... 50°C (frost and condensation free)
	Enclosed Drives	-4 ...104°F / -20 ... 40°C (frost and condensation free)
Storage ambient temperature range		-40 ... 140°F / -40 ... 60°C
Maximum altitude		6,500 ft / 2000m. Derate above 3,200 ft / 1000m : 1% / 300 ft / 100m
Maximum humidity		95%, non-condensing

2.2 RATING TABLES

Model Number	Frame Size	kW	HP	Input Current	Fuse / MCB (Type B)		Maximum Cable Size		Output A	Recommended Brake Resistance Ω
					Non UL	UL	mm	AWG		
110 - 115 (+ / - 10%) V~ 1 Phase Input, 230V 3 Phase Output (Voltage Doubler)										
321.0005.1200	1	0.37	0.5	7.8	10	10	8	8	2.3	-
321.0010.1200	1	0.75	1	15.8	25	20	8	8	4.3	-
321.0015.1200	2	1.1	1.5	21.9	32	30	8	8	5.8	100
200 - 240 (+ / - 10%) V~ 1 Phase Input, 3 Phase Output										
321.0005.2300	1	0.37	0.5	3.7	10	6	8	8	2.3	-
321.0010.2300	1	0.75	1	7.5	10	10	8	8	4.3	-
321.0020.2300	1	1.5	2	12.9	16	17.5	8	8	7	-
200 - 240 (+ / - 10%) V~ 3 Phase Input, 3 Phase Output										
321.0005.2200	1	0.37	0.5	3.4	6	6	8	8	2.3	-
321.0010.2200	1	0.75	1	5.6	10	10	8	8	4.3	-
321.0020.2200	2	1.5	2	8.9	16	15	8	8	7	100
321.0030.2200	2	2.2	3	12.1	16	17.5	8	8	10.5	50
321.0050.2200	3	4	5	20.9	32	30	8	8	18	25
321.0075.2200	3	5.5	7.5	26.4	40	35	8	8	24	20
321.0100.022	4	7.5	10	33.3	40	45	16	5	30	15
321.0150.2200	4	11	15	50.1	63	70	16	5	46	10
380 - 480 (+ / - 10%)V~ 3 Phase Input, 3 Phase Output										
321.0010.4200	1	0.75	1	3.5	6	6	8	8	2.2	-
321.0020.4200	1	1.5	2	5.6	10	10	8	8	4.1	-
321.0030.4200	2	2.2	3	7.5	16	10	8	8	5.8	200
321.0050.4200	2	4	5	11.5	16	15	8	8	9.5	120
321.0075.4200	3	5.5	7.5	17.2	25	25	8	8	14	100
321.0100.4200	3	7.5	10	21.2	32	30	8	8	18	80
321.0150.4200	3	11	15	27.5	40	35	8	8	24	50
321.0200.4200	4	15	20	34.2	40	45	16	5	30	30
321.0250.4200	4	18.5	25	44.1	50	60	16	5	39	22
321.0300.4200	4	22	30	51.9	63	70	16	5	46	22

NOTE Cable sizes shown are the maximum possible that may be connected to the drive. Cables should be selected according to local wiring codes or regulations at the point of installation

2.3. SINGLE PHASE OPERATION OF THREE PHASE DRIVES

All drive models intended for operation from three phase mains power supply (e.g. model codes xxx.xxxx.2200/4200) may be operated from a single phase supply at up to 50% of maximum rated output current capacity.

In this case, the AC power supply should be connected to L1 (L) and L2 (N) power connection terminals only.

2.4 ADDITIONAL INFORMATION FOR UL COMPLIANCE

All EDrive E3 units are designed to meet the UL requirements. For an up to date list of UL compliant products, please refer to UL listing NMMS.E226333. In order to ensure full compliance, the table to the right and the following must be fully observed.

EDrive E3 provides motor overload protection in accordance with the National Electrical Code (US).

Where a motor thermistor is not fitted, or not utilised, Thermal Overload Memory Retention must be enabled by setting P-60 = 1.

Where a motor thermistor is fitted and connected to the drive, connection must be carried out according to the information shown in section 4.9.2. Motor Thermistor Connection on page 16.

2.5 ELECTRICAL INSTALLATION REQUIREMENTS

Incoming power supply connection must be according to section 4.4 Incoming Power Connection on page 12. Suitable Power and motor cables should be selected according to the data shown in section 2.2 Rating Tables on page 6 and the National Electrical Code or other applicable local codes. Motor Cable 75°C Copper must be used.

Power cable connections and tightening torques are shown in sections 2.6 Bolts on this page and Torques and 2.8 Dimensions on this page. Integral Solid State short circuit protection does not provide branch circuit protection. Branch circuit protection must be provided in accordance with the national electrical code and any additional local codes. Ratings are shown in section 2.2 Rating Tables on page 6.

Transient surge suppression must be installed on the line side of this equipment and shall be rated 480 Volt (phase to ground), 480 Volt (phase to phase), suitable for over voltage category iii and shall provide protection for a rated impulse withstand voltage peak of 4kV.

UL Listed ring terminals / lugs must be used for all bus bar and grounding connections.

2.6 BOLTS AND TORQUES

Recommended bolt sizes and torque values are shown in table to the right.

Input Power Supply Requirements				
Supply Voltage	200 – 240 RMS Volts for 230 Volt rated units, + / - 10% variation allowed. 240 Volt RMS Maximum			
	380 – 480 Volts for 400 Volt rated units, + / - 10% variation allowed, Maximum 500 Volts RMS			
Imbalance	Maximum 3% voltage variation between phase – phase voltages allowed			
	All EDrive E3 units have phase imbalance monitoring. A phase imbalance of > 3% will result in the drive tripping. For input supplies which have supply imbalance greater than 3% (typically the Indian sub- continent & parts of Asia Pacific including China) ENERVEX Drives recommends the installation of input line reactors.			
Frequency	50 – 60Hz + / - 5% Variation			
Short Circuit Capacity	Voltage Rating	Min kW (HP)	Max kW (HP)	Max Supply Short-circuit Current
	115V	0.37 (0.5)	1.1 (1.5)	100kA rms (AC)
	230V	0.37 (0.5)	11 (15)	100kA rms (AC)
	400 / 460V	0.75 (1)	22 (30)	100kA rms (AC)
All the drives in the above table are suitable for use on a circuit capable of delivering not more than the above specified maximum short-circuit Amperes symmetrical with the specified maximum supply voltage when protected by Class J fuses.				

	Frame Size 1, 2, 3	Frame Size 4
Mounting Bolts	4 x M5 (#8)	
Tightening Torque Control Terminals	4.5 lb-in (0.5 Nm)	
Tightening Torque Power Terminals	13 lb-in (1.5 Nm)	36.5 lb-in (4.1 Nm)

2.7 EMC FILER DISCONNECT

Drives with an EMC filter have an inherently higher leakage current to Ground (Earth). For applications where tripping occurs the EMC filter can be disconnected (on IP20 units only) by completely removing the EMC screw on the side of the product.

Remove the screw as indicated right.

The EDrive product range has input supply voltage surge suppression components fitted to protect the drive from line voltage transients, typically originating from lightning strikes or switching of high power equipment on the same supply.

When carrying out a HiPot (Flash) test on an installation in which the drive is built, the voltage surge suppression components may cause the test to fail. To accommodate this type of system HiPot test, the voltage surge suppression components can be disconnected by removing the VAR screw. After completing the HiPot test, the screw should be replaced and the HiPot test repeated. The test should then fail, indicating that the voltage surge suppression components are once again in circuit.

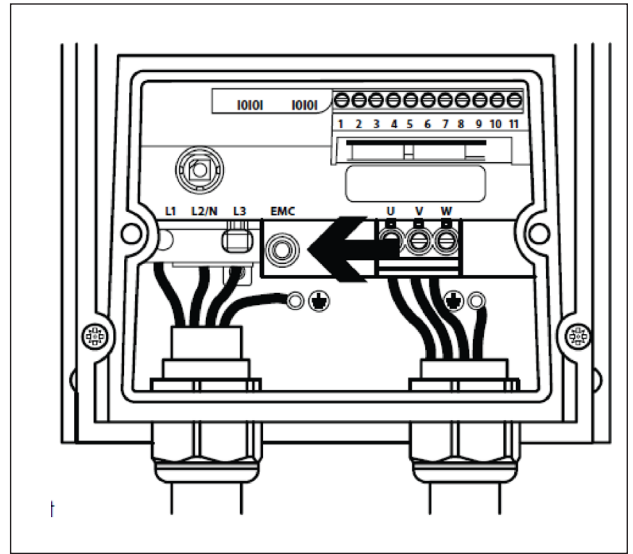
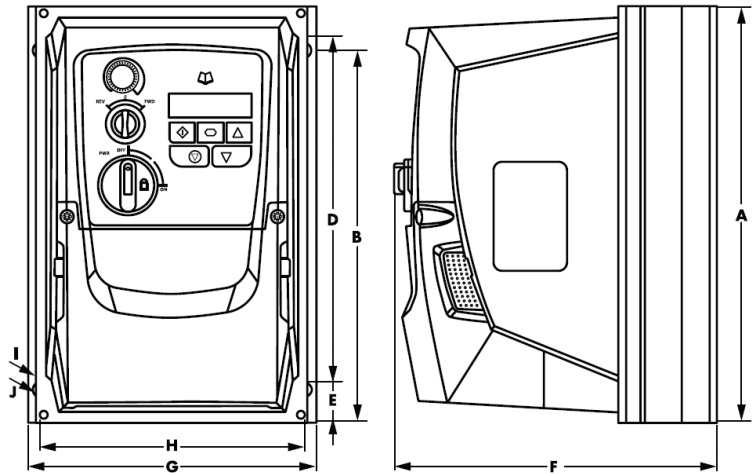

Fig 4

2.8 DIMENSIONS



Frame Size	A	B	D	E	F	G	H	I	J	Weight Kg (lbs)
1	9.13 (232)	8.15 (2070)	7.44 (189)	0.98 (25)	7.05 (179)	6.34 (161)	5.85 (148)	0.16 (4)	0.31 (8)	6.8 (3.1)
2	10.12 (257)	8.67 (220)	7.87 (200)	1.12 (29)	7.36 (187)	7.40 (188)	6.93 (176)	0.17 (4)	0.33 (9)	9.0 (4.1)
3	12.20 (310)	10.89 (277)	9.00 (252)	1.31 (33)	9.92 (252)	8.3 (211)	7.78 (198)	0.17 (4)	0.33 (9)	16.7 (7.6)
4	16.5 (420)	15.8 (400)	11.08 (300)	15.8 (400)	8.4 (212)	6.7 (171)	8.89 (226)	0.14 (4)	0.33 (9)	20.1 (9.1)

3. MECHANICAL INSTALLATION

3.1 GENERAL

The EDrive E3 should be mounted in a vertical position only, on a flat, flame resistant, vibration free mounting using the integral mounting holes or DIN Rail clip (Frame Sizes 1 and 2 only).

Do not mount flammable material close to the EDrive E3.

Ensure that the minimum cooling air gaps, as detailed in section 3.2 Guidelines for Mounting below and 3.3 Fittings below are left clear.

Ensure that the ambient temperature range does not exceed the permissible limits for the EDrive E3 given in section 2.1. Environmental on page 6.

Provide suitable clean, moisture and contaminant free cooling air sufficient to fulfil the cooling requirements of the EDrive E3.

3.2 GUIDELINES FOR MOUNTING

Before mounting the drive, ensure that the chosen location meets the environmental condition requirements for the drive shown in section 2.1. Environmental on page 6.

The drive must be mounted vertically, on a suitable flat surface.

The minimum mounting clearances as shown in the table below must be observed.

The mounting site and chosen mountings should be sufficient to support the weight of the drives.

Using the drive as a template, or the dimensions shown above, mark the locations required for drilling.

3.3 FITTINGS

The use of suitable conduit fittings is required to maintain the appropriate IP / Nema rating. The bottom plate, see fig 6, has pre-moulded cable entry holes for power and motor connections suitable for use with fittings as shown in the following table. Where additional holes are required, these can be drilled to suitable size. Please take care when drilling to avoid leaving any particles within the product.

UL rated ingress protection ("Type") is only met when cables are installed using a UL recognized conduit fitting for a flexible conduit system which meets the required level of protection ("Type").

For conduit installations the conduit entry holes require standard opening to the required sizes specified per the NEC.

Not intended for installation using rigid conduit system.

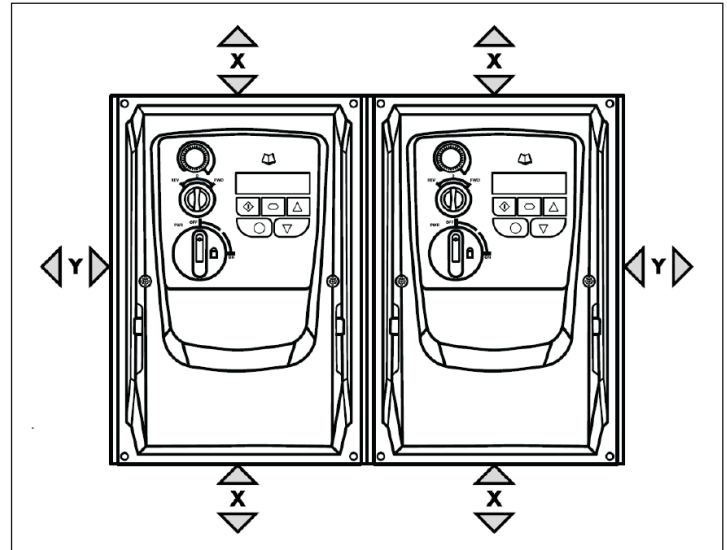

Fig 5

Drive Size	X Above & Below		Y Either Side		Conduit Hole Sizes		
	in	mm	in	mm	Power	Motor	Control
1	7.87	200	0.39	10	PG13.5	PG13.5	PG13.5
2	7.87	200	0.39	10	PG21	PG21	PG13.5
3	7.87	200	0.39	10	PG21	PG21	PG13.5
4	7.87	200	0.39	10	PG29	PG29	PG13.5

NOTE:

Typical drive heat losses are 3% of operating load conditions.

Above are guidelines only and the operating ambient temperature of the drive MUST be maintained at all times.

Drive Size	Power & Motor Cables			
	Hole Size		Fitting	
1	22mm	7/8 in	M20	PG13.5
2 & 3	29mm	1-1/8 in	M25	PG31
4	40mm	1-5/8 in	M40	PG29

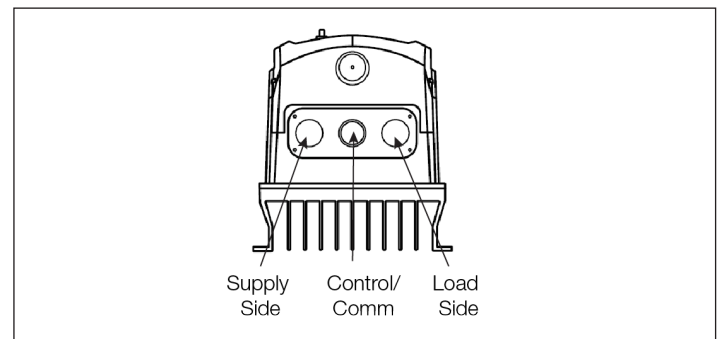

Fig 6

3.4 REMOVING THE TERMINAL COVER

To access the connection terminals, the drive front cover needs to be removed.

Removing the 2 screws on the front of the product allows access to the connection terminals, as shown to the right

3.5 ROUTINE MAINTENANCE

The drive should be included within the scheduled maintenance program so that the installation maintains a suitable operating environment, this should include:

- Ambient temperature is at or below that set out in section 2.1. Environmental on page 6.
- Heat sink fans freely rotating and dust free.
- The Enclosure in which the drive is installed should be free from dust and condensation; furthermore ventilation fans and air filters should be checked for correct air flow.

Checks should also be made on all electrical connections, ensuring screw terminals are correctly torqued; and that power cables have no signs of heat damage.

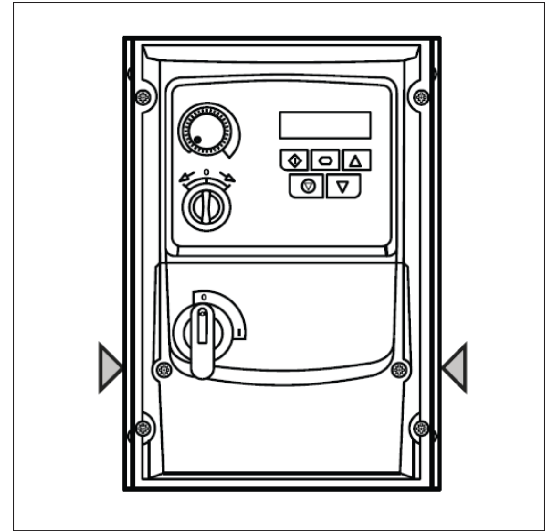

Fig 6

4. ELECTRICAL INSTALLATION

4.1 GENERAL

All wiring must be in compliance with the local codes or in their absence, with the National Electric Code, NFPA70. All wiring should meet these requirements: installed in rigid metal conduit, intermediate metal conduit, rigid non-metallic conduit, electrical metallic tubing, or be otherwise suitably protected from physical damage.

Note: If any of the original wire supplied with the system must be replaced, use similar wire of the same temperature rating. Otherwise, insulation may melt or degrade, exposing bare wire.

4.2 GROUNDING GUIDELINES

The ground terminal of each EDrive E3 should be individually connected DIRECTLY to the source breaker panel ground bus bar (through the filter if installed). EDrive E3 ground connections should not loop from one drive to another, or to, or from any other equipment. Ground loop impedance must confirm to local industrial safety regulations. To meet UL regulations, UL approved ring crimp terminals should be used for all ground wiring connections.

The drive Safety Ground must be connected to system ground. Ground impedance must conform to the requirements of national and local industrial safety regulations and/or electrical codes. The integrity of all ground connections should be checked periodically.

Protective Earth Conductor

The Cross sectional area of the ground conductor must be at least equal to that of the incoming supply conductor.

Safety Ground

This is the safety ground for the drive that is required by code. One of these points must be connected to adjacent building steel (girder, joist), a floor ground rod, or bus bar. Grounding points must comply with local codes.

Motor Ground

The motor ground must be connected to one of the ground terminals on the drive.

Ground Fault Monitoring

As with all inverters, a leakage current to earth can exist. The EDrive E3 is designed to produce the minimum possible leakage current whilst complying with worldwide standards. The level of current is affected by motor cable length and type, the effective switching frequency, the earth connections used and the type of RFI filter installed. If an ELCB (Earth Leakage Circuit Breaker) is to be used, the following conditions apply:

- A Type B Device must be used.
- The device must be suitable for protecting equipment with a DC component in the leakage current.
- Individual ELCBs should be used for each EDrive E3.

Shield Termination (Cable Screen)

The safety ground terminal provides a grounding point for the motor cable shield. The motor cable shield connected to this terminal

(drive end) should also be connected to the motor frame (motor end). Use a shield terminating or EMI clamp to connect the shield to the safety ground terminal.



DANGER

This manual is intended as a guide for proper installation. ENERVEX cannot assume responsibility for the compliance or the non-compliance to any code, national, local or otherwise, for the proper installation of this drive or associated equipment. A hazard of personal injury and/or equipment damage exists if codes are ignored during installation.



DANGER

This EDrive E3 contains high voltage capacitors that take time to discharge after removal of the main supply. Before working on the drive, ensure isolation of the main supply from line inputs. Wait ten (10) minutes for the capacitors to discharge to safe voltage levels. Failure to observe this precaution could result in severe bodily injury or loss of life.



DANGER

Only qualified electrical personnel familiar with the construction and operation of this equipment and the hazards involved should install, adjust, operate, or service this equipment. Read and understand this manual and other applicable manuals in their entirety before proceeding. Failure to observe this precaution could result in severe bodily injury or loss of life.

4.3 INCOMING POWER CONNECTION

4.3.1 Cable Selection

For single-phase supply, the mains power cables should be connected to Line/Neutral, L1/L2.

For three-phase supplies, the mains power cables should be connected to L1, L2, and L3. Phase sequence is not important.

For compliance with CE and C Tick EMC requirements, refer to section 4.10 EMC Compliant Installation on page 16.

A fixed installation is required according to IEC61800-5-1 with a suitable disconnecting device installed between the EDrive E3 and the AC Power Source. The disconnecting device must conform to the local safety code / regulations (e.g. within Europe, EN60204-1, Safety of machinery).

The National Electr Code (NEC) must be followed for cable sizing minimum requirements unless local codes increase NEC minimum requirements. Maximum dimensions are given in section 2.2. Rating Tables on page 6.

4.3.2 Fuse/Circuit Breaker Selection

Suitable fuses to provide wiring protection of the input power cable should be installed in the incoming supply line, according to the data in section 2.2. Rating Tables on page 6. The fuses must comply with any local codes or regulations in place. In general, type gG (IEC 60269) or UL type J fuses are suitable; however in some cases type aR fuses may be required. The operating time of the fuses must be below 0.5 seconds.

Where allowed by local regulations, suitably dimensioned type B MCB circuit breakers of equivalent rating may be utilised in place of fuses, providing that the clearing capacity is sufficient for the installation.

The maximum permissible short circuit current at the EDrive E3 Power terminals as defined in IEC60439-1 is 100kA.

4.3.3. Optional Input Choke

An optional Input Choke is recommended to be installed in the supply line for drives where any of the following conditions occur:

- The incoming supply impedance is low or the fault level / short circuit current is high.
- The supply is prone to dips or brown outs.
- An imbalance exists on the supply (3 phase drives).
- The power supply to the drive is via a busbar and brush gear system (typically overhead Cranes).

In all other installations, an input choke is recommended to ensure protection of the drive against power supply faults. Part numbers are shown in the table.

Supply	Frame Size	AC Input Inductor
230 Volt 1-Phase	1	OPT-2-L1016-20
	2	OPT-2-L1025-20
	3	N/A
400 Volt 3-Phase	2	OPT-2-L3006-20
	2	OPT-2-L30010-20
	3	OPT-2-L3036-20
	4	OPT-2-L3050-20

4.4 DRIVE AND MOTOR CONNECTION

The drive inherently produces fast switching of the output voltage (PWM) to the motor compared to the mains supply, for motors which have been wound for operation with a variable speed drive then there is no preventative measures required, however if the quality of insulation is unknown then the motor manufacturer should be consulted and preventative measures may be required.

The motor should be connected to the EDrive E3 U, V, and W terminals using a suitable 3 or 4 core cable. Where a 3 core cable is utilised, with the shield operating as an earth conductor, the shield must have a cross sectional area at least equal to the phase conductors when they are made from the same material. Where a 4 core cable is utilised, the earth conductor must be of at least equal cross sectional area and manufactured from the same material as the phase conductors.

The motor earth must be connected to one of the EDrive E3 earth terminals.

Maximum permitted motor cable length for all models: 100 meters shielded, 150 meters unshielded.

Where multiple motors are connected to a single drive using parallel cables, an output choke must be installed.

4.5 MOTOR TERMINAL BOX CONNECTIONS

Do not install any mechanical or electro-mechanical switching devices between the drive and motor. Where a local isolator is installed close to the motor, this should be interlocked with the drive control circuit to ensure the drive is disabled when the motor is isolated.

Most general purpose motors are wound for operation on dual voltage supplies. This is indicated on the nameplate of the motor. This correct voltage setting must be selected when installing the motor by selecting either STAR or DELTA connection. STAR always gives the higher of the two voltage ratings.

4.6 CONTROL TERMINAL WIRING

All analog signal cables should be suitably shielded. Twisted pair cables are recommended.

Power and Control Signal cables should be routed separately where possible, and must not be routed parallel to each other.

Signal levels of different voltages e.g. 24 Volt DC and 110 Volt AC, should not be routed in the same cable.

Maximum control terminal tightening torque is 0.5Nm.

Control Cable entry conductor size: 30 – 12 AWG.

(0.05 – 2.5mm²). Practical control cable size range = 24-16 AWG.

FRAME SIZE 1

Single Phase

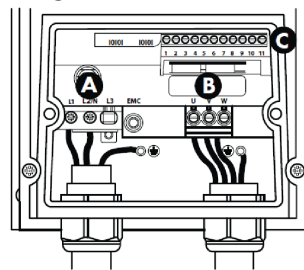

Three-Phase

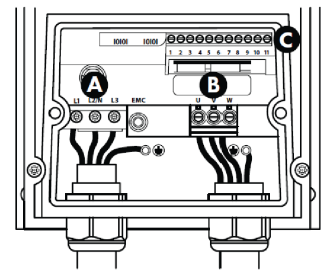

FRAME SIZES 2, 3 AND 4

Single Phase

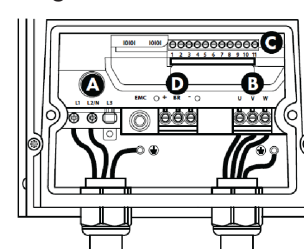

Three-Phase

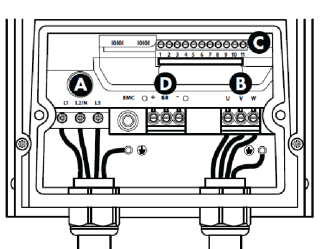

- A - Incoming Power Connections see section 4.3 Incoming Power Connection for more information
- B - Motor Connections see section 4.4 Drive and Motor Connection for more information
- C - Control Terminal Connections see section 4.8 Control Terminal Connections for more information
- D - N/A

Incoming Supply Voltage	Motor Nameplate Voltages	Connection	
230	230 / 400	Delta	
400	400 / 690		
400	230 / 400	Star	

4.7 CONNECTION DIAGRAM

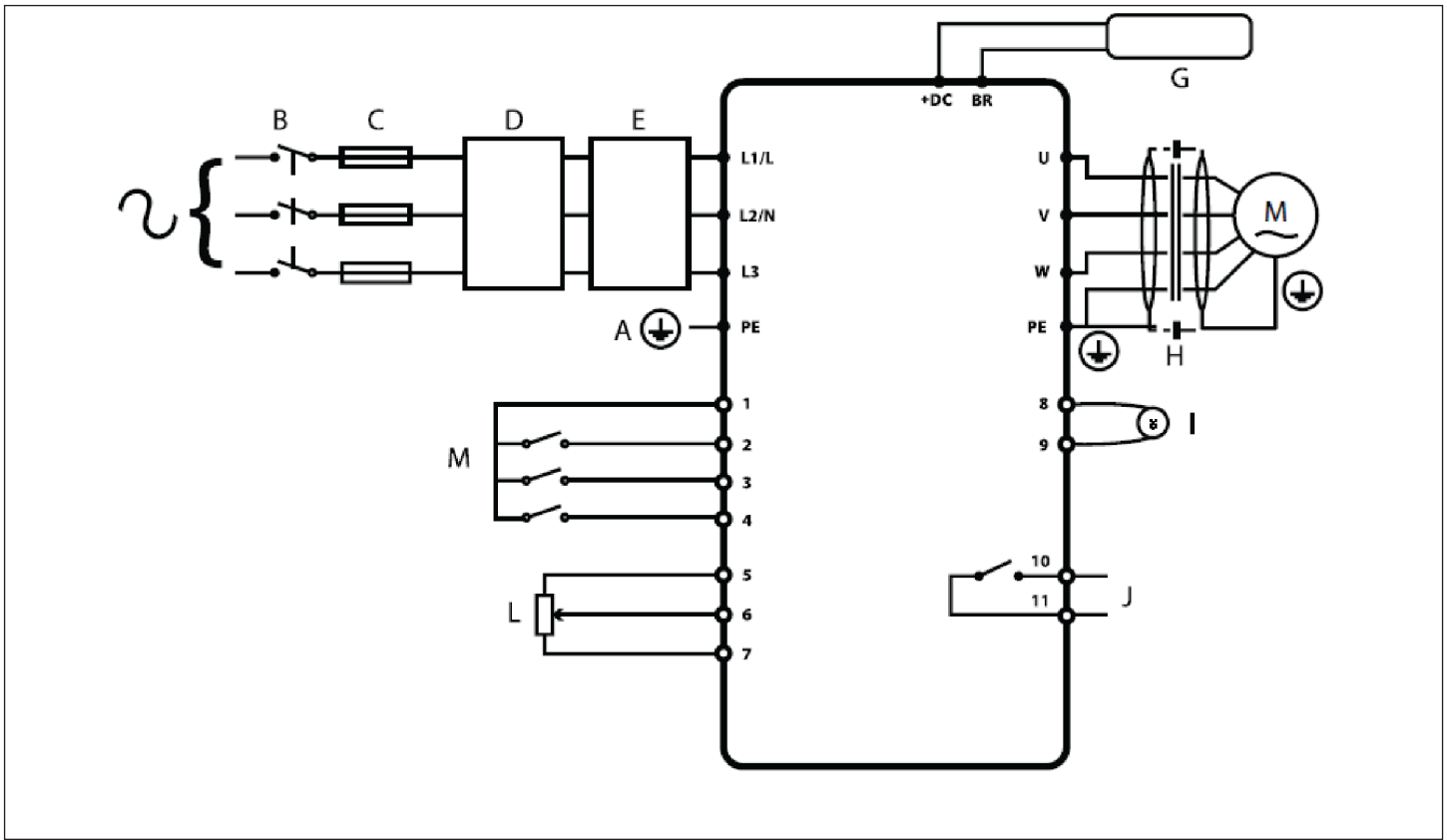

	Key	Sec.	Page
A	Grounding (PE) Connection	4.2	11
B	Incoming Power Connection	4.3	12
C	Fuse / Circuit Breaker Selection	4.3.2	12
D	Optional Input Choke	4.3.3	12
E	Optional External EMC Filter	4.10	16
F	Not Used		
G	Optional Brake Resistor	4.11	16
H	Motor Connection	4.4	13
I	Analog Output	4.8.1	15
J	Relay Output	4.8.2	15
K	Not Used		
L	Analog Inputs	4.8.3	15
M	Digital Inputs	4.8.4	16

4.8 CONTROL TERMINAL CONNECTIONS

Default Connections

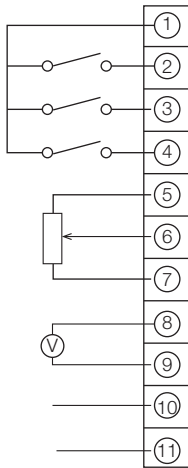

Control Terminal	Signal	Description	
1	+24Vdc User Output	+24Vdc user output, 100mA	
		DO NOT CONNECT AN EXTERNAL VOLTAGE SOURCE TO THIS TERMINALS	
2	Digital Input 1	Positive Logic: "Logic 1" input voltage range: 8V ... 30V DC "Logic 0" input voltage range: 0V ... 4V DC	
3	Digital Input 2		
4	Digital Input 3 / Analog Input 2	Digital: 8 to 30V Analog: 0 to 10V, 0 to 20mA or 4 to 20mA	
5	+10V User Output	+10V, 1mA, 1k minimum	
6	Analog Input 1 / Digital Input 4	Analog: 0 to 10V, 0 to 20mA or 4 to 20mA Digital: 8 to 30V	
7	0V	0 Volt Common, Internally connected to Terminal 9	
8	Analog Output / Digital Output	Analog: 0 to 10V Digital: 0 to 24V	20mA maximum
9	0V	0 Volt Common, Internally connected to Terminal 7	
10	Relay Common		
11	Relay NO Contact	Contact 250V AC, 6A / 30V DC, 5A	

4.8.1 Analog Output

The analog output function may be configured using parameter P-25, which is described in section 6.2.2 Extended Parameters on page 21.

The output has two operating modes, dependent on the parameter selection:

- Analog Mode
The output is a 0 – 10 volt DC signal, 20mA max load current.
- Digital Mode
The output is 24 volt DC, 20mA max load current.

4.8.2. Relay Output

The relay output function may be configured using parameter P-18, which is described in section 6.2.2 Extended Parameters on page 21.

4.8.3. Analog Inputs

Two analog inputs are available, which may also be used as Digital Inputs if required. The signal formats are selected by parameters as follows:

- Analog Input 1 Format Selection Parameter P-16
- Analog Input 2 Format Selection Parameter P-47.

These parameters are described more fully in section 6.2.2 Extended Parameters on page 21.

The function of the analog input, e.g. for speed reference or PID feedback for example is defined by parameters P-15. The function of these parameters and available options is described in section 6.

4.8.4. Digital Inputs

Up to four digital inputs are available. The function of the inputs is defined by parameters P-12 on page 24 and P-15, on page 28.

4.9 MOTOR THERMAL OVERLOAD PROTECTION

4.9.1. Internal Thermal Overload Protection

The drive has an in-built motor thermal overload function; this is in the form of an “I.t-trP” trip after delivering >100% of the value set in P-08 for a sustained period of time (e.g. 150% for 60 seconds).

4.9.2. Motor Thermistor Connection

Where a motor thermistor is to be used, it should be connected as shown to the right.

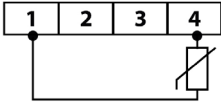
Control Terminal Strip	Additional Information
	<p>Compatible Thermistor: PTC Type, 2.5k trip Level</p> <ul style="list-style-type: none"> Use a setting of P-15 that has input 3 function as External Trip, e.g. P-15 = 3. Refer to Section 7 for further details. Analog and Digital Input Macro Configurations on page 31 for further details. Set P-47 = “Ptc-th”

4.10 EMC COMPLIANT INSTALLATION

1 A screened (shielded) cable suitable for fixed installation with the relevant mains voltage in use. Braided or twisted type screened cable where the screen covers at least 85% of the cable surface area, designed with low impedance to HF signals. Installation of a standard cable within a suitable steel or copper tube is also acceptable.

2 A cable suitable for fixed installation with relevant mains voltage with a concentric protection wire. Installation of a standard cable within a suitable steel or copper tube is also acceptable.

3 A cable suitable for fixed installation with relevant mains voltage. A shielded type cable is not necessary.

4 A shielded cable with low impedance shield. Twisted pair cable is recommended for analog signals.

5 The cable screen should be terminated at the motor end using an EMC type gland allowing connection to the motor body through the largest possible surface area. Where drives are mounted in a steel control panel enclosure, the cable screen may be terminated directly to the control panel using a suitable EMC clamp or gland, as close to the drive as possible. For IP66 drives, connect the motor cable screen to the internal ground clamp.

6 Compliance with category C1 conducted emissions only is achieved. For compliance with category C1 radiated emissions, additional measures may be required, contact your Sales Partner for further assistance.

7 Permissible cable length with additional external EMC filter.

Category	Supply Cable Type	Motor Cable Type	Control Cables	Max. Permissible Motor Cable Length
C1 ⁶	Shielded ¹	Shielded ^{1,5}	Shielded ⁴	1M / 5M ⁷ 3 ft / 15 ft ⁷
C2	Shielded ²	Shielded ^{1,5}		5M / 25M ⁷ 15 ft / 75 ft ⁷
C3	Shielded ³	Shielded ^{1,2}		25M / 100M ⁷ 75 ft / 300 ft ⁷

4.11 OPTIONAL BRAKE RESISTOR

EDrive E3 Frame Size 2 and above units have a built in Brake Transistor. This allows an external resistor to be connected to the drive to provide improved braking torque in applications that require this.

The brake resistor should be connected to the “+” and “BR” terminals as shown.

The voltage level at these terminals may exceed 800VDC.



Stored charge may be present after disconnecting the mains power.







Allow a minimum of 10 minutes discharge after power off before attempting any connection to these terminals.

Suitable resistors and guidance on selection can be obtained from your ENERVEX Sales Partner.





5. OPERATION

5.1 MANAGING THE KEYPAD

The drive is configured and its operation monitored via the keypad and display.

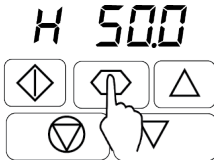
	NAVIGATE	Used to display real-time information, to access and exit parameter edit mode and to store parameter changes	
	UP	Used to increase speed in real-time mode or to increase parameter values in parameter edit mode	
	DOWN	Used to decrease speed in real-time mode or to decrease parameter values in parameter edit mode	
	RESET / STOP	Used to reset a tripped drive. When in Keypad mode is used to Stop a running drive.	
	START	When in keypad mode, used to Start a stopped drive or to reverse the direction of rotation if bidirectional keypad mode is enabled	

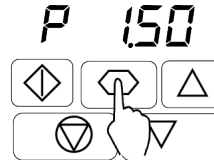

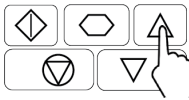
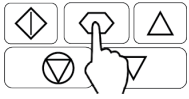
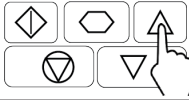
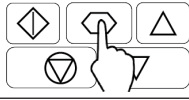
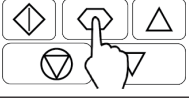

5.2 OPERATING DISPLAY

				
Drive Stopped / Disabled	Drive is enabled / running, display shows the output frequency (Hz)	Press the Navigate key for < 1 second. The display will show the motor current (Amps)	Press the Navigate key for < 1 second. The display will show the motor Power (kW)	If P-10 > 0, pressing the Navigation key for < 1 second will display the motor speed (RPM)

5.3 CHANGING PARAMETERS

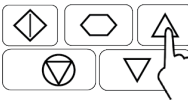
	Press and hold the Navigate button >2 seconds
	Use the UP and DOWN buttons to selected the required parameter
	Press the Navigate button for <1 second
	Adjust the value using the UP and DOWN buttons
	Press for <1 second to return to the parameter menu
	Press for >2 seconds to return to the operating display



5.4 READ ONLY PARAMETER ACCESS

	Press and hold the Navigate button >2 seconds
	Use the UP and DOWN buttons to selected the required parameter
	Press the Navigate button for <1 second
	Adjust the value using the UP and DOWN buttons
	Press for <1 second to return to the parameter menu
	Press for >2 seconds to return to the operating display

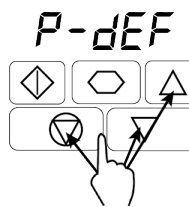
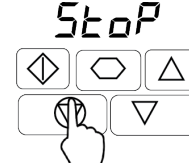
5.5 RESETTING PARAMETER

	To reset parameter values to their factory default settings, press and hold UP, DOWN and STOP buttons for >2 seconds. The display will show "P-dEF"
	Press the STOP buttons This will display "StoP"

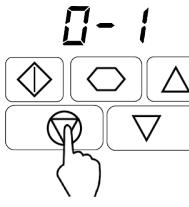
5.6 RESETTING A FAULT

	Press the STOP button. The display will show "StoP".
	

5.7 LED DISPLAY

The EDrive E3 has a built in 6-digit 7-Segment LED display. In order to display certain warning, the following methods are used.

5.7.1 LED Display Layout

See Fig 5

5.7.2 LED Display Meaning

See table below

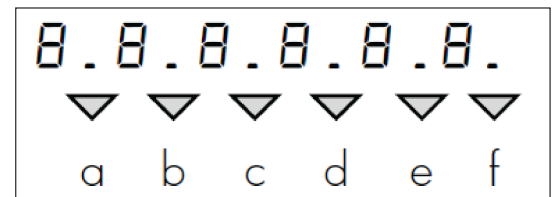

Fig 7

LED Segments	Behaviour	Meaning
a, b, c, d, e, f	Flashing all together	Overload, motor output current exceeds P-08
a and f	Flashing alternately	Mains Loss (Incoming AC power has been removed)
a	Flashing	Fire Mode Active

6. PARAMETERS

6.1 STANDARD PARAMETERS

The parameter set is arranged in Groups according to the following structure:

Parameter Group	Range	Access Level	Access Type
P00	P00-01 to P00-20	Extended	Read Only
	P00-21 to P00-50	Advanced	Read Only
Basic Parameters	P-01 to P-14	Basic	Read / Write
Extended Parameters	P-15 to P-50	Extended	Read / Write
Advanced Parameters	P-51 to P-60	Advanced	Read / Write

Access to all parameter groups is controlled by setting P-14 as follows:

P-14 = P-37 (Factory setting: 101) Allows Extended Parameter Access

P-14 = P-37 + 100 (Factory Setting: 201) Allows Advanced Parameter Access

In order to prevent possible damage to the drive and connected machinery, certain parameters are locked during operation of the drive to prevent change. In the case that the drive is enabled, and the user tries to change the parameter, an “L” is shown on the left of the display.

6.2 PARAMETER LIST

6.2.1 Standard Parameters

Par.	Function	Page No.
P-01	Maximum Frequency / Speed Limit	24
P-02	Minimum Frequency / Speed Limit	24
P-03	Acceleration Ramp Time	24
P-04	Deceleration Ramp Time	24
P-05	Stop Mode / Mains Loss Control	24
P-06	Energy Optimiser	25
P-07	Motor Rated Voltage / kE (PM / BLDC)	22
P-08	Motor Rated Current	22
P-09	Motor Rated Frequency	22
P-10	Motor Rated Speed	22
P-11	Low Frequency Torque Boost	23
P-12	Primary Command Source	24
P-13	Application Mode	24
P-14	Extended Menu Access code	26

6.2.2 Extended Parameters

Par.	Function	Page No.
P-15	Digital Input Function	28
P-16	Analog Input 1 Format	26
P-17	Effective Switching Frequency	26
P-18	Relay Output Function	27
P-19	Relay Threshold	27
P-20	Preset Frequency / Speed 1	28
P-21	Preset Frequency / Speed 2	28
P-22	Preset Frequency / Speed 3	28
P-23	Preset Frequency / Speed 4	28
P-24	Second Ramp Time	24
P-25	Analog Output Function	27
P-26	Skip Frequency Band Width	30
P-27	Skip Frequency Center Point	30
P-28	V/F Adjustment Voltage	30
P-29	V/F Adjustment Frequency	30
P-30	Start/ Restart / Fire Mode Config	29
P-31	Keypad Start Mode	29
P-32	Index 1: DC Injection Duration	31
	Index 2: DC Injection Braking Mode	31
P-33	Spin Start Enable	31
P-34	Brake Chopper Enable (Not Size 1)	31
P-35	Analog Input 1/Slave Speed Scaling	26
P-36	Communication Configuration	33
P-37	Extended Menu Access Code	28
P-38	Parameter Lock	28
P-39	Analog Input 1 Offset	26
P-40	Index 1: Display Scaling Factor	31
	Index 2: Display Scaling Source	31
P-41	PI Proportional Gain	32
P-42	PI Integral Time	32
P-43	PI Operating Mode	32
P-44	PI Reference (Setpoint) Source	32
P-45	PI Digital Reference	32
P-46	PI Feedback Source	32
P-47	Analog Input 2 Signal Format	26
P-48	Standby Mode Timer	32
P-49	PI Error Wake Up Level	32
P-50	Relay Output Hysteresis	27

6.2.3 Advanced Parameters

Par.	Function	Page No.
P-51	Motor Control Mode	34
P-52	Auto-tune Enable	34
P-53	Vector Speed Control P-gain	34
P-54	Maximum Current Limit	33
P-55	Motor Stator Resistance	34
P-56	Motor Stator Inductance (d)	34
P-57	Motor Stator Inductance (q)	34
P-58	DC Injection Frequency / Speed	31
P-59	DC Injection Current	31
P-60	Overload Management	36

6.3 PARAMETER FUNCTIONS

The following sections highlight the parameters relevant to certain functions in the drive firmware. Parameters are grouped according to the function.

6.3.1 Basic Functions

Motor Name Plate Settings (Relevant Parameters)

Par.	Description	Minimum	Maximum	Default	Units
P-07	Motor Rated Voltage / kE For Induction Motors, this parameter should be set to the rated (nameplate) voltage of the motor (Volts). For Permanent Magnet or Brushless DC Motors, it should be set to the Back EMF at rated speed.	0	250 / 500	230 / 400	V
P-08	Motor Rated Current This parameter should be set to the rated (nameplate) current of the motor.	Drive Rating Dependent			A
P-09	Motor Rated Frequency This parameter should be set to the rated (nameplate) frequency of the motor.	10	500	50 (60)	Hz

When commissioning the drive, it is necessary to enter certain information about the motor into the drive to ensure the drive is optimised to control the connected motor and additionally to prevent damage to the motor.

For standard induction motors, the parameters are listed below. For alternative motor types, refer to the later relevant sections for each motor type.

Working in RPM (Relevant Parameters)

Par.	Description	Minimum	Maximum	Default	Units
P-10	Motor Rated Speed This parameter can optionally be set to the rated (nameplate) RPM of the motor. When set to the default value of zero, all speed related parameters are displayed in Hz and the slip compensation (where motor speed is maintained at a constant value regardless of applied load) for the motor is disabled. Entering the value from the motor nameplate enables the slip compensation function, and the Optidrive display will now show motor speed in RPM. All speed related parameters, such as Minimum and Maximum Speed, Preset Speeds etc. will also be displayed in RPM. NOTE If P-09 value is changed, P-10 value is reset to 0.	0	30000	0	RPM

EDrive E3 normally uses frequency for all speed related parameters, e.g. Minimum and Maximum Output Frequency. It is also possible to work directly in RPM, by setting the above parameter to the relevant rated speed from the connected motor nameplate.

When set to the default value of zero, all speed related parameters are displayed in Hz, and slip compensation for the motor is disabled. Entering the value from the motor nameplate enables the slip compensation function, and the EDrive display will also now show motor speed in RPM. All speed related parameters, such as Minimum and Maximum Speed, Preset Speeds etc. will also be displayed in RPM.

NOTE: If P-09 value is changed, P-10 value is reset to 0.

Low Frequency Torque Boost (Relevant Parameters)

Par.	Description	Minimum	Maximum	Default	Units														
P-11	Low Frequency Torque Boost	0.0	Drive Dependent		%														
	<p>Low frequency torque can be improved by increasing this parameter. Excessive boost levels may however result in high motor current and increased risk of tripping on Over Current or Motor Overload (refer to section 11.1. Fault Code Messages).</p> <p>This parameter operates in conjunction with P-51 (Motor Control Mode) as follows:</p> <table border="1"> <thead> <tr> <th>P-51</th> <th>P-11</th> <th></th> </tr> </thead> <tbody> <tr> <td rowspan="2">0</td> <td>0</td> <td>Boost is automatically calculated according to autotune data.</td> </tr> <tr> <td>>0</td> <td>Voltage boost = $P-11 \times P-07$. This voltage is applied at 0.0Hz, and linearly reduced until $P-09 / 2$.</td> </tr> <tr> <td>1</td> <td>All</td> <td>Voltage boost = $P-11 \times P-07$. This voltage is applied at 0.0Hz, and linearly reduced until $P-09 / 2$.</td> </tr> <tr> <td>2, 3, 4</td> <td>All</td> <td>Boost current level = $4 * P-11 * P-08$.</td> </tr> </tbody> </table> <p>For IM motors, when P-51 = 0 or 1, a suitable setting can usually be found by operating the motor under very low or no load conditions at approximately 5Hz, and adjusting P-11 until the motor current is approximately the magnetising current (if known) or in the range shown below.</p> <p>Frame Size 1: 60 – 80% of motor rated current. Frame Size 2: 50 – 60% of motor rated current. Frame Size 3: 40 – 50% of motor rated current. Frame Size 4: 35 – 45% of motor rated current.</p>					P-51	P-11		0	0	Boost is automatically calculated according to autotune data.	>0	Voltage boost = $P-11 \times P-07$. This voltage is applied at 0.0Hz, and linearly reduced until $P-09 / 2$.	1	All	Voltage boost = $P-11 \times P-07$. This voltage is applied at 0.0Hz, and linearly reduced until $P-09 / 2$.	2, 3, 4	All	Boost current level = $4 * P-11 * P-08$.
P-51	P-11																		
0	0	Boost is automatically calculated according to autotune data.																	
	>0	Voltage boost = $P-11 \times P-07$. This voltage is applied at 0.0Hz, and linearly reduced until $P-09 / 2$.																	
1	All	Voltage boost = $P-11 \times P-07$. This voltage is applied at 0.0Hz, and linearly reduced until $P-09 / 2$.																	
2, 3, 4	All	Boost current level = $4 * P-11 * P-08$.																	

Low Frequency Torque Boost is used to increase the applied motor voltage and hence current at low output frequencies. This can improve low speed and starting torque. Increasing the boost level will increase motor current at low speed, which may result in the motor temperature rising - force ventilation or additional cooling of the motor may then be required. In general, the lower the motor power, the higher the boost setting that may be safely used.

For IM motor types (P-51 = 0 or 1), the value entered determines the voltage applied to the motor at 0.0Hz relative to P-07 setting. e.g.

- P-07 = 400V
- P-11 = 2%
- Output voltage applied to the motor at 0.0Hz = 2% x 400V = 8V.

This boost voltage is then linearly reduced up to 50% of the motor rated speed (P-09).

When operating with alternative motor types (P-51 = 2, 3 or 4) this parameter is used to set an additional boost current which is injected into the motor. The actual current level is defined as $4 * P-11 * P-08$.

This additional current is injected between 0.0Hz and 10% of rated frequency. Above this point, the boost current is reduced according to the diagram below.

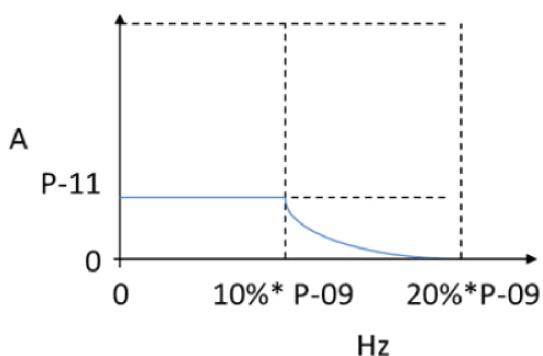

Speed Limits (Relevant Parameters)

These parameters define the range of output frequency and therefore the speed range through which the drive will operate. As described above:

- If P-10 = 0, Values are Hz
- If P-10 <> 0, Values are RPM

Dependent on the speed reference selection, the operation will be as follows:

For Analog Speed Reference: Applying 0% analog signal results in the speed reference of P-02. Applying 100% signal results in the speed reference of P-01. Scaling between these points is linear.

Scaling may be adjusted on Analog Input 1 only using the AI1 Scaling & Offset function shown on page 26.

The value used for the speed reference:

Par.	Description	Minimum	Maximum	Default	Units
P-01	Maximum Frequency / Speed Limit	P-02	500.0	50.0 (60.0)	Hz / RPM
	Maximum output frequency or motor speed limit – Hz or RPM. If P-10 >0, the value entered / displayed is in RPM.				
P-02	Minimum Frequency / Speed Limit	0.0	P-01	20.0	Hz / RPM
	Minimum speed limit – Hz or RPM. If P-10 >0, the value entered / displayed is in RPM.				

Acceleration and Deceleration (Relevant Parameters)

Par.	Description	Minimum	Maximum	Default	Units
P-03	Acceleration Ramp Time	0.00	600.0	5.0	s
	Acceleration ramp time from zero Hz / RPM to base frequency (P-09) in seconds.				
P-04	Deceleration Ramp Time	0.00	600.0	5.0	s
	Deceleration ramp time from base frequency (P-09) to standstill in seconds. When set to 0.00, the value of P-24 is used.				

Second Deceleration Time (Relevant Parameters)

Par.	Description	Minimum	Maximum	Default	Units
P-24	Second Ramp Time (Fast Stop)	0.00	6000.0	0.0	s
	This parameter allows an alternative deceleration ramp down time to be programmed into the Optidrive, which can be selected by digital inputs (dependent on the setting of P-15) or selected automatically in the case of a mains power loss if P-05 = 2 or 3. When set to 0.00, the drive will coast to stop.				

Stopping Mode (Relevant Parameters)

Par.	Description	Minimum	Maximum	Default	Units
P-05	Stop Mode / Mains Loss Control	0	3	0	-
	Selects the stopping mode of the drive, and the behaviour in response to a loss of mains power supply during operation.				
	Setting	On Disable	On Mains Loss		
	0	Ramp to Stop (P-04)	Ride Through (Recover energy from load to maintain operation)		
	1	Coast	Coast		
	2	Ramp to Stop (P-04)	Fast Ramp to Stop (P-24), Coast if P-24 = 0		
	3	Ramp to Stop (P-04) with AC Flux Braking	Fast Ramp to Stop (P-24), Coast if P-24 = 0		
4	Ramp to Stop (P-04)	No action			

Energy Optimizer

This parameter configures the energy saving functions of the drive as follows:

Motor Energy Optimisation: Reduces energy losses in the motor under part load conditions by reducing motor flux. This function should not be used in applications which have large sudden load step changes, or for PI control applications, as it may cause instability in the control or over current trip.

Drive Energy Optimiser: Reduces the energy losses in the drive at higher output frequencies by reducing switching losses. This may lead to vibration or instability in the motor under light load conditions.

Par.	Description	Minimum	Maximum	Default	Units
P-06	Energy Optimiser	0	4	0	-
	Setting	Motor Energy Optimiser		Drive Energy Optimiser	
	0	Disabled		Disabled	
	1	Enabled		Disabled	
	2	Disabled		Enabled	
	3	Enabled		Enabled	

Application Macros (Relevant Parameters)

Par.	Description	Minimum	Maximum	Default	Units	
P-13	Application Mode	0	2	0	-	
	Provides a quick set up to configure key parameters according to the intended application of the drive. Parameters are preset according to the table. 0: Industrial Mode. Intended for general purpose applications. 1: Pump Mode. Intended for centrifugal pump applications. 2: Fan Mode. Intended for Fan applications.					
	Setting	Application	Current Limit (P-54)	Torque Characteristic	Spin Start (P-33)	Thermal Overload Limit Reaction (P-60 Index 2)
	0	General	150%	Constant	0: Off	0: Trip
	1	Pump	110%	Variable	0: Off	1: Current Limit Reduction
	2	Fan	110%	Variable	2: On	1: Current Limit Reduction

6.3.2 Control Modes

Par.	Description	Minimum	Maximum	Default	Units
P-12	Primary Command Source	0	9	0	-
	0: Terminal control. The drive responds directly to signals applied to the control terminals.				
	1: Keypad control - uni-directional. The drive can be controlled in the forward direction only using the internal keypad, or an external remote Keypad.				
	2: Keypad control - bi-directional. The drive can be controlled in the forward and reverse directions using the internal keypad, or an external remote Keypad. Pressing the keypad START button toggles between forward and reverse.				
	3: Modbus RTU control with internal ramps active. Control via Modbus RTU (RS485) using the internal Accel / Decel ramps.				
	4: Modbus RTU control with internal ramps inactive. Control via Modbus RTU (RS485) interface with Accel / Decel ramps updated via Modbus.				
	5: PI control. User PI control with external feedback signal.				
	6: PI control added to analog input 1. PI control with external feedback signal and summation with analog input 1.				
	7: CANopen control with internal ramps active. Control via CAN (RS485) using the internal Accel / Decel ramps.				
	8: CANopen control with internal ramps inactive. Control via CAN (RS485) interface with Accel / Decel ramps updated via CAN.				
9: Slave mode. Control via a connected Invertek drive in Master Mode. Slave drive address must be > 1.					
NOTE When P-12 = 1, 2, 3, 4, 7, 8 or 9, an enable signal must still be provided at the control terminals, digital input 1.					

6.3.3 Input and Output Functions

Analog Inputs - Format (Relevant Parameters)

Par.	Description	Minimum	Maximum	Default	Units
P-16	Analog Input 1 Format	See Below		In-pot	-
	<p>U 0- 10 = Uni-polar 0 to 10 Volt Signal. The drive will remain at minimum speed (P-02) if the analog reference after scaling and offset are applied is $\leq 0.0\%$. 100% signal means the output frequency / speed will be the value set in P-01.</p> <p>b 0- 10 = Uni-polar 0 to 10 Volt Signal, bi-directional operation. The drive will operate the motor in the reverse direction of rotation if the analog reference after scaling and offset are applied is $\leq 0.0\%$. E.g. for bidirectional control from a 0 – 10 volt signal, set P-35 = 200.0%, P-39 = 50.0%.</p> <p>A 0- 20 = 0 to 20mA Signal.</p> <p>t 4- 20 = 4 to 20mA Signal, the Optidrive will trip and show the fault code 4- 20F if the signal level falls below 3mA.</p> <p>r 4- 20 = 4 to 20mA Signal, the Optidrive will run at Preset Speed 1 (P-20) if the signal level falls below 3mA.</p> <p>t 20- 4 = 20 to 4mA Signal, the Optidrive will trip and show the fault code 4- 20F if the signal level falls below 3mA.</p> <p>r 20- 4 = 20 to 4mA Signal, the Optidrive will run at Preset Speed 1 (P-20) if the signal level falls below 3mA.</p> <p>U 10- 0 = 10 to 0 Volt Signal (Uni-polar). The drive will operate at Maximum Frequency / Speed if the analog reference after scaling and offset are applied is $\leq 0.0\%$.</p> <p>In-Pot = Integrated Potentiometer.</p>				
P-17	Effective Switching Frequency	4	32	8	kHz
	Sets maximum effective switching frequency of the drive. If "rEd" is displayed when the parameter is viewed, the switching frequency has been reduced to the level in P00-32 due to excessive drive heatsink temperature.				
P-47	Analog Input 2 Format	-	-	U0-10-	-
	<p>U 0- 10 = 0 to 10 Volt Signal.</p> <p>A 0- 20 = 0 to 20mA Signal.</p> <p>t 4- 20 = 4 to 20mA Signal, the Optidrive will trip and show the fault code 4- 20F if the signal level falls below 3mA.</p> <p>r 4- 20 = 4 to 20mA Signal, the Optidrive will run at Preset Speed 1 (P-20) if the signal level falls below 3mA.</p> <p>t 20- 4 = 20 to 4mA Signal, the Optidrive will trip and show the fault code 4- 20F if the signal level falls below 3mA.</p> <p>r 20- 4 = 20 to 4mA Signal, the Optidrive will run at Preset Speed 1 (P-20) if the signal level falls below 3mA.</p> <p>Ptc-tk = Use for motor thermistor measurement, valid with any setting of P-15 that has Input 3 as E-Trip. Trip level: 1.5kΩ, reset 1kΩ.</p>				

Analog Inputs - AI1 Scaling & Offset (Relevant Parameters)

Par.	Description	Minimum	Maximum	Default	Units
P-35	Analog Input 1/ Slave Speed Scaling	0.0	2000.0	100.0	%
	<p>Analog Input 1 Scaling. The analog input signal level is multiplied by this factor, e.g. if P-16 is set for a 0 – 10V signal, and the scaling factor is set to 200.0%, a 5 volt input will result in the drive running at maximum frequency / speed (P-01).</p> <p>Slave Speed Scaling. When operating in Slave Mode (P-12 = 9), the operating speed of the drive will be the Master speed multiplied by this factor, limited by the minimum and maximum speeds.</p>				
P-39	Analog Input 1 Offset	-500.0	500.0	0.0	%
	<p>Sets an offset, as a percentage of the full scale range of the input, which is applied to the analog input signal. This parameter operates in conjunction with P-35, and the resultant value can be displayed in P00-01.</p> <p>The resultant value is defined as a percentage, according to the following: $P00-01 = (\text{Applied Signal Level}(\%) - P-39) \times P-35$.</p>				

Relay Output Functions (Relevant Parameters)

Par.	Description	Minimum	Maximum	Default	Units
P-18	Relay Output Function	0	9	1	-
	Selects the function assigned to the relay output. The relay has two output terminals, Logic 1 indicates the relay is active, and therefore terminals 10 and 11 will be connected. 0: Drive running. Logic 1 when the motor is enabled. 1: Drive healthy. Logic 1 when power is applied to the drive and no fault exists. 2: At speed. Logic 1 when the output frequency matches the setpoint frequency. 3: Drive tripped. Logic 1 when the drive is in a fault condition. 4: Motor speed >= limit. Logic 1 when the output frequency exceeds the adjustable limit set in P-19. 5: Motor current >=limit. Logic 1 when the motor current exceeds the adjustable limit set in P-19. 6: Motor speed <limit. Logic 1 when the output frequency is below the adjustable limit set in P-19. 7: Motor current <limit. Logic 1 when the motor current is below the adjustable limit set in P-19. 8: Analog input 2 >=limit. Logic 1 when the signal applied to analog input 2 exceeds the adjustable limit set in P-19. 9: Drive ready to run. Logic 1 when the drive is ready to run, no trip present.				
P-19	Relay Threshold	0.0	200.0	100.0	%
	Adjustable threshold level used in conjunction with settings 4 to 8 of P-18.				
P-50	Relay Output Hysteresis	0.0	100.0	0.0	%
	Sets the hysteresis level for P-19 to prevent the output relay chattering when close to the threshold.				

Analog Output Functions (Relevant Parameters)

Par.	Description	Minimum	Maximum	Default	Units
P-25	Analog Output Function	0	11	8	-
	Digital Output Mode. Logic 1 = +24V DC 0: Drive running. Logic 1 when the Optidrive is enabled (Running). 1: Drive healthy. Logic 1 When no Fault condition exists on the drive. 2: At speed. Logic 1 when the output frequency matches the setpoint frequency. 3: Drive tripped. Logic 1 when the drive is in a fault condition. 4: Motor speed >= limit. Logic 1 when the output frequency exceeds the adjustable limit set in P-19. 5: Motor current >=limit. Logic 1 when the motor current exceeds the adjustable limit set in P-19. 6: Motor speed <limit. Logic 1 when the output frequency is below the adjustable limit set in P-19. 7: Motor current <limit. Logic 1 when the motor current is below the adjustable limit set in P-19. Analog Output Mode 8: Motor speed. 0 to P-01, resolution 0.1Hz. 9: Motor current. 0 to 200% of P-08, resolution 0.1A. 10: Motor power. 0 – 200% of drive rated power. 11: Motor torque. 0 – 200% of P-08, resolution 0.1A.				
P-19	Relay Threshold	0.0	200.0	100.0	%
	Adjustable threshold level used in conjunction with settings 4 to 8 of P-25.				

6.3.4 Common Functions

Parameter Access Control & Locking (Relevant Parameters)

Par.	Description	Minimum	Maximum	Default	Units
P-14	Extended Menu Access	0	65535	0	-
	Enables access to Extended and Advanced Parameter Groups. This parameter must be set to the value programmed in P-37 (default: 101) to view and adjust Extended Parameters and value of P-37 + 100 to view and adjust Advanced Parameters. The code may be changed by the user in P-37 if desired.				
P-37	Extended Menu Access Code	0	9999	101	-
	Defines the access code which must be entered in P-14 to access parameters above P-14.				
P-38	Parameter Lock	0	1	0	-
	0: Unlocked. All parameters can be accessed and changed. 1: Locked. Parameter values can be displayed, but cannot be changed except P-38.				

Local/Remote (Relevant Parameters)

Par.	Description	Minimum	Maximum	Default	Units
P-15	Digital Input Function	0	17	0	-
	Defines the function of the digital inputs depending on the control mode setting in P-12. See section 7. Analog and Digital Input Macro Configurations for more information.				

Preset Speeds (Relevant Parameters)

Par.	Description	Minimum	Maximum	Default	Units
P-15	Digital Input Function Select	0	17	0	-
	Defines the function of the digital inputs depending on the control mode setting in P-12. See section 7. Analog and Digital Input Macro Configurations for more information.				
P-20	Preset Frequency / Speed 1	-P-01	P-01	5.0	Hz / RPM
P-21	Preset Frequency / Speed 2	-P-01	P-01	25.0	Hz / RPM
P-22	Preset Frequency / Speed 3	-P-01	P-01	40.0	Hz / RPM
P-23	Preset Frequency / Speed 4	-P-01	P-01	P-09	Hz / RPM
	Preset Speeds / Frequencies selected by digital inputs depending on the setting of P-15. If P-10 = 0, the values are entered as Hz. If P-10 > 0, the values are entered as RPM. NOTE Changing the value of P-09 will reset all values to factory default settings.				

Start Mode, Auto Restart and Fire Mode (Relevant Parameters)

Par.	Description	Minimum	Maximum	Default	Units
P-15	Digital Input Function	0	17	0	-
	Defines the function of the digital inputs depending on the control mode setting in P-12. See section 7. Analog and Digital Input Macro Configurations for more information.				

Par.	Description	Minimum	Maximum	Default	Units
P-25	Analog Output Function	0	11	8	-
	<p>Digital Output Mode. Logic 1 = +24V DC</p> <p>0: Drive running. Logic 1 when the Optidrive is enabled (Running).</p> <p>1: Drive healthy. Logic 1 When no Fault condition exists on the drive.</p> <p>2: At speed. Logic 1 when the output frequency matches the setpoint frequency.</p> <p>3: Drive tripped. Logic 1 when the drive is in a fault condition.</p> <p>4: Motor speed >= limit. Logic 1 when the output frequency exceeds the adjustable limit set in P-19.</p> <p>5: Motor current >=limit. Logic 1 when the motor current exceeds the adjustable limit set in P-19.</p> <p>6: Motor speed <limit. Logic 1 when the output frequency is below the adjustable limit set in P-19.</p> <p>7: Motor current <limit. Logic 1 when the motor current is below the adjustable limit set in P-19.</p> <p>Analog Output Mode</p> <p>8: Motor speed. 0 to P-01, resolution 0.1Hz.</p> <p>9: Motor current. 0 to 200% of P-08, resolution 0.1A.</p> <p>10: Motor power. 0 – 200% of drive rated power.</p> <p>11: Motor torque. 0 – 200% of P-08, resolution 0.1A.</p>				
P-30	Start/ Restart / Fire Mode Configuration				
	Index 1: Start Mode / Auto Restart	N/A	N/A	Edge-r	-
	<p>Selects whether the drive should start automatically if the enable input is present and latched during power on. Also configures the Automatic Restart function.</p> <p><i>EdgE-r</i>: Following Power on or reset, the drive will not start if Digital Input 1 remains closed. The Input must be closed after a power on or reset to start the drive.</p> <p><i>RUtO-0</i>: Following a Power On or Reset, the drive will automatically start if Digital Input 1 is closed.</p> <p><i>RUtO-1</i> To <i>RUtO-5</i>: Following a trip, the drive will make up to 5 attempts to restart at 20 second intervals. The numbers of restart attempts are counted, and if the drive fails to start on the final attempt, the drive will trip with a fault, and will require the user to manually reset the fault. The drive must be powered down to reset the counter.</p>				
	Index 2: Fire Mode Input Logic	0	1	0	-
	<p>Defines the operating logic when a setting of P-15 is used which includes Fire Mode, e.g. settings 15, 16, 17 & 18.</p> <p>0: Normally Closed (NC) input. Fire Mode active if input is open.</p> <p>1: Normally Open (NO) input. Fire Mode active if input is closed.</p>				
P-31	Index 3: Fire Mode Input Latch	0	1	0	-
	<p>Defines the input type when a setting of P-15 is used which includes Fire Mode, e.g. settings 15, 16, 17 & 18.</p> <p>0: Latched input. The drive will remain in Fire Mode, only as long the fire mode input signal remains (Normally Open or Normally Closed operation is supported depending on Index 2 setting).</p> <p>1: Momentary input. Fire Mode is activated by a momentary signal on the input. Normally Open or Normally Closed operation is supported depending on Index 2 setting. The drive will remain in Fire Mode until disabled or powered off.</p>				
P-31	Keypad Start Mode	0	7	1	-
<p>This parameter is active only when operating in Keypad Control Mode (P-12 = 1 or 2) or Modbus Mode (P-12 = 3 or 4). When settings 0, 1, 4 or 5 are used, the Keypad Start and Stop keys are active, and control terminals 1 and 2 must be linked together. Settings 2, 3, 6 and 7 allow the drive to be started from the control terminals directly, and the keypad Start and Stop keys are ignored.</p> <p>0: Minimum speed, keypad start</p> <p>1: Previous speed, keypad start</p> <p>2: Minimum speed, terminal start</p> <p>3: Previous speed, terminal start</p> <p>4: Current speed, keypad start</p> <p>5: Preset speed 4, keypad start</p> <p>6: Current speed, terminal start</p> <p>7: Preset speed 4, terminal start</p>					

The Fire Mode function is designed to ensure continuous operation of the drive in emergency conditions until the drive is no longer capable of sustaining operation. The Fire Mode input may be a normally open (Close to Activate Fire Mode) or Normally Closed (Open to Activate Fire Mode) according to the setting of P-30 Index 2. In addition, the input may be momentary or maintained type, selected by P-30 Index 3.

This input may be linked to a fire control system to allow maintained operation in emergency conditions, e.g. to clear smoke or maintain air quality within that building.

The fire mode function is enabled when P-15 = 15, 16, 17 or 18, with Digital Input 3 assigned to activate fire mode.

Fire Mode disables the following protection features in the drive:

- O-t Heat-sink Over-Temperature
- U-t Drive Under Temperature
- Th-FLt Faulty Thermistor on Heat-sink
- E-trip External Trip
- 4-20 F 4-20mA fault
- Ph-lb Phase Imbalance
- P-Loss Input Phase Loss Trip
- SC-trp Communications Loss Trip
- It-trp Accumulated overload Trip
- Out-F Drive output fault, Output stage trip

The following faults will result in a drive trip, auto reset and restart:

- O-Volt Over Voltage on DC Bus
- U-Volt Under Voltage on DC Bus
- h O-I Fast Over-current Trip
- O-I Instantaneous over current on drive output

Switching Frequency Selection (Relevant Parameters)

Par.	Description	Minimum	Maximum	Default	Units
P-17	Effective Switching Frequency	4	32	8	kHz
Sets maximum effective switching frequency of the drive. If "rEd" is displayed when the parameter is viewed, the switching frequency has been reduced to the level in P00-32 due to excessive drive heatsink temperature.					

Skip Frequency (Relevant Parameters)

Par.	Description	Minimum	Maximum	Default	Units
P-26	Skip Frequency Band Width	0.0	P-01	0.0	Hz / RPM
P-27	Skip Frequency Center Point	0.0	P-01	0.0	Hz / RPM
The Skip Frequency function is used to avoid the Optidrive operating at a certain output frequency, for example at a frequency which causes mechanical resonance in a particular machine. Parameter P-27 defines the centre point of the skip frequency band, and is used in conjunction with P-26. The Optidrive output frequency will ramp through the defined band at the rates set in P-03 and P-04 respectively, and will not hold any output frequency within the defined band. If the frequency reference applied to the drive is within the band, the Optidrive output frequency will remain at the upper or lower limit of the band.					

V / F Characteristics Adjustment (Relevant Parameters)

Par.	Description	Minimum	Maximum	Default	Units
P-28	V/F Characteristic Adjustment Voltage	0	P-07	0	V
P-29	V/F Characteristic Adjustment Voltage	0.0	P-09	0.0	Hz
This parameter in conjunction with P-28 sets a frequency point at which the voltage set in P-29 is applied to the motor. Care must be taken to avoid overheating and damaging the motor when using this feature.					

DC Injection Braking (Relevant Parameters)

Par.	Description	Minimum	Maximum	Default	Units
P-32	Index 1: DC Injection Duration	0.0	25.0	0.0	s
	Index 2: DC Injection Braking Mode	0	2	0	-
Determined by Autotune, adjustment is not normally required.					
P-58	DC Injection Frequency / Speed	0.0	P-01	0.0	Hz / RPM
Sets the speed at which DC injection current is applied during braking to Stop, allowing DC to be injected before the drive reaches zero speed if desired.					
P-59	DC Injection Current	0.0	100.0	20.0	%
Sets the level of DC injection braking current applied according to the conditions set in P-32 and P-58.					

Spin Start (Relevant Parameters)

Par.	Description	Minimum	Maximum	Default	Units
P-33	Spin Start Enable	0	2	0	-
0: Disabled 1: Enabled. When enabled, on start up the drive will attempt to determine if the motor is already rotating, and will begin to control the motor from its current speed. A short delay may be observed when starting motors which are not turning. 2: Enabled on Trip, Brown Out or Coast Stop. Spin start is only activated following the events listed, otherwise it is disabled.					

Dynamic braking (Relevant Parameters)

Par.	Description	Minimum	Maximum	Default	Units
P-34	Brake Chopper Enable (Not Size 1)	0	4	0	-
0: Disabled 1: Enabled with software protection. Brake chopper enabled with software protection for a 200W continuous rated resistor. 2: Enabled without software protection. Enables the internal brake chopper without software protection. An external thermal protection device should be fitted. 3: Enabled with software protection on speed change only. As setting 1, however the Brake Chopper is only enabled during a change of the frequency setpoint, and is disabled during constant speed operation. 4: Enabled without software protection on speed change only. As setting 2, however the Brake Chopper is only enabled during a change of the frequency setpoint, and is disabled during constant speed operation.					

Display Scaling (Relevant Parameters)

Par.	Description	Minimum	Maximum	Default	Units
P-40	Index 1: Display Scaling Control	0.000	16.000	0.000	-
	Index 2: Display Scaling Source	0	3	0	-
Allows the user to program the Optidrive to display an alternative output unit scaled from either output frequency (Hz), Motor Speed (RPM) or the signal level of PI feedback when operating in PI Mode.					
Index 1: Used to set the scaling multiplier. The chosen source value is multiplied by this factor.					
Index 2: Defines the scaling source as follows:					
0: Motor Speed. Scaling is applied to the output frequency if P-10 = 0, or motor RPM if P-10 > 0.					
1: Motor Current. Scaling is applied to the motor current value (Amps).					
2: Analog Input 2 Signal Level. Scaling is applied to analog input 2 signal level, internally represented as 0 – 100.0%.					
3: PI Feedback. Scaling is applied to the PI feedback selected by P-46, internally represented as 0 – 100.0%.					

PI Control (Relevant Parameters)

Par.	Description	Minimum	Maximum	Default	Units
P-41	PI Proportional Gain	0.0	30.0	1.0	-
	PI Controller Proportional Gain. Higher values provide a greater change in the drive output frequency in response to small changes in the feedback signal. Too high a value can cause instability.				
P-42	PI Integral Time	0.0	30.0	1.0	s
	PI Controller Integral Time. Larger values provide a more damped response for systems where the overall process responds slowly.				
P-43	PI Operating Mode	0	1	0	-
	<p>0: Direct Operation. Use this mode if when the feedback signal drops, the motor speed should increase.</p> <p>1: Inverse Operation. Use this mode if when the feedback signal drops, the motor speed should decrease.</p> <p>2: Direct Operation, Wake at Full Speed. As setting 0, but on restart from Standby, PI Output is set to 100%.</p> <p>3: Reverse Operation, Wake at Full Speed. As setting 0, but on restart from Standby, PI Output is set to 100%.</p>				
P-44	PI Reference (Setpoint) Source	0	1	0	-
	<p>Selects the source for the PI Reference / Setpoint.</p> <p>0: Digital Preset. P-45 is used.</p> <p>1: Analog Input 1. Analog input 1 signal level, readable in P00-01 is used for the setpoint.</p>				
P-45	PI Digital Reference	0.0	100.0	0.0	%
	When P-44 = 0, this parameter sets the preset digital reference (setpoint) used for the PI Controller as a % of the feedback signal.				
P-46	PI Feedback Source	0	5	0	-
	<p>Selects the source of the feedback signal to be used by the PI controller.</p> <p>0: Analog Input 2 (Terminal 4) Signal level readable in P00-02.</p> <p>1: Analog Input 1 (Terminal 6) Signal level readable in P00-01.</p> <p>2: Motor Current Scaled as % of P-08.</p> <p>3: DC Bus Voltage Scaled 0 – 1000 Volts = 0 – 100%.</p> <p>4: Analog 1 – Analog 2 The value of Analog Input 2 is subtracted from Analog 1 to give a differential signal. The minimum value is 0.</p> <p>5: Largest (Analog 1, Analog 2) The larger of the two analog input values is always used for PI feedback.</p>				

Standby Mode & Wake Up (Relevant Parameters)

Par.	Description	Minimum	Maximum	Default	Units
P-48	Standby Mode Timer	0.0	25.0	0.0	s
	When standby mode is enabled by setting P-48 > 0.0, the drive will enter standby following a period of operating at minimum speed (P-02) for the time set in P-48. When in Standby Mode, the drive display shows Standby , and the output to the motor is disabled.				
P-49	PI Error Wake Up Level	0.0	100.0	5.0	%
	When the drive is operating in PI Control Mode (P-12 = 5 or 6), and Standby Mode is enabled (P-48 > 0.0), P-49 can be used to define the PI Error Level (E.g. difference between the setpoint and feedback) required before the drive restarts after entering Standby Mode. This allows the drive to ignore small feedback errors and remain in Standby mode until the feedback drops sufficiently.				

Serial Communication Configuration (Relevant Parameters)

Par.	Description	Minimum	Maximum	Default	Units
P-36	Serial Communications Configuration	See Below			
	Index 1 : Drive Address	1	63	1	-
	Index 2 : Comms Type & Baud Rate	9.6	1000	115.2	kbps
	Index 3 : Communication Loss Timeout	0	60000	300	ms
This parameter has three sub settings used to configure the Modbus RTU Serial Communications. The Sub Parameters are:					
Index 1 : Drive Address : Range : 0 – 63, default : 1					
Index 2: Comms Type & Baud Rate: Selects the Baud Rate and network type for the internal RS485 communication port. For Modbus RTU: Baud rates 9.6, 19.2, 38.4, 57.6, 115.2 kbps are available. For CAN: Baud rates 125, 250, 500 & 1000 kbps are available.					
Index 3: Communication Loss Timeout: Defines the time for which the drive will operate without receiving a valid command telegram after the drive has been enabled. This applies to Modbus RTU networks and Optibus networks (e.g. keypad control or Master Slave operation) only. CAN communication loss function is enabled via CAN objects 100Ch and 100Dh. Setting 0 disables the Watchdog timer. Setting a value of 30, 100, 1000, or 3000 defines the time limit in milliseconds for operation. A 't' suffix selects trip on loss of communication. An 'r' suffix means that the drive will coast stop (output immediately disabled) but will not trip.					

Current Limit (Relevant Parameters)

Par.	Description	Minimum	Maximum	Default	Units
P-54	Maximum Current Limit	0.0	175.0	150.0	%
Defines the max current limit in vector control modes					

6.3.4 Advanced Functions

Autotune (Relevant Parameters)

Par.	Description	Minimum	Maximum	Default	Units
P-52	Motor Parameter Autotune	0	1	0	-
<p>0: Disabled</p> <p>1: Enabled. When enabled, the drive immediately measures required data from the motor for optimal operation. Ensure all motor related parameters are correctly set first before enabling this parameter.</p> <p>This parameter can be used to optimise the performance when P-51 = 0.</p> <p>Autotune is not required if P-51 = 1.</p> <p>For settings 2 – 5 of P-51, autotune MUST be carried out AFTER all other required motor settings are entered.</p>					

Motor Control Methods

EDrive E3 may be used with the following motor types:

- A synchronous Induction Motors (IM)
- S ynchronous Permanent Magnet AC Motors (PM)
- Brushless DC Motors (BLDC)
- S ynchronous Reluctance Motors (SynRM)
- Line Start Permanent Magnet Motors (LSPM)

Each motor type requires the correct operating mode to be selected and the correct commissioning procedure to be followed as described in the following sections.

Parameters (Relevant Parameters)

Par.	Description	Minimum	Maximum	Default	Units
P-07	Motor Rated Voltage / kE	0	250 / 500	230 / 400	V
	For Induction Motors, this parameter should be set to the rated (nameplate) voltage of the motor (Volts). For Permanent Magnet or Brushless DC Motors, it should be set to the Back EMF at rated speed.				
P-08	Motor Rated Current	Drive Rating Dependent			A
	This parameter should be set to the rated (nameplate) current of the motor. This parameter cannot be adjusted greater than the continuous current rating of the drive. When the motor nameplate value is entered, thermal overload protection is enabled.				
P-09	Motor Rated Frequency	10	500	50 (60)	Hz
	This parameter should be set to the rated (nameplate) frequency of the motor.				
P-51	Motor Control Mode	0	5	0	-
	0: Induction Motor, vector speed control 1: Induction Motor, V/F mode 2: PM motor, vector speed control 3: BLDC motor, vector speed control 4: Syn RM motor, vector speed control 5: LSPM motor, vector speed control				
P-52	Motor Parameter Auto-tune Enable	0	1	0	-
	This parameter can be used to optimise the performance when P-51 = 0. Autotune is not required if P-51 = 1. For settings 2 – 5 of P-51, autotune MUST be carried out AFTER all other required motor settings are entered. 0: Disabled 1: Enabled. When enabled, the drive immediately measures required data from the motor for optimal operation. Ensure all motor related parameters are correctly set first before enabling this parameter.				
P-53	Vector Speed Control P-gain	0.0	200.0	50.0	%
	Single Parameter for Vector speed loop tuning. Affects P & I terms simultaneously. Not active when P-51 = 1.				
P-55	Motor Stator Resistance	0.00	655.35	-	Ω
	Motor stator resistance in Ohms. Determined by Autotune, adjustment is not normally required.				
P-56	Motor Stator Inductance (d)	0.00	655.35	-	mH
	Determined by Autotune, adjustment is not normally required.				
P-57	Motor Stator Inductance (q)	0.00	655.35	-	mH
	Determined by Autotune, adjustment is not normally required.				

Asynchronous Induction Motors (IM) Vector Control

EDrive E3 factory default parameters are intended for use with IM motors where the power rating of the motor is approximately the same or slightly less than the indicated power rating of the drive. In this case, it should be possible to operate the motor without any parameter adjustment at all for initial testing.

For optimum performance, the drive parameters should be adjusted to match the motor ratings. This will also ensure correct protection of the motor from damage due to overload.

The basic parameters that should be adjusted are:

- P-07 : Motor Rated Voltage (V)
- P-08 : Motor Rated Current (A)
- P-09 : Motor Rated Frequency (Hz)

In addition, it is also possible to set:

- P-10 : Motor Rated Speed (RPM)

When this parameter is adjusted, slip compensation is activated. Slip compensation attempts to compensate the motor speed relative to the load applied, such that when operating at a constant speed with different loads, the motor shaft speed should remain approximately the same.

To further improve the performance of the motor, the following additional steps can be followed:

- Carry out an Autotune.
 - This requires Advanced Parameter Access, $P-14 = P-37 + 100$ (Default : 201).
 - After the correct nameplate information is entered from the motor, the drive can additionally measure some electrical characteristics of the motor to further optimise the motor control to suit connected motor.
 - This is achieved by setting $P-52 = 1$.

The autotune will begin **IMMEDIATELY** following the setting of this parameter!

- The drive output will be enabled, and the motor shaft may move. It is important to ensure this is safe before carrying out the autotune.
- For IM motors, the autotune takes only a few seconds, and measures only the motor stator resistance. Parameter P-55 will be updated with the new value.
- Adjust the Low Frequency Torque Boost
 - IM motors require some additional voltage at low frequency to improve the low speed operation and torque.
 - By adjusting P-11, it is possible to optimise the low speed operation.
 - If P-11 is increased too far, excessive motor heating or over current trips may result.
- Speed regulation and response to load changes may be improved by adjusting P-11 Vector Gain to suit the motor and connected load.
 - Higher values will provide a more dynamic behaviour at the risk of instability.

Synchronous Permanent Magnet AC Motors (PM), BLDC Motors and LSPM Motors

Suitable Motors

EDrive E3 provides open loop control of permanent magnet AC motors including BLDC and LSPM type, intended to allow the use of high efficiency motors in simple applications. Both interior and exterior magnets type motors are supported.

Operation is permitted with motors meeting the following criteria:

- The motor Back EMF is ≥ 1 V / Hz.
 - **NOTE** Operation of motors with < 1 V/Hz Back EMF ratio may be possible with reduced speed range.
- Maximum motor frequency 360Hz.
- RMS Back EMF must not exceed the AC supply voltage during motor operation.
 - **Warning!** If the peak Back EMF exceeds 800V, the drive may be permanently damaged!

Commissioning Procedure

When operating with permanent magnet motors, the commissioning steps are as follows:

- Enter the motor Back EMF at Rated Frequency / Speed in parameter P-07.
 - This parameter must not be set to the rated motor voltage, but the actual Back EMF imposed by the motor magnets at the drive output terminals.
 - It is sometimes necessary to derive this information from a voltage constant and the rated operating speed, e.g.
- If a motor has rated speed 2500RPM, back EMF constant 80V / 1000 RPM, $P-07 = (2500 * 80) / 1000 = 200V$.
- Alternatively, obtain the value from the motor supplier, or by direct measurement using an oscilloscope.
- Enter the Motor Rated Current in P-08.
 - It is possible that excessive current levels may permanently damage the motor, therefore this parameter must be set correctly to ensure this cannot occur.
 - Additionally, this current level is used by the autotune to determine the correct inductance values.
- Enter the motor rated frequency in P-09.
- Optionally enter the motor rated speed in P-10.
- Enabled Advanced Parameter Access by setting $P-14 = P-37 + 100$ (Default : 201).

- Select the appropriate motor type in P-51
 - For PM motor control P-51 = 2
 - For BLDC motor control P-51 = 3
 - For LSPM motor control P-51 = 5
- Carry out an Autotune.
 - An Autotune MUST be carried out.
 - This is achieved by setting P-52 = 1.
 - The autotune will begin IMMEDIATELY following the setting of this parameter! The drive output will be enabled, and the motor shaft may move. It is important to ensure this is safe before carrying out the autotune.
 - For PM motors, the autotune measures the motor stator resistance and both Q and D axis inductance values. Parameters P-55, P-56 and P-57 will be updated following the measurements.
- It should now be possible to operate the motor.
- Low speed and starting of the motor may be further optimised by adjusting P-11.
 - In PM motor control mode, P-11 adjust the additional current injected into the motor at low frequency to help maintain the rotor alignment and ensure reliable starting.
- Speed regulation and response to load changes may be improved by adjusting P-11 Vector Gain to suit the motor and connected load.
 - Higher values will provide a more dynamic behaviour at the risk of instability.

Overload Management (relevant parameters)

Par.	Description	Minimum	Maximum	Default	Units
P-60	Motor Overload Management	-	-	-	-
	Index 1: Thermal Overload Retention	0	1	0	1
	0: Disabled 1: Enabled. When enabled, the drive calculated motor overload protection information is retained after the mains power is removed from the drive.				
	Index 2: Thermal Overload Reaction	0	1	1	1
	0: Trip. When the overload accumulator reaches the limit, the drive will trip on It.trp to prevent damage to the motor. 1: No trip, current limit reduction. When the overload accumulator reaches 90% of, the output current limit is internally reduced to 100% of P-08 in order to avoid an It.trp. The current limit will return to the setting in P-54 when the overload accumulator reaches 10%.				

6.4 P-00 READ ONLY STATUS PARAMETERS

Par.	Description	Explanation
P00-01	Analog Input 1 Value (%)	100% = max input voltage.
P00-02	Analog Input 2 Value (%)	100% = max input voltage.
P00-03	Speed Controller Reference (Hz / RPM)	Displayed in Hz if P-10 = 0, otherwise RPM.
P00-04	Digital Input Status	Drive digital input status.
P00-05	PI Output (%)	Displays value of the User PI output.
P00-06	DC Bus Voltage Ripple (V)	Measured DC bus ripple.
P00-07	Motor Voltage (V)	Value of RMS voltage applied to motor.
P00-08	DC Bus Voltage (V)	Internal DC bus voltage.
P00-09	Heatsink Temperature (°C)	Temperature of heatsink in °C.
P00-10	Run Time Since Date of Manuf. (Hours)	Not affected by resetting factory default parameters.
P00-11	Run Time Since Last Trip (1) (Hours)	Run-time clock stopped by drive disable (or trip), reset on next enable only if a trip occurred. Reset also on next enable after a drive power down.
P00-12	Run Time Since Last Trip (2) (Hours)	Run-time clock stopped by drive disable (or trip), reset on next enable only if a trip occurred (under-volts not considered a trip) – not reset by power down / power up cycling unless a trip occurred prior to power down.
P00-13	Trip Log	Displays most recent 4 trips with time stamp.
P00-14	Run Time Since Last Enable (Hours)	Run-time clock stopped on drive disable, value reset on next enable.
P00-15	Dc Bus Voltage Log (V)	8 most recent values prior to trip, 256ms sample time.
P00-16	Heatsink Temperature Log (°C)	8 most recent values prior to trip, 30s sample time.
P00-17	Motor Current Log (A)	8 most recent values prior to trip, 256ms sample time.
P00-18	DC Bus Voltage Ripple Log (V)	8 most recent values prior to trip, 22ms sample time.
P00-19	Internal Temperature Log (°C)	8 most recent values prior to trip, 30 s sample time.
P00-20	Internal Temperature (°C)	Actual internal ambient temperature in °C.
P00-21	CAN Process Data Input	Incoming process data (RX PDO1) for CAN: PI1, PI2, PI3, PI4.
P00-22	CAN Process Data Output	Outgoing process data (TX PDO1) for CAN: PO1, PO2, PO3, PO4.
P00-23	Accumulated Time with Heatsink > 85°C (Hours)	Total accumulated hours and minutes of operation above heatsink temp of 85°C.
P00-24	Accumulated Time with Internal Temp > 80°C (Hours)	Total accumulated hours and minutes of operation with drive internal ambient above 80°C.
P00-25	Estimated Rotor Speed (Hz)	In vector control modes, estimated rotor speed in Hz.
P00-26	kWh meter / MWh meter	Total number of kWh / MWh consumed by the drive.
P00-27	Cooling Fan Operating Lifetime (Hours)	Time displayed in hh:mm:ss. First value displays time in hrs, press up to display mm:ss.
P00-28	Software Version	Version number and checksum. "1" on LH side indicates I/O processor, "2" indicates power stage.
P00-29	Drive Type	Drive rating, drive type and software version codes.
P00-30	Drive Serial Number	Unique drive serial number.
P00-31	Motor Current Id / Iq	Displays the magnetising current (Id) and torque current (Iq). Press UP to show Iq.
P00-32	Actual Eff. Switching Frequency (kHz)	Actual switching frequency used by drive.
P00-33	O-I Fault Counter	These parameters log the number of times specific faults or errors occur, and are useful for diagnostic purposes.
P00-34	O-Volts Fault Counter	
P00-35	U-Volts Fault Counter	
P00-36	Heatsink O-Temp Counter	
P00-37	B O-I Fault Counter	
P00-38	Internal O-Temp Counter	
P00-39	Modbus RTU Fault Counter	
P00-40	CAN Fault Counter	

P00-41	I/O Comms Fault Counter	
P00-42	DSP Comms Fault Counter	
P00-43	Drive Total Life Time (Hours)	Total lifetime of drive with power applied.
P00-44	Phase U Current Offset & Ref	Internal value.
P00-45	Phase V Current Offset & Ref	Internal value.
P00-46	Phase W Current Offset & Ref	Internal value.
P00-47	Index 1: Fire Mode Total Active Time Index 2: Fire Mode Activation Count	Total activation time of Fire Mode. Displays the number of times Fire Mode has been activated.
P00-48	Scope Channel 1 & 2	Displays signals for scope channels 1 & 2.
P00-49	Scope Channel 3 & 4	Displays signals for scope channels 3 & 4.
P00-50	Bootloader and Motor Control	Internal value.

7. MODBUS RTU COMMUNICATIONS

7.1 INTRODUCTION

The EDrive E3 can be connected to a Modbus RTU network via the RJ45 connector on the front of the drive. See specifications to the right.

7.2 RJ45 CONNECTOR CONFIGURATION

For full MODBUS RTU register map information please refer to your ENERVEL Representative.

Local contacts can be found by visiting our website www.enervel.com

7.3 MODBUS TELEGRAM STRUCTURE

The ENERVEL supports Master / Slave Modbus RTU communications, using the 03 Read Holding Registers and 06 Write Single Holding Register commands. Many Master devices treat the first Register address as Register 0, therefore it may be necessary to convert the Register Numbers detail in section 7.4 by subtracting 1 to obtain the correct Register address. The telegram structure is shown in the table to the right.

Protocol	Modbus RTU
Error Check	CRC
Baud Rate	9600bps, 19200bps, 38400bps, 57600bps, 115200bps (default)
Data format	1 start bit, 8 data bits, 1 stop bits, no parity
Physical signal	RS 485 (2-wire)
User interface	RJ45

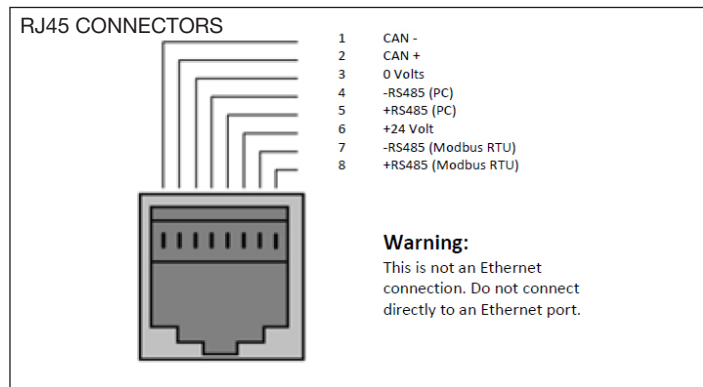

7.4 MODBUS REGISTER MAP

Register Number	Par.	Type	Supported Commands	Function		Range	Explanation
				Low Byte	High Byte		
1	-	R/W	03,06,16	Drive Control Command Modbus Speed reference set point		0..3	16 Bit Word. Bit 0 : Low = Stop, High = Run Enable Bit 1 : Low = Decel Ramp 1 (P-04), High = Decel Ramp 2 (P-24) Bit 2 : Low = No Function, High = Fault Reset Bit 3 : Low – No Function, High = Coast Stop Request
2	-	R/W	03,06,16	Modbus Speed reference set point		0..5000	Set point frequency x10, e.g. 100 = 10.0Hz
4	-	R/W	03,06,16	Acceleration and Deceleration Time			Ramp time in seconds x 100, e.g. 250 = 2.5 seconds
6	-	R	03	Error Codes	Drive Status		Low Byte = Drive Error Code, see section 10.1 High Byte = Drive Status as follows :- 0 : Drive Stopped 1: Drive Running 2: Drive Tripped 7
7	-	R	03	Output Motor Frequency		0..480	Output frequency in Hz x10, e.g. 100 = 10.0Hz
8	-	R	03	Output Motor Current		0..15	Output Motor Current in Amps x10, e.g. 10 = 1.0 Amps
11	-	R	03	Digital input status		0..1000	Indicates the status of the 4 digital inputs Lowest Bit = 1 Input 1
20	P00-01	R	03	Analog Input 1 value		0..1000	Analog input % of full scale x10, e.g. 1000 = 100%
21	P00-02	R	03	Analog Input 2 value		0..1000	Analog input % of full scale x10, e.g. 1000 = 100%
22	P00-03	R	03	Speed Reference Value		0..1000	Displays the setpoint frequency x10, e.g. 100 = 10.0Hz
23	P00-04	R	03	DC bus voltage		0..1000	DC Bus Voltage in Volts
24	P00-05	R	03	Drive temperature		0..100	Drive heatsink temperature in °C

All user configurable parameters are accessible as Holding Registers, and can be Read from or Written to using the appropriate Modbus command. The Register number for each parameter P-04 to P-60 is defined as 128 + Parameter number, e.g. for parameter P-15, the register number is 128 + 15 = 143. Internal scaling is used on some parameters, for further details, please contact your ENERVEL Representative.

8. TROUBLESHOOTING

8.1 FAULT CODE MESSAGES

Fault Code	No.	Description	Suggested Remedy
no-Flt	00	No Fault	None required
01-b	01	Brake channel over current	Check external brake resistor condition and connection wiring
OL-br	02	Brake resistor overload	The drive has tripped to prevent damage to the brake resistor
0-1	03	Output Over Current	Instantaneous Over current on the drive output. Excess load or shock load on the motor.
1_t-trP	04	Motor Thermal Overload (I2t)	The drive has tripped after delivering >100% of value in P-08 for a period of time to prevent damage to the motor.
PS-trP	05	Power stage trip	Check for short circuits on the motor and connection cable
0-volt	06	Over voltage on DC bus	Check the supply voltage is within the allowed tolerance for the drive. If the fault occurs on deceleration or stopping, increase the deceleration time in P-04 or install a suitable brake resistor and activate the dynamic braking function with P-34
U-volt	07	Under voltage on DC bus	The incoming supply voltage is too low. This trip occurs routinely when power is removed from the drive. If it occurs during running, check the incoming power supply voltage and all components in the power feed line to the drive.
0-t	08	Heatsink over temperature	The drive is too hot. Check the ambient temperature around the drive is within the drive specification. Ensure sufficient cooling air is free to circulate around the drive. Increase the panel ventilation if required. Ensure sufficient cooling air can enter the drive, and that the bottom entry and top exit vents are not blocked or obstructed.
U-t	09	Under temperature	Trip occurs when ambient temperature is less than -10°C. Temperature must be raised over -10°C in order to start the drive.
E-triP	10	Factory Default parameters loaded	
P-dEF	11	External trip	E-trip requested on digital input 3. Normally closed contact has opened for some reason. If motor thermistor is connected check if the motor is too hot.
SC-065	12	Optibus comms loss	Check communication link between drive and external devices. Make sure each drive in the network has its unique address.
Flt-dc	13	DC bus ripple too high	Check incoming supply phases are all present and balanced
P-LOSS	14	Input phase loss trip	Check incoming power supply phases are present and balanced.
h 0-1	15	Output Over Current	Check for short circuits on the motor and connection cable
th-Flt	16	Faulty thermistor on heatsink	
dAtA-F	17	Internal memory fault. (IO)	Press the stop key. If the fault persists, consult you supplier.
4-20 F	18	4-20mA Signal Lost	Check the analog input connection(s).
dAtA-E	19	Internal memory fault. (DSP)	Press the stop key. If the fault persists, consult you supplier.
F-Ptc	21	Motor PTC thermistor trip	Connected motor thermistor over temperature, check wiring connections and motor
FAn-F	22	Cooling Fan Fault (IP66 only)	Check / replace the cooling fan
0-hEAt	23	Drive internal temperature too high	Drive ambient temperature too high, check adequate cooling air is provided
OUt-F	26	Output Fault	Indicates a fault on the output of the drive, such as one phase missing, motor phase currents not balanced. Check the motor and connections.
AtF-02	41	Autotune Fault	The motor parameters measured through the autotune are not correct. Check the motor cable and connections for continuity Check all three phases of the motor are present and balanced
SC-F01	50	Modbus comms loss fault	Check the incoming Modbus RTU connection cable Check that at least one register is being polled cyclically within the timeout limit set in P-36 Index 3
SC-F02	51	CAN comms loss trip	Check the incoming CAN connection cable Check that cyclic communications take place within the timeout limit set in P-36 Index 3

NOTES

NOTES

NOTES

ENERVEX Inc.
1685 Bluegrass Lakes
Parkway
Alpharetta, GA 30004
USA

P: 770.587.3238
F: 770.587.4731
T: 800.255.2923
info@enervex.com
www.enervex.com

ENERVEX® 
VENTING DESIGN SOLUTIONS