

ENERVEX BPV 200-700 BOX POWER VENTER

010.1090.0818 01.21

Installation & Operating Manual

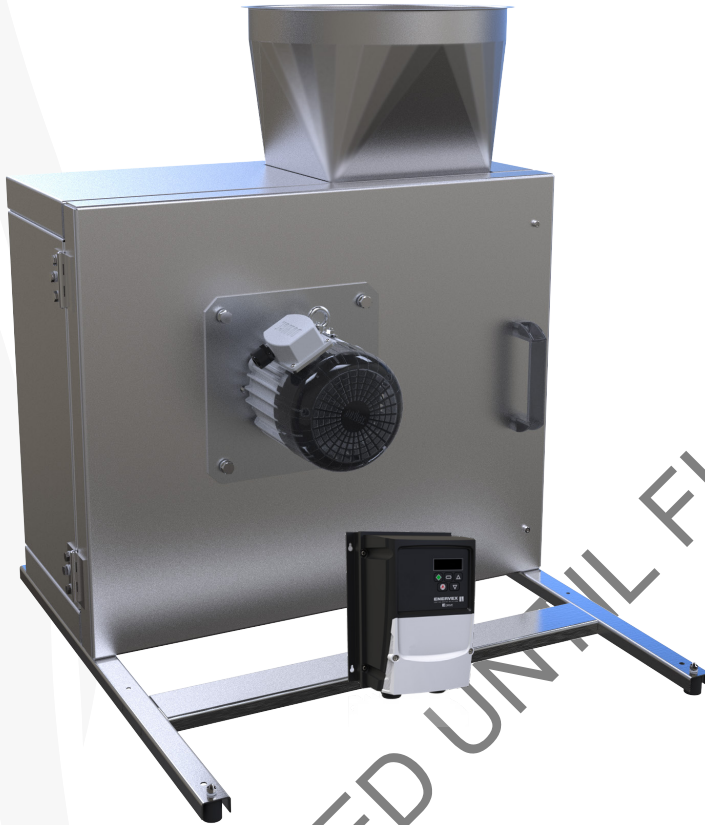

LISTED

UL File E467733

READ AND SAVE THESE INSTRUCTIONS!

ENERVEX Inc.
1685 Bluegrass Lakes
Parkway
Alpharetta, GA 30004
USA

P: 770.587.3238
F: 770.587.4731
T: 800.255.2923
info@enervex.com
www.enervex.com

ENERVEX® 
VENTING DESIGN SOLUTIONS



This symbol shows that ENERVEX BPV Box Power Venters are listed under Category Codes MCQX and ZACT.

Symbol Legend

The following terms are used throughout this manual to bring attention to the presence of potential hazards, or to important information concerning the product.



DANGER: Indicates an imminent hazardous situation which, if not avoided, will result in death, serious injury or substantial property damage.



WARNING: Indicates an imminent hazardous situation which, if not avoided, may result in personal injury or property damage.



DANGER: Indicates an imminent electrical shock hazard which, if not avoided, will result in death, serious injury or substantial property damage.

How to use this manual

This installation manual does not contain any system design documentation. System design documentation is available from any authorized ENERVEX representative. Accessories, Box Power Venters, and variable frequency drives are not covered by this manual. Please refer to these component's individual manuals.

TO REDUCE THE RISK OF FIRE, ELECTRICAL SHOCK OR INJURY TO PERSONS, OBSERVE THE FOLLOWING:

1. Use this unit in the manner intended by the manufacturer. If you have questions, contact the manufacturer at the address or telephone number listed on the front of the manual.
2. Before servicing or cleaning the unit, switch off at service panel and lock service panel to prevent power from being switched on accidentally.
3. Installation work and electrical wiring must be done by a qualified person(s) in accordance with applicable codes and standards.
4. Follow the appliance manufacturer's guidelines and safety standards such as those published by the National Fire Protection Association (NFPA), and the American Society for Heating, Refrigeration and Air Conditioning Engineers (ASHRAE), and the local code authorities.
5. This unit must be grounded.

Content

1. GENERAL INFORMATION

1.1 Introduction	4
1.2 Features	4
1.3 Components	4
1.4 Shipping	5
1.5 Accessories	5
1.6 Listings	5
1.7 Warranty	5

2. SPECIFICATIONS AND DIMENSIONS

2.1 Specifications	6
--------------------------	---

3. MECHANICAL INSTALLATION

3.1 General	7
3.2 Positioning	7
3.3 Drain Installation	7
3.4 Door Clearance	8
3.5 Floor or Roof Mounting	8
3.6 Vertical Installation	9
3.7 Outdoor Termination	9
3.8 Field Junction Box	9

4. ELECTRICAL INSTALLATION

4.1 General	10
4.2 Motor Controller Installation	10
4.3 Mounting of EDrive Motor Controller	11
4.4 Grounding Guidelines	11
4.5 EMC Filter Disconnect	11
4.6 Electrical Connection of Motor and EDrive	12
4.7 Motor Terminals Box Connections	12
4.8 Wiring Diagram - BPV 200-250 / 1x120V	12
4.9 Wiring Diagram - BPV 300-700 / 3x208-480V ..	13
4.10 Checking and Changing Rotation of Impeller ...	14
4.11 Installing a Proven Draft Switch	14
4.12 Installation of Stack Probe for PDS Function ...	14

5. STARTUP AND CONFIGURATION

5.1 General	15
5.2 System Testing	15
5.3 Changing Parameters	16
5.4 Read Only Parameters	16

5.5 Resetting Parameters	16
5.6 Resetting a Fault	16
5.7 LED Display	16
5.8 Start Up Sequence (Auto Tune)	17

6. MAINTENANCE AND TROUBLESHOOTING

6.1 Cleaning Intervals	18
6.2 Cleaning	18
6.3 Service	18
6.4 Replacement Parts Ordering	19

7. WARRANTY TERMS20



WARNING

This product is equipped with an electronically commutated (EC-motor) and can not be connected directly to ac mains. Motor must be connected to approved motor controller to ensure proper function. Failure to use approved motor controller may result in damage to the motor.

AVERTISSEMENT

Ce produit est équipé d'un commutateur électronique (moteur EC) et ne peut pas être connecté directement au secteur. Le moteur doit être connecté au contrôleur de moteur approuvé pour assurer un fonctionnement correct. Ne pas utiliser le contrôleur de moteur approuvé peut endommager le moteur.

1. GENERAL INFORMATION

1.1 Introduction

These instructions provide both general guidelines and special requirements for all parts in the BPV Box Power Venter product line. Before specifying a design or beginning an installation please carefully review these instructions. Contact local building or fire officials about restrictions and installation inspection in your area.

1.2 Features

The BPV Box Power Venter is an efficient, high-temperature draft inducer with backward-curved centrifugal impeller. Typical application is the mechanical venting of gas-fired or oil-fired boilers and water heaters - condensing or non-condensing.

It can be installed horizontally or vertically in a chimney system.

The BPV is equipped with an air cooled, maintenance-free Electronically Commutated (EC) motor with pre-lubricated and sealed ball bearings, and includes a factory-programmed Edrive controller to control the motor operation.

The motor and controller is rated at 92% efficiency and able to operate as low as 50 RPM. The motor has integrated protection against overloading, blocking over and under voltage and over-heating.

The power venter housing and the backward inclined impeller is made of 316L stainless steel. The motor and impeller is a complete assembly (drive unit) that can be removed from the housing without removing the power venter from the stack system. The connections are 1/2" flanged type and fit most commercial pre-fabricated chimney systems. The BPV is typically installed hung from ceiling mounting brackets to support the weight.

The BPV is also used as a component in the CASI Chimney Automation System™.

The BPV model is approved for temperatures up to 1400°F (760°C).



WARNING

The Box Power Venter is not to be used to transport solid particles, nor in areas where there is a risk of explosive gases.

1.3 Components

The BPV Box Power Venter includes the components shown in Fig. 1.

1. Housing
2. Motor
3. U-bands (2)
4. EDrive
5. Drain Kit (not shown)

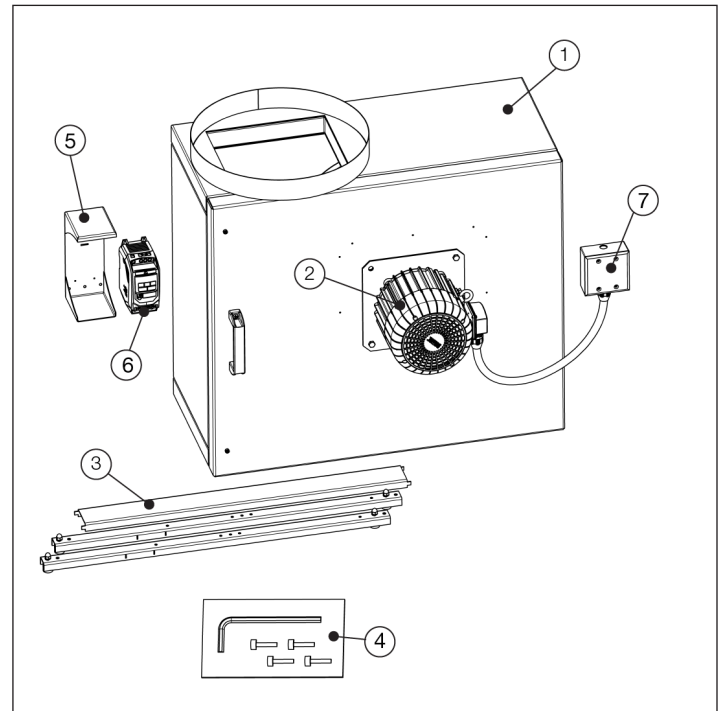

Fig 1

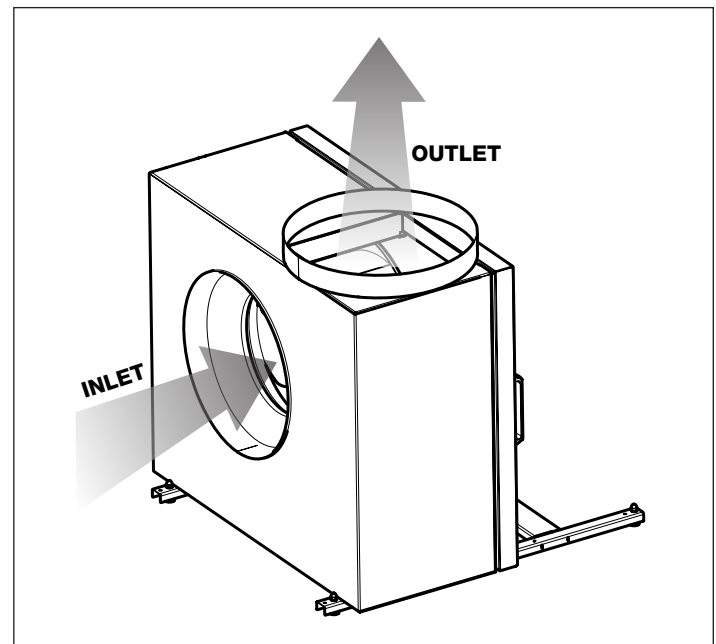

Fig 2

1.4 Shipping

BPV Box Power Venter units are shipped on a pallet and protected by a corrugated box.

Do not place other products or items on top of the box.

After unpacking, the product must be handled in a way to prevent damage to the collars and the power venter housing.

The power venter is shipped with the motor installed on the motor plate/access door and with a dedicated motor controller.

If other components are shipped, they will appear on the shipment packing list.

NOTE: All BPV Power Venters are shipped with a Field Junction Box connected via flexible conduit.

1.5 Accessories (Optional)

- EBC 31 Modulating Pressure Control
- Proven Draft Switch PDS

1.6 Listings

UL Listing under Category MCQX is File No. E467733 and reference to the following standards:

UL 378 Standard For Draft Equipment Edition 4 - Revision Date 2013/09/17

ULC/ORD-C378-75 Guide For The Investigation Of Draft Equipment

ULC/ORD 2162 Commercial Wood-Fired Baking Ovens – Refractory Type Edition 1 - Issue Date 2013/06/01

UL705, Standard for Power Ventilators with special consideration for venting lint-laden air from single or multiple dryers and CSA 22.2 No. 113, Standard for Fans and Ventilators.

CSA C22.2 NO. 113-12 Fans and Ventilators Edition 9 - Revision Date 2012/10/01

1.7 Warranty

2-year factory warranty (see back cover). Complete warranty conditions are available from ENERVEX Inc.

**WARNING**

This duct fan shall be installed a minimum of one meter from any accessible opening of the duct.

AVERTISSEMENT

Ce ventilateur de conduit doit être installé au moins un mètre d'une ouverture accessible du conduit.

2. SPECIFICATIONS AND DIMENSIONS

2.1 Specifications

NOTE: All published voltages relate to power supplied to the EDrive and NOT the motor.

Model		BPV 200	BPV 250	BPV 300	BPV 350	BPV 400	BPV 500	BPV 600	BPV 700
Fan Type		Centrifugal Impeller (B-Wheel)							
Motor Type		ECM, Permanent Magnet							
Voltage to EDrive	VAC	1x120			3x208-240 / 3x400-480				3x400-480
Max. Amperage - EDrive	A	2.3	2.3	7.0 / 4.1	7.0 / 4.1	10.5 / 5.8	10.5 / 5.8	18.0 / 9.5	18.0
Motor Output	HP	0.5	0.5	2	2	3	3	5	10
	kW	0.38	0.38	1.5	1.5	2.2	2.6	3.7	7.5
RPM (Max)		1740	1740	2300	2300	2300	1740	1740	1450
Weight (estimated)	lbs / kg	127 / 57	143 / 65	166 / 76	195 / 88	217 / 99	295 / 134	403 / 183	416 / 189
Nominal Duct Size	in / mm	8 / 200	10 / 250	12 / 300	16 / 400	16 / 400	20 / 500	24 / 600	28 / 700
Dimensions	A in / mm	20.0 / 502	24.0 / 610	27.2 / 690	30.3 / 770	30.3 / 770	36.3 / 921	38.5 / 978	41.0 / 1041
	B in / mm	17.0 / 432	21.0 / 537	23.6 / 600	25.8 / 655	25.8 / 655	31.6 / 803	34.0 / 864	36.5 / 927
	C in / mm	9.5 / 241	11.4 / 290	13.5 / 343	14.1 / 358	15.1 / 384	17.2 / 437	20.1 / 513	22.8 / 579
	D in / mm	3.5 / 89	3.5 / 89	4.0 / 102	4.0 / 102	4.0 / 102	4.0 / 102	4.0 / 102	4.0 / 102
	E in / mm	7.9 / 201	9.8 / 250	11.8 / 300	15.8 / 400	15.8 / 400	19.7 / 500	23.6 / 600	27.6 / 700
	F in / mm	7.9 / 201	9.8 / 250	11.8 / 300	15.8 / 400	15.8 / 400	19.7 / 500	23.6 / 600	27.6 / 700
	G in / mm	18.5 / 470	24.0 / 610	24.0 / 610	32.3 / 820	32.3 / 820	38.8 / 985	38.8 / 985	42.0 / 1067
	H in / mm	9.8 / 248	11.6 / 295	13.8 / 350	14.8 / 375	15.0 / 382	17.6 / 448	18.8 / 470	20.5 / 521
	J in / mm	11.9 / 302	13.6 / 345	14.7 / 373	17.7 / 450	17.7 / 450	20.7 / 527	23.0 / 585	26.0 / 661
	M in / mm	7.9 / 201	10.2 / 258	10.2 / 258	10.2 / 258	10.2 / 258	10.2 / 258	10.2 / 258	10.2 / 258
N in / mm	2.0 / 51	2.0 / 51	2.0 / 51	2.0 / 51	2.0 / 51	2.0 / 51	2.0 / 51	2.0 / 51	

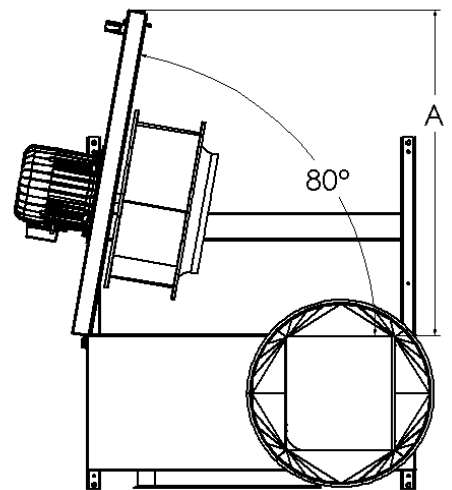
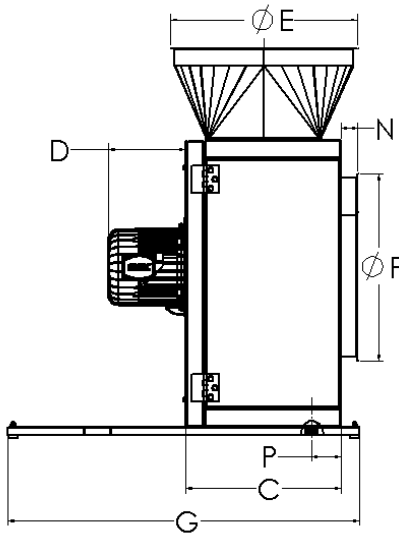
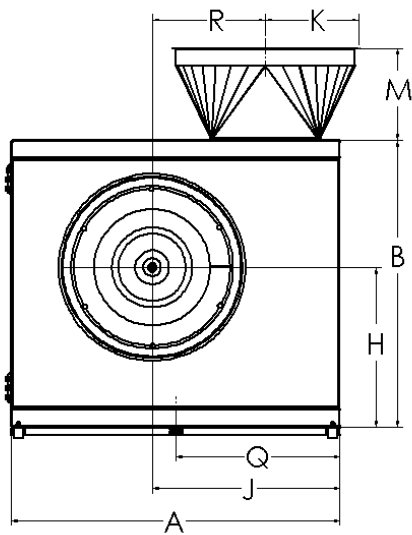

3. MECHANICAL INSTALLATION

3.1 General

The BPV must be installed by a qualified installer in accordance with these instructions and all local codes, or in their absence, with the latest edition of The National Fuel Gas Code (NFPA54/ANSI223.1), NFPA 211, NFPA 31 or Canada CAN/CSA-B149.1-05 National Gas and Propane Installation Code when applicable. The BPV must be mounted so the clearance to combustibles is at min. 18 inches.

Preferably, the BPV should be installed as close to the termination as possible as this offers more flexibility in the selection of chimney type. It can also be installed near the outlet of a heating appliance or in the breeching itself. In addition, it can be used for sidewall vented applications where it discharges through a wall. A drain is provided with the BPV to be installed by the user.

The BPV is for indoor and outdoor installation. Unless installed adjacent to the wall it is discharging through, the chimney material used on the discharge side must be airtight/pressure rated. The chimney must be installed and supported according to the chimney manufacturer's instructions and/or in accordance with NFPA54, NFPA211 and Canada CAN/CSA-B149.1-05. The BPV collars fit most commonly available vents and stacks.

3.2 Positioning

The power venter can be oriented in multiple positions. Acceptable orientations are shown in Fig 3.

The BPV shall never be installed with the motor pointing downwards.

NOTE: If the BPV is mounted in position B or C, a drain may be installed as described in Section 3.3.

3.3 Drain Installation

Install the provided drain if the BPV is mounted horizontally. The drain should be installed near the inlet of the power venter and oriented so it points toward the ground.

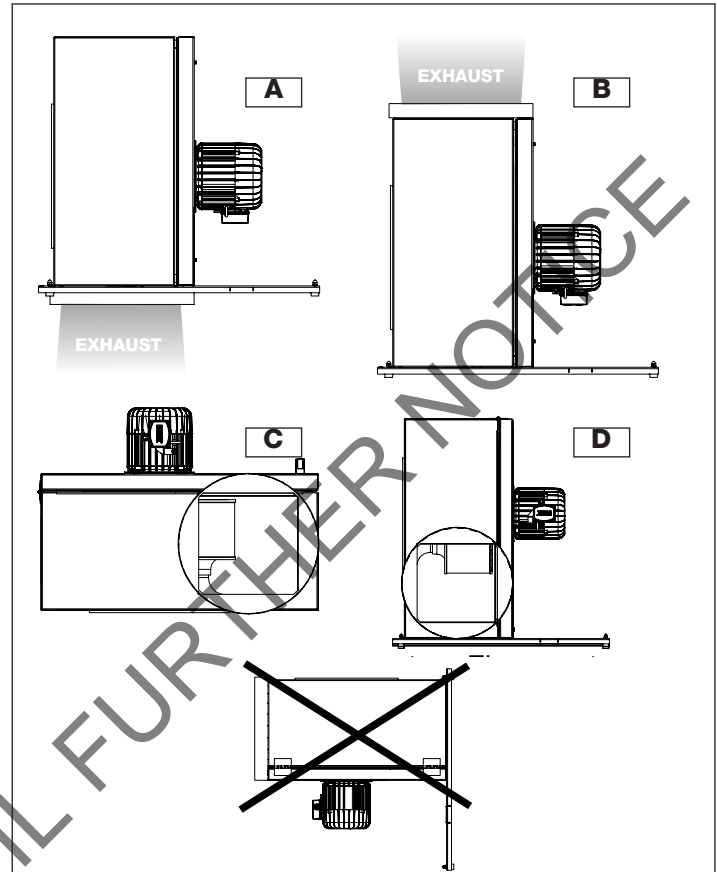

Fig 3



WARNING

The ventilator motor should never hang downward. This can cause condensation build-up around the shaft, and can shorten the product life.

WARNING

Le moteur du ventilateur ne doit jamais pendre vers le bas. Cela peut provoquer une accumulation de condensation autour de l'arbre et réduire la durée de vie du produit.

3.4 Door Clearance

Wherever the power venter is installed, make sure there is enough clearance to open the access door to an angle of approximately 80°, as shown in Fig 4, and to access the locking screws.

	CAUTION
	Never operate the ventilator with open access door
	MISE EN GARDE
	Ne jamais utiliser le ventilateur avec la porte d'accès ouverte.

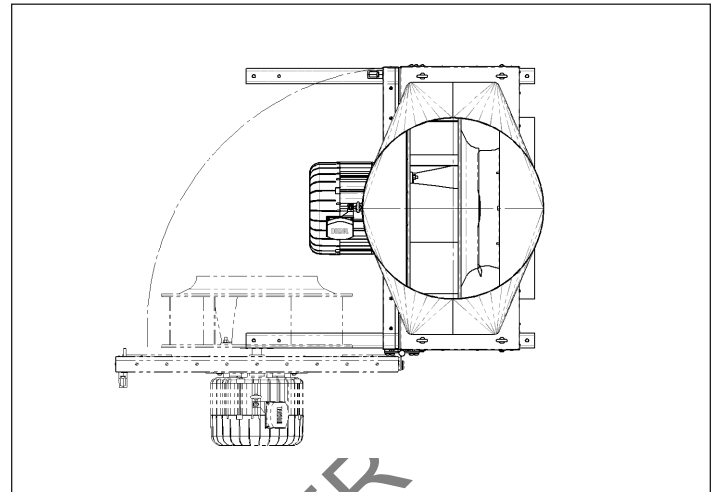

Fig 4

3.5 Floor Or Roof Mounting

The inlet is placed on the backside of the power venter while the outlet is on top. See Fig 5

To minimize transfer of noise and vibration, the power venter should be mounted on a level, stable and vibration-free surface. If mounting on a wooden surface, a cement tile should be placed on the floor prior to mounting as shown in Fig 6.

Once the installation location is selected the support legs must be installed. To facilitate support leg installation, keep ventilator unit on pallet.

For the standard position (Fig 6), bolt holes are pre-drilled and support legs should be aligned and secured with the enclosed hardware.

For all other positions, the legs should be placed in proper position using variable mounting points.

DO NOT FASTEN THE VENTILATOR TO THE BASE.

The ventilator is fitted with sound dampers suited to the requirements of the operating area. Follow the recommendations by the vent or stack manufacturer.

All BPVs have 1/2" flanged connections.

Transitions to most chimney system types are available (not included).

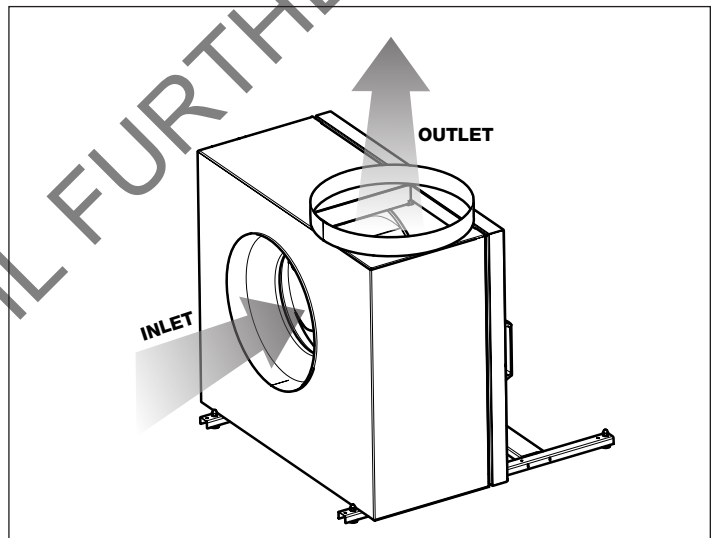

Fig 5

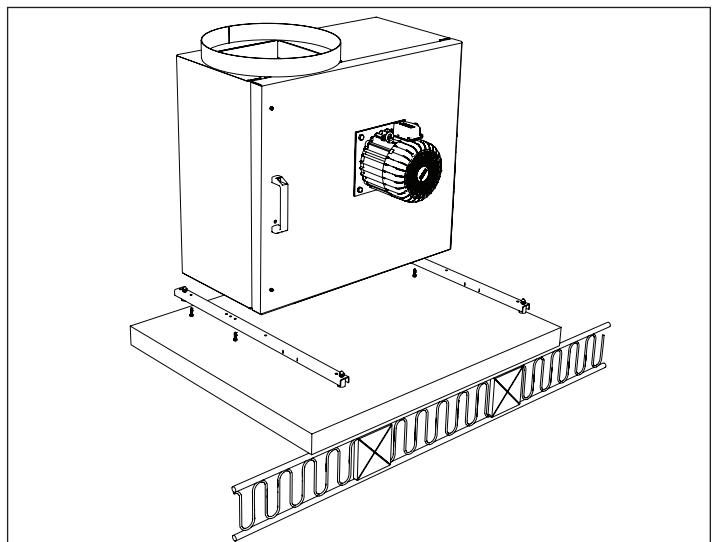

Fig 6

3.6 VERTICAL INSTALLATION

To mount the BPV vertically, suspend the power venter with steel hangers. Once the position of the power venter and hangers is finalized, attach 2 hangers through the mounting holes of the power venter as shown in Fig. 7. Once the power venter is leveled, secure the hangers. Install additional bracing if necessary.

Ceiling bolts must be properly sized to safely carry weight of the power venter unit.

3.7 OUTDOOR TERMINATION

The power venter is suitable for outdoor installations. It can mount directly to the roof or on a roof curb.

3.8 FIELD JUNCTION BOX

The BPV includes a field junction box that is attached to the motor via a flexible conduit. See Fig 8

After mounting the BPV in its proper location and orientation, the Field Junction Box **MUST** be permanently attached to the power venter housing with the supplied sheet metal screws. Orient the the Field Junction Box in a manner that will minimize water ingress.

FAILURE TO FOLLOW THIS PROCEDURE VOIDS THE UL LISTING AND CAN DAMAGE THE MOTOR.

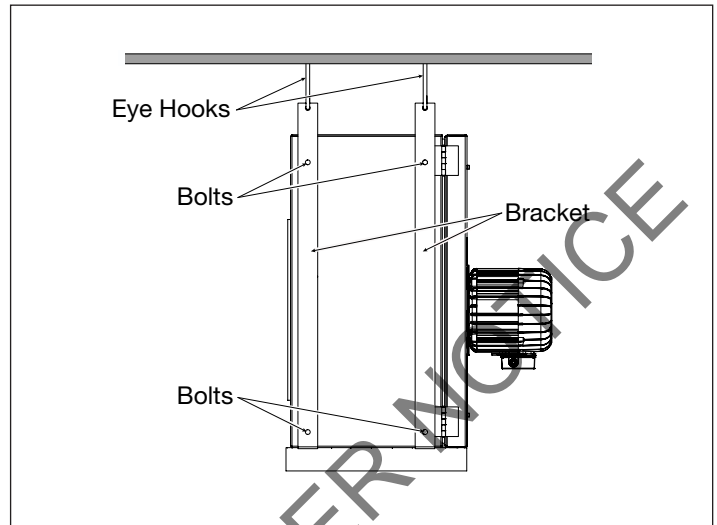

Fig 7

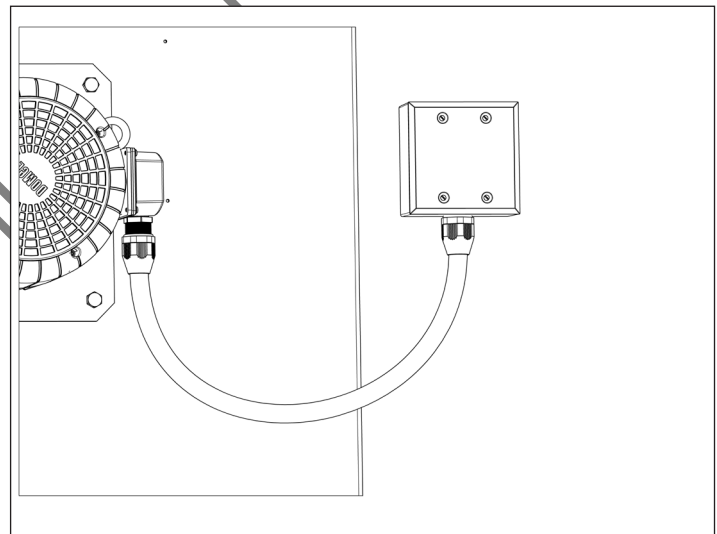

Fig 8

4. ELECTRICAL INSTALLATION

4.1 General

All wiring must be in compliance with the local codes or in their absence, with the National Electric Code, NFPA70. All wiring should be appropriate Class 1 wiring as follows: installed in rigid metal conduit, intermediate metal conduit, rigid non-metallic conduit, electrical metallic tubing, or be otherwise suitably protected from physical damage. All BPV units are equipped with an EC-motor and operate at different voltages so it's important to pay attention to the wiring details.



WARNING

This product is equipped with an electronically commutated (EC-motor) and can not be connected directly to ac mains. Motor must be connected to approved motor controller to ensure proper function. Failure to use approved motor controller may result in damage to the motor.

AVERTISSEMENT

Ce produit est équipé d'un commutateur électronique (moteur EC) et ne peut pas être connecté directement au secteur. Le moteur doit être connecté au contrôleur de moteur approuvé pour assurer un fonctionnement correct. Ne pas utiliser le contrôleur de moteur approuvé peut endommager le moteur.

Note: If any of the original wire supplied with the system must be replaced, use similar wire of the same temperature rating. Otherwise, insulation may melt or degrade, exposing bare wire.



WARNING

All BPV models must be operated with the approved factory-programmed motor drive.
DO NOT CONNECT DIRECTLY TO LINE VOLTAGE!

AVERTISSEMENT

Tous les modèles BPV doivent être utilisés avec l'entraînement motorisé approuvé en usine.
NE PAS CONNECTER DIRECTEMENT À LA TENSION DE LIGNE!



DANGER

Turn off electrical power before servicing. Contact with live electric components can cause shock or death.

Éteignez l'alimentation électrique avant de procéder à l'entretien. Le contact avec des composants électriques sous tension peut provoquer un choc ou la mort.

4.2 Motor Controller

All ENERVEX BPV Box Power Venters come with, and must use, a factory programmed EDrive motor controller with an enclosure rated to NEMA 4X/IP66 for indoor and outdoor installation.

The EDrive E3 motor controller must be mounted within 300 feet of the BPV Box Power Venter. This distance can be increased up to 600 feet with the addition of a line filter (Contact ENERVEX for details).

A motor disconnect switch must be installed between the motor controller and the BPV Box Power Venter, either within sight of the BPV Box Power Venter, or within 50 feet of the BPV Box Power Venter.

Do not activate the motor service disconnect switch while the BPV motor is running - damage could occur to the motor controller.

For more information about the EDrive E3, please refer to the Installation & Operating Manual.

ABOUT SHAFT GROUNDING

Bearing currents are very common problem of Variable Frequency Drives (VFD/Motor Controller) and electronic commutated motors. The electric-discharge machining (EDM) bearing currents are generated in motors because of unbalanced modulated voltage from drive to the motor. Because of stray capacitances in motor, bearing currents are generated in rotor and there is usually no other way to discharge except through bearings. This drastically lowers the life time of the bearings.

The BPV's EC-motor integrates an insulated rotor system, which means that electrical insulation is inserted between rotor and motor shaft. This system provide up to 80% lower shaft voltages and very low bearing current values which eliminates bearing damage.



DANGER

The motor speed drive is suitable for use in a circuit capable of receiving not more than 100 KA RMS symmetrical Amperes at the maximum reated voltage.

Le variateur de vitesse peut être utilisé dans un circuit capable de recevoir des ampères symétriques de plus de 100 KA à la tension maximale.

4.3 Mounting of EDrive Motor Controller

Mount the EDrive motor controller in a location that is only accessible to qualified personal.

The EDrive must be installed within 300 ft of the BPV Box Power Venter..

See Fig 9. For more information about the EDrive E3 please refer the Installation & Operating Manual.

4.4 Grounding Guidelines

The ground terminal of each EDrive E3 should be individually connected DIRECTLY to the source breaker panel ground bus bar (through the filter if installed). EDrive E3 ground connections should not loop from one drive to another, or to, or from any other equipment. Ground loop impedance must confirm to local industrial safety regulations. To meet UL regulations, UL approved ring crimp terminals should be used for all ground wiring connections.

The drive Safety Ground must be connected to system ground. Ground impedance must conform to the requirements of national and local industrial safety regulations and/or electrical codes. The integrity of all ground connections should be checked periodically.

Protective Earth Conductor

The Cross sectional area of the ground conductor must be at least equal to that of the incoming supply conductor.

Safety Ground

This is the safety ground for the drive that is required by code. One of these points must be connected to adjacent building steel (girder, joist), a floor ground rod, or bus bar. Grounding points must comply with local codes.

Motor Ground

The motor ground must be connected to one of the ground terminals on the drive.

Ground Fault Monitoring

As with all inverters, a leakage current to earth can exist. The EDrive E3 is designed to produce the minimum possible leakage current whilst complying with worldwide standards. The level of current is affected by motor cable length and type, the effective switching frequency, the earth connections used and the type of RFI filter installed. If an ELCB (Earth Leakage Circuit Breaker) is to be used, the following conditions apply:

- A Type B Device must be used.
- The device must be suitable for protecting equipment with a DC component in the leakage current.
- Individual ELCBs should be used for each EDrive E3.

4.5 EMC Filter Disconnect

Drives with an EMC filter have an inherently higher leakage current to Ground (Earth). For applications where tripping occurs the EMC filter can be disconnected (on IP20 units only) by completely removing the EMC screw on the side of the product.

Remove the screw as indicated in Fig 10.

The EDrive product range has input supply voltage surge

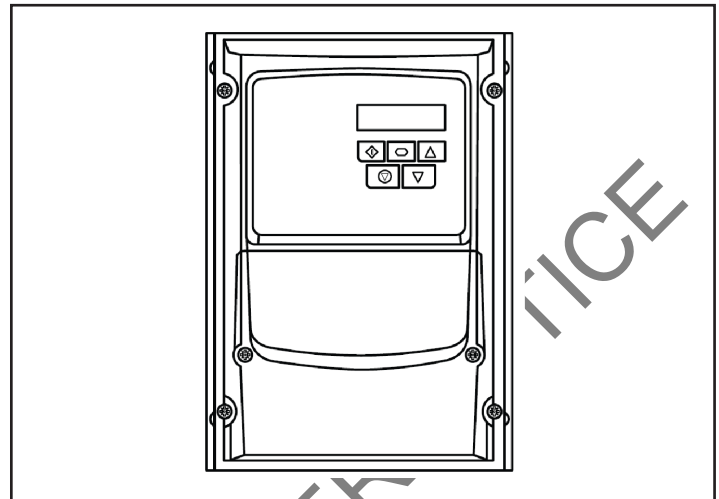

Fig 9



WARNING

For installation in the United States, branch circuit protection must be provided in accordance with the National Electrical Code (NEC).



CAUTION

For installation in Canada, branch circuit protection must be provided in accordance with the Canadian Electrical code

Pour l'installation au Canada, la protection de circuit de branche doit être fournie conformément au Le code canadien de l'électricité.



DANGER

Only qualified electrical personnel familiar with the construction and operation of this equipment and the hazards involved should install, adjust, operate, or service this equipment. Read and understand this manual and other applicable manuals in their entirety before proceeding. Failure to observe this precaution could result in severe bodily injury or loss of life.

Seul un personnel qualifié en électricité, familiarisé avec la construction et le fonctionnement de cet équipement et les risques encourus, doit installer, ajuster, utiliser ou entretenir cet équipement. Lire et comprendre ce manuel et les autres manuels applicables dans leur intégralité avant de continuer. Le non-respect de cette précaution peut entraîner des blessures graves ou la mort.

suppression components fitted to protect the drive from line voltage transients, typically originating from lightning strikes or switching of high power equipment on the same supply.

When carrying out a HiPot (Flash) test on an installation in which the drive is built, the voltage surge suppression components may cause the test to fail. To accommodate this type of system HiPot test, the voltage surge suppression components can be disconnected by removing the VAR screw. After completing the HiPot test, the screw should be replaced and the HiPot test repeated. The test should then fail, indicating that the voltage surge suppression components are once again in circuit.

4.6 Electrical Connection of the Motor and EDrive

The motor should be connected to the EDrive E3 U, V, and W terminals using a suitable 3 or 4 core cable. Where a 3 core cable is utilised, with the shield operating as an earth conductor, the shield must have a cross sectional area at least equal to the phase conductors when they are made from the same material. Where a 4 core cable is utilised, the earth conductor must be of at least equal cross sectional area and manufactured from the same material as the phase conductors.

The motor earth must be connected to one of the EDrive E3 earth terminals.

Maximum permitted motor cable length for all models: 100 meters shielded, 150 meters unshielded.

Where multiple motors are connected to a single drive using parallel cables, an output choke must be installed..

The BPV sizes 200-250 require four (4) 14AWG conductors between the EDrive and the motor. (Three (3) Power lines, and one (1) dedicated Ground wire.)

The BPV Sizes 300-700 require four (4) 12AWG conductors between the EDrive and the motor. (Three (3) Power lines, and one (1) dedicated Ground wire.)

Make all necessary connections to the power and low-voltage terminals (see 4.8-4.9 Wiring Diagram).

4.7 Motor Terminal Box Connections

Do not install any mechanical or electro-mechanical switching devices between the drive and motor. Where a local isolator is installed close to the motor, this should be interlocked with the drive control circuit to ensure the drive is disabled when the motor is isolated.

Most general purpose motors are wound for operation on dual voltage supplies. This is indicated on the nameplate of the motor. This correct voltage setting must be selected when installing the motor by selecting either STAR or DELTA connection. STAR always gives the higher of the two voltage ratings.

4.8 WIRING DIAGRAM - BPV200-250 / 1X120V

NOTE: All published voltages relate to power supplied to the EDrive and NOT the motor.

BPV 200-250 Box Power Venters operate at 1x120 VAC.

The wiring diagram in Fig. 11 is a typical wiring diagram for a BPV 200-250 with 120V supply voltage to the motor drive.

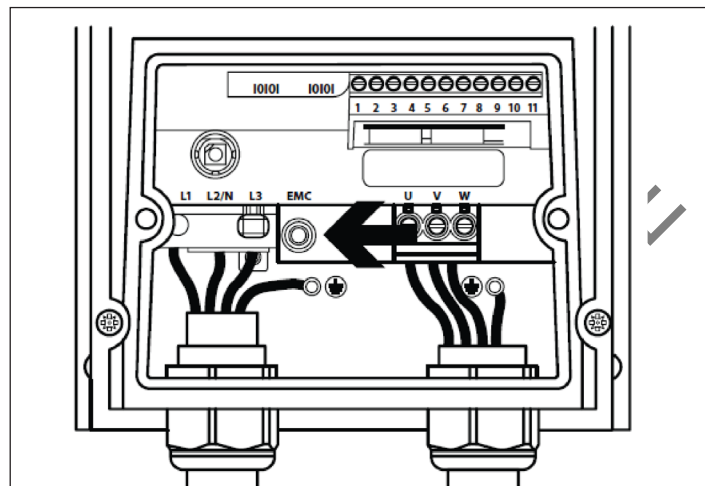

Fig 10



DANGER

This EDrive contains high voltage capacitors that take time to discharge after removal of the main supply. Before working on the drive, ensure isolation of the main supply from line inputs. Wait ten (10) minutes for the capacitors to discharge to safe voltage levels. Failure to observe this precaution could result in severe bodily injury or loss of life.

Cette EDrive contient des condensateurs à haute tension qui mettent du temps à se décharger après le retrait de l'alimentation principale. Avant de travailler sur le variateur, veuillez à isoler l'alimentation principale des entrées de ligne. Attendez dix (10) minutes que les condensateurs se déchargent à des niveaux de tension sûrs. Le non-respect de cette précaution peut entraîner des blessures graves ou la mort.

The BPV is listed with an EDrive motor controller which is shipped with the power venter. The wiring diagram reflects the use of this controller.

4.9 Wiring Diagram - BPV 300-700 / 3X208-480V

NOTE: All published voltages relate to power supplied to the EDrive and NOT the motor.

The BPV 300-600 Box Power Venters operate at 3x208-240 VAC or 3 x 400-480 VAC. The BPV 700 can only operate at 3x400-480 VAC.

The BPVs are listed with an EDrive motor controller which is shipped with the power venter. The wiring diagram in Fig. 11 reflects the use of this controller.



DANGER

Only qualified electrical personnel familiar with the construction and operation of this equipment and the hazards involved should install, adjust, operate, or service this equipment. Read and understand this manual and other applicable manuals in their entirety before proceeding. Failure to observe this precaution could result in severe bodily injury or loss of life.

Seul un personnel qualifié en électricité, familiarisé avec la construction et le fonctionnement de cet équipement et les risques encourus, doit installer, ajuster, utiliser ou entretenir cet équipement. Lire et comprendre ce manuel et les autres manuels applicables dans leur intégralité avant de continuer. Le non-respect de cette précaution peut entraîner des blessures graves ou la mort.

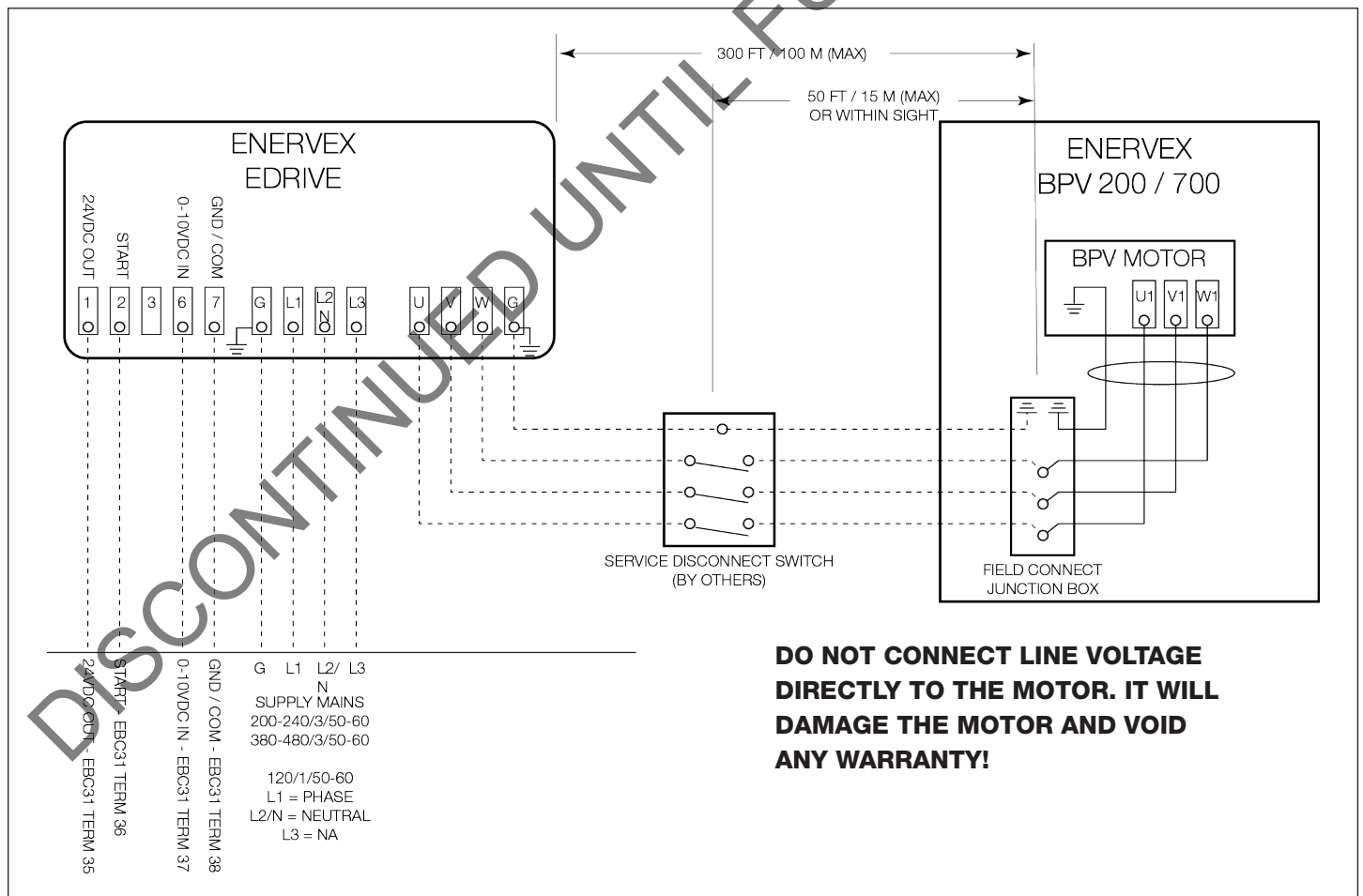

DO NOT CONNECT LINE VOLTAGE DIRECTLY TO THE MOTOR. IT WILL DAMAGE THE MOTOR AND VOID ANY WARRANTY!

Fig 11

4.10 Checking And Changing Rotation Of Impeller

To check the rotation of the impeller, visually check the motor rotation and make sure it matches the rotation arrow. See Fig. 12.

It is possible for the BPV to operate with improper rotation. However, the power venter will only provide 25–30% of full capacity, will cause damage to components and should be avoided.

Fan rotation can be changed on the EDrive by switching the attachment position of any two power leads.

4.11 Installing A Proven Flow System

If required by local codes, a safety system can be interlocked with the appliance(s) to prove power venter operation. The safety system could utilize a Proven Draft Switch (PDS), a thermal switch, a flow switch or a sail switch. The device must be interlocked with the appliance(s) so it shuts down in case of power venter failure or power failure.

Please refer to the PDS Installation Manual for wiring instructions.

If the installation includes an EBC 30/31 Modulating Pressure Fan Control, a PDS is not required as the function is integrated into the control.

4.12 Installation Of Stack Probe For PDS Function

Install the probe for the Proven Draft Switch (PDS) in a vent connector, at the end of the common manifold or at another point where. The probe must be located between the appliance and the power venter.

Preferably, the probe should be located so dimension "A" is at least 3 vent diameters from a change of direction, a draft hood, a draft diverter, or a barometric damper. If layout does not allow proper location, it may have an impact on performance. See Fig 13.

The tip of the probe MUST be flush with the inner chimney wall to get a proper pressure reading.

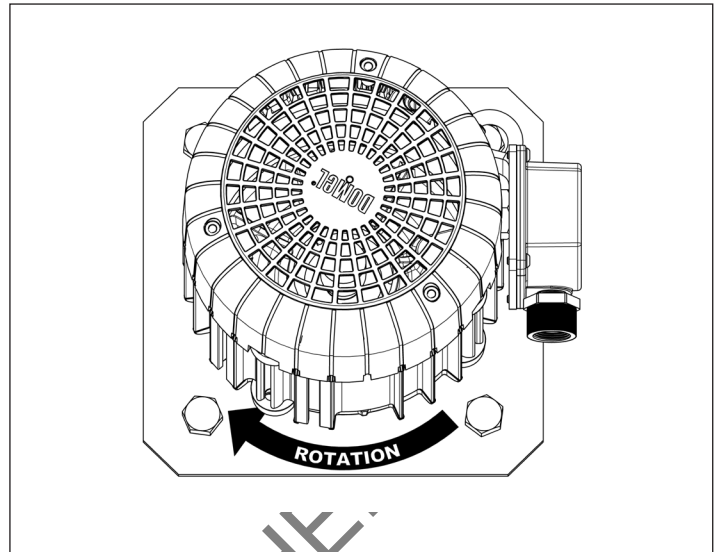



Fig 12

WARNING



Correct direction of wheel rotation is critical. Reversed rotation will result in poor air performance, motor overloading and possible burnout.

AVERTISSEMENT



La turbine doit impérativement tourner dans le bon sens. Une rotation en sens inverse entraînerait de mauvaises performances de soufflage, une surcharge du moteur voire un grillage du moteur.

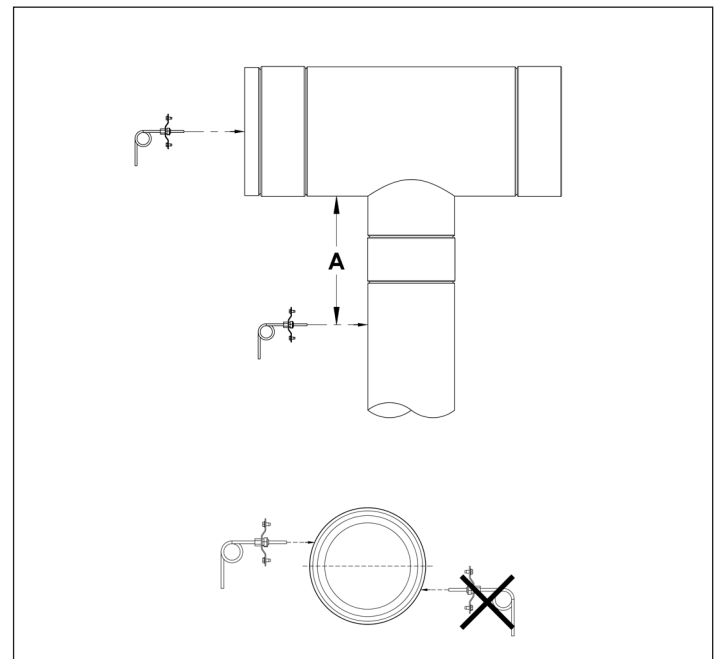







Fig 13

5. STARTUP AND CONFIGURATION

5.1 Managing The Keypad

The EDrive is configured and its operation monitored via the keypad and display.

	NAVIGATE	Used to display real-time information, to access and exit parameter edit mode and to store parameter changes	
	UP	Used to increase speed in real-time mode or to increase parameter values in parameter edit mode	
	DOWN	Used to decrease speed in real-time mode or to decrease parameter values in parameter edit mode	
	RESET / STOP	Used to reset a tripped drive. When in Keypad mode is used to Stop a running drive.	
	START	When in keypad mode, used to Start a stopped drive or to reverse the direction of rotation if bidirectional keypad mode is enabled	

5.2 Operating the Display

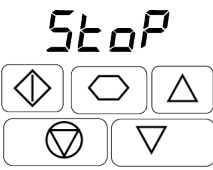
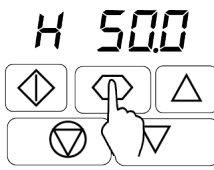
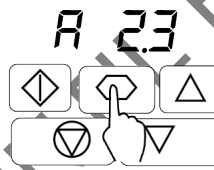
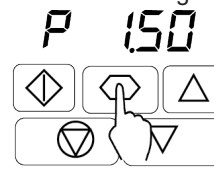
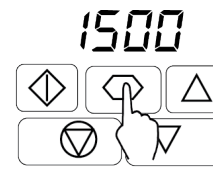
				
Drive Stopped / Disabled	Drive is enabled / running, display shows the output frequency (Hz)	Press the Navigate key for < 1 second. The display will show the motor current (Amps)	Press the Navigate key for < 1 second. The display will show the motor Power (kW)	If P-10 > 0, pressing the Navigation key for < 1 second will display the motor speed (RPM)

5.3 Changing Parameters

	Press and hold the Navigate button >2 seconds
	Use the UP and DOWN buttons to selected the required parameter
	Press the Navigate button for <1 second
	Adjust the value using the UP and DOWN buttons
	Press for <1 second to return to the parameter menu
	Press for >2 seconds to return to the operating display

5.4 Read Only Parameter Access

	Press and hold the Navigate button >2 seconds
	Use the UP and DOWN buttons to selected the required parameter
	Press the Navigate button for <1 second
	Adjust the value using the UP and DOWN buttons
	Press for <1 second to return to the parameter menu
	Press for >2 seconds to return to the operating display

5.5 Resetting Parameter

	To reset parameter values to their factory default settings, press and hold UP, DOWN and STOP buttons for >2 seconds. The display will show "P-def"
	Press the STOP buttons This will display "STOP"

5.6 Resetting A Fault

	Press the STOP button. The display will show "StoP".

5.7 LED Display

The EDrive E3 has a built in 6-digit 7-Segment LED display. In order to display certain warning, the following methods are used.

5.7.1 LED Display Layout

See Fig 14

5.7.2 LED Display Meaning

See table below

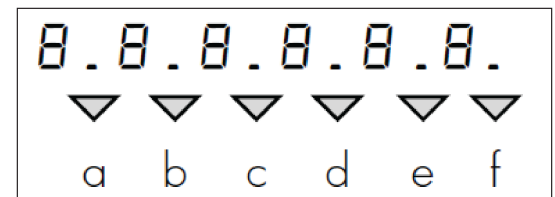

Fig 14

LED Segments	Behaviour	Meaning
a, b, c, d, e, f	Flashing all together	Overload, motor output current exceeds P-08
a and f	Flashing alternately	Mains Loss (Incoming AC power has been removed)
a	Flashing	Fire Mode Active









5.8 Start up Sequence (Auto Tune)

This start up process covers a BPV Box Power Venter with EDrive E3 controlled by an EBC 24 or EBS 31 Modulating Draft Controller, which is the most common configuration for a BPV Box Power Venter. Start up processes for other configurations are available from ENERVEX.

Note, that one of the most important steps in the start up process is to activate “Auto Tune”. Any time a parameter change is taking place, the last part is always to activate “Auto Tune”.

These are the steps needed to perform a successful Auto Tune & start up.

Start Signal: From EBC to Terminal 1 (eDrive).
From EBC to Terminal 2 (eDrive).
Speed Ref: From EBC to Terminal 6 (eDrive).
From EBC to Terminal 7 (eDrive).

1. Remove the control wire from EDrive Terminal 1.
2. Press and hold the  button on the eDrive for 5+ seconds. This will take you to the parameter list (likely P01).
3. Scroll to P14 & Set P14 to “1685” (with the   keys), press the  button to accept.
4. Scroll to P38, Set P38 to “0” (with the keys), press the  button to accept.
5. Scroll to P52 and set P52 to “1” then press and hold the  button until the display indicates the drive is in “Auto Tune”, then let go of the  button.
After Auto Tune is complete, the eDrive should display “STOP”.
6. Program the EBC Controller, if needed.
7. Re-connect the control wire to EDrive Terminal 1. The EDrive should display H xxx (Hertz to the motor).
8. Confirm that the motor rotation direction is correct.
9. Press & Release the  button on the EDrive until “Amps” is displayed, note the Amp draw. Note the Amp screen is designated by Axxx.
10. When done: If it is desired to lock the parameters: return P38 to “0” then return P14 to “1700”.

6. MAINTENANCE AND TROUBLESHOOTING

6.1 Cleaning Intervals

The BPV Box Power Venter is designed for prolonged use. It must be inspected and cleaned at least every 12 months. The need for cleaning is dependent on application type and power venter operation. In oil fired applications, periodic cleaning is required and during the first couple months the power venter should be inspected every month to determine soot build up rate. If soot accumulates, it must be removed to prevent a fire and to ensure efficient operation of the heating appliance(s).

	DANGER
Always disconnect, lock and tag power source before installing or servicing. Failure to disconnect power source can result in fire, shock or serious injury.	

	DANGER
Pour écarter les risques d'incendie, de choc électrique ou de blessure grave, veiller à toujours débrancher, verrouiller et étiqueter la source de courant avant l'installation ou l'entretien	

6.2 Cleaning

Deposits should be removed from the impellers and the bottom of the BPV:

1. Turn power venter off at the service disconnect switch.
2. When Box Power Venter wheel no longer rotates, remove the bolts holding the motor drive unit in place and lift out the whole drive assembly. See Fig. 15.
3. Clean inside housing and wheel with suitable water detergent solution.
4. Dry all parts thoroughly with cloth.
5. Place the drive unit in its original position and secure the bolts.
6. Turn power venter on.

Vibrations can be caused by a dirty impeller. If necessary, the impeller wheel can be removed. Prior to removal, mark the impeller position on the shaft. Do not remove balancing weight(s) on the impellers. No other maintenance is required.

6.3 Service

Available spare parts are shown in Section 6.4 Replacement Parts Ordering.

The motor has sealed and permanently lubricated bearings. Bearing replacement should only be done by ENERVEX or an authorized motor repair shop.

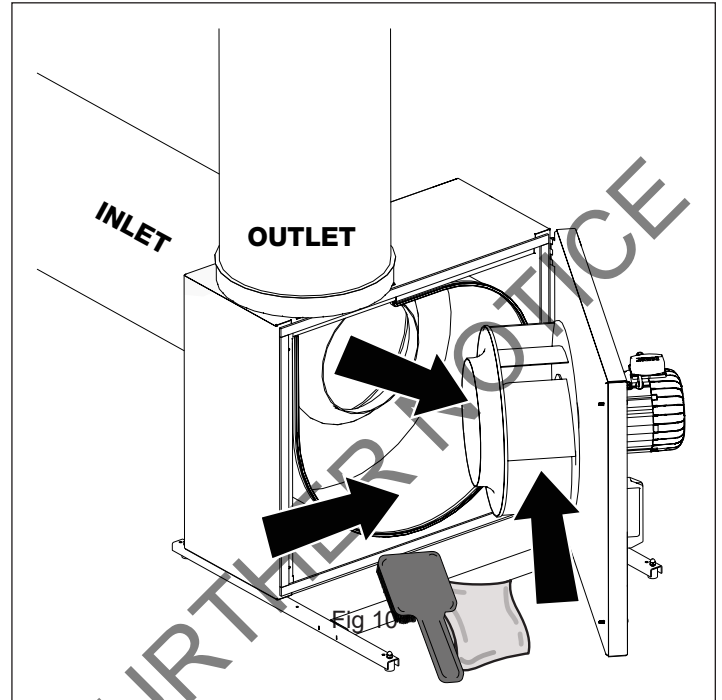



Fig 15

	WARNING
This unit should be made non-functional when cleaning the wheel or housing (fuses removed, disconnect locked off).	

	AVERTISSEMENT
L'appareil doit être rendu non opérationnel lors du nettoyage de la turbine ou du caisson (fusibles, retirés, sectionneur verrouillé).	

6.4 Replacement Parts Ordering

When ordering replacement parts, please have model number and part position number available.

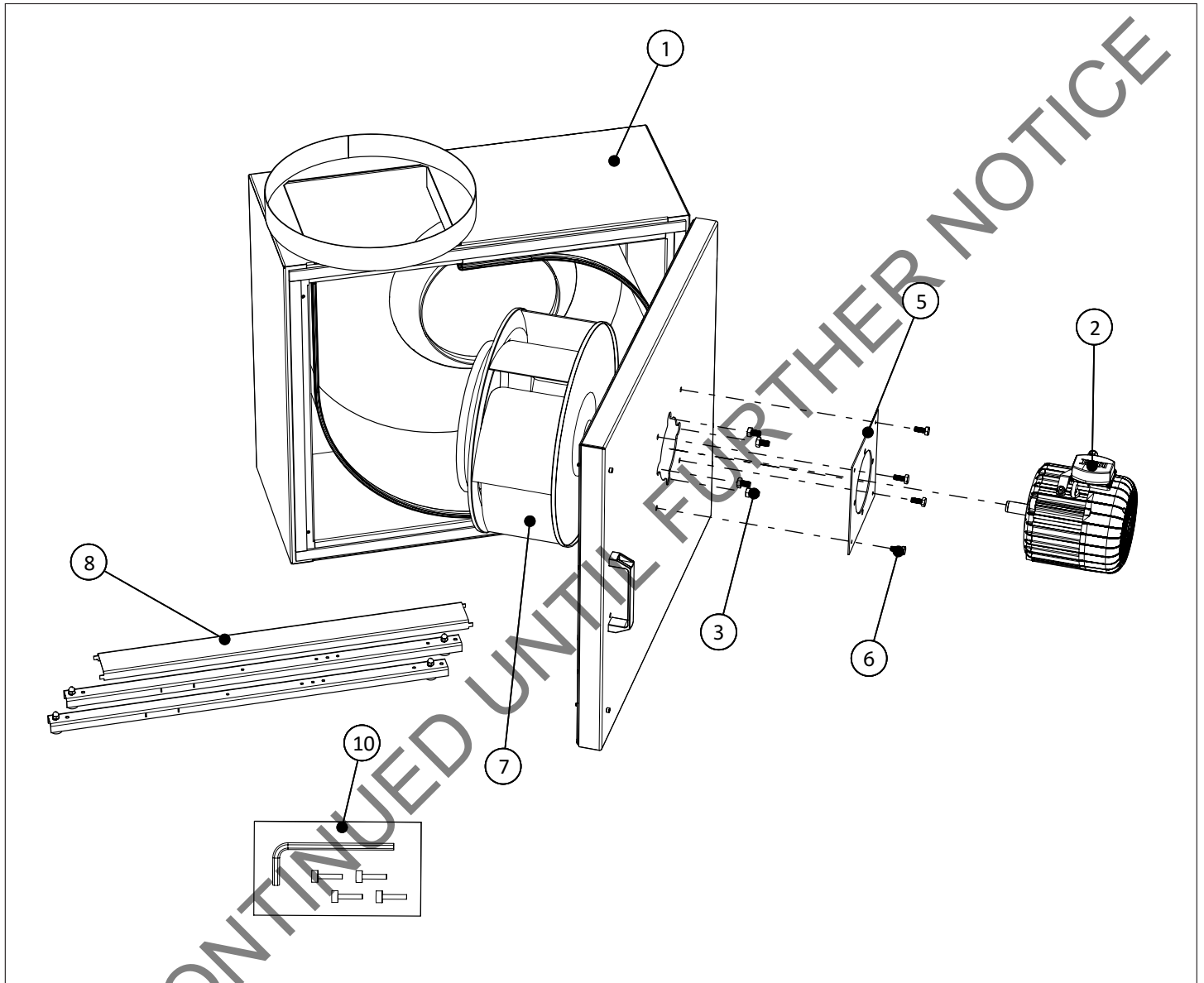

- 1 Housing
- 2 Motor
- 3 Spacer
- 4
- 5 Motor mounting plate
- 6 Bolts
- 7 Impeller
- 8 Support legs
- 9
- 10 Allen key and bolts

7. WARRANTY TERMS – BPV

ENERVEX warrants the BPV Box Power Venter against functional failure due to defects in material and workmanship for a period of two (2) years from date of delivery to the construction site. Functional failure is defined as any failure of the power venter to perform its intended function of exhausting products of combustion. During this period, any BPV Box Power Venter supplied by ENERVEX failing to perform its intended function will be repaired or replaced, at the manufacturer's option, following determination by a factory authorized inspector that a functional failure has occurred.

This warranty is limited to repair or replacement of the product (including, but not limited to, motor and housing) plus shipping cost to the failure location. This warranty does not cover any labor cost for removal or replacement of the defective product nor does this warranty cover any component not furnished by ENERVEX and installed as part of the system.

This warranty is a two-way agreement. ENERVEX promises to supply free replacements as stated, but the user agrees that, except for our obligation to make good on this promise, ENERVEX shall not be responsible for any expense or inconvenience which the user might incur or experience with respect to the product, nor shall ENERVEX be liable for defects, damage or failures, caused by unauthorized alterations, unreasonable use, accident or abuse, including

failure to provide reasonable and necessary maintenance, after the product has been delivered. Some states do not allow the exclusion or limitation of incidental or consequential damages, so the above limitations or exclusions may not apply to you.

ENERVEX assumes no liability for incidental or consequential damages of any kind or for any damages resulting in whole or in part from misuse, improper installation, or inadequate maintenance of the system or any component part thereof. This warranty is in lieu of all other express warranties or guarantees of any kind. All implied warranties, including merchantability and fitness, are limited to the duration of the express warranty contained herein. ENERVEX neither assumes nor does it authorize any other person to assume on its behalf any other liability in connection with the sale of its product.

In addition, we promise the original user that we will replace or repair as we may elect, any parts or parts of the ENERVEX Box Power Venter which are perforated due to corrosion without charge for parts or labor (not including dismantling, installation, freight, etc.) during the first 10 years following the date of installation.

For prompt warranty service, contact the ENERVEX Customer Service Department, 1685 Bluegrass Lakes Parkway, Alpharetta, GA 30004.